



# HIGH PRESSURE HYDRAULIC EQUIPMENT

**CATALOGUE**



GENERAL CATALOGUE		Page
Introduction		2

CYLINDERS	Model	Page
General Features		4
Single Acting Spring Return Cylinders	SM	6
Attachments for SM and D Cylinders	SM and D	10
Aluminium Single Acting Cylinders, Spring Return	SAM	12
Single Acting Hollow Piston Cylinders, Spring Return	SH	16
Aluminium Single Acting Cylinders, Hollow Piston, Spring Return	SAH	18
Single Acting Low Height Cylinders, Load or Spring Return	SP - SMP	22
Single Acting Low Height Cylinders, High Tonnage, Load Return	SPR	24
Single Acting Low Profile Cylinders, Load or Spring Return	SX - SMX	28
Single Acting Low Height Telescopic Cylinders	SLX	30
Single Acting Lock Nut Cylinders, Load Return	STR	32
Aluminium Single Acting Cylinders, Lock Nut, Load Return	SAT	38
Aluminium Single Acting Cylinders, Lock Nut, Stop Ring, Spring Return	SATM	42
Single Acting Pancake Cylinders, Lock Nut/Tilting Saddle, Load Return	STX	46
Single Acting Telescopic Cylinders	SL	48
Single Acting High Tonnage Cylinders, Load Return	SSR	50
Pull Cylinders	T - TE - TD	54
Double Acting Cylinders	D	56
Double Acting High Tonnage Cylinders	DDR	60
Aluminium Double Acting Cylinders	DDA	64
Double Acting Hollow Piston Cylinders	DH	68
Aluminium Double Acting Cylinders, Hollow Piston	DAH	70
Double Acting Production Cylinders	DM - DI	72
Cylinder - Pump Sets	J	76

PUMPS	Model	Page
General Features		78
Hydraulic Single Acting Hand Pumps	W	80
Hydraulic Double Acting Hand Pumps	X	80
Hydraulic Aluminium Hand Pumps	WA	82
Hydraulic Aluminium Hand Pump 2.800 bar	WA	84
Air Hydraulic Pumps 700 bar	Z - ZR	86
Air Hydraulic Pumps 1.000 bar	Z	86
Hydraulic Powerpacks Manual valve	HBM	88
Hydraulic Powerpacks Solenoid valve	HBE	90
HBM and HBE Powerpacks Selection Tables	HBM - HBE	92
Air Driven Hydraulic Pumps	HAZ	94
Petrol Hydraulic Pumps	HAG	95
Accessories for Powerpacks	B - C - D - H - P - R	96
Split-Flow Powerpacks	HFM - HFE	98
Modular Hand Pumps	WI	100
Battery Powered Portable Hydraulic Pump	HAB	101
Air Driven Hydrotest Pumps	HAP	102
Hydrotest Hand Pumps	WAP - WIP	104
Electric Hydrotest Pumps	HEP	106
Torque Wrench Pumps	HAT	108



# INDEX

ACCESSORIES	Model	Page
General Features		110
Hydraulic Hoses	AP - AR	112
Hydraulic Oil	AZ89	113
Hydraulic Couplers	AZ3	114
Flow Control Valves	AZ5	116
Saddles	AZ04 - AZ05	118
Fittings and Manifolds	AZ1	120
Directional Control Valves	AZ8 - AZ9	122
Pressure Gauges	AV - AVD - AT - AY	123

TOOLS	Model	Page
General Features		124
Hydraulic Chain Cutters	CK	126
Hydraulic Cable Cutters	CC	128
Hydraulic Nut Splitters	CN	130
Hydraulic Pullers	FU - FV - FZ	132
Self-Centering Pullers	FA	135
Spread Cylinders	CY	136
Dynamometers & Load Cells	CT - C	138
Lifting Cushions	AA	140
Hydraulic Toe Jacks	AU	141
Flange Spreaders	BS	142
Square Drive Hydraulic Torque Wrenches	LS	144
Low Profile Hydraulic Hexagon Torque Wrenches	LX	148
Portable Hydraulic Punching Heads	PH	152
Hydraulic Crimping Tools	CB - CH - CM	153

AUTOMOTIVE	Model	Page
General Features		156
Bottle Jacks	A - AB	158
High Lift Transmission Jacks	AF	160
Trolley Jacks	B	161
Portable Cranes	DLR	162
Lifting Tables	F	163
Air Service Jacks	HN	164
High Tonnage Air Service Jacks	HL	166
Pipe Benders	VA - VB	168
Presses	EC-EE-EM-EZ	169
Maintenance Set	CA	172

GREEN PAGES	Page
Applications and Special Products	174
Safety Information	180
Cylinder Selection	182
Pump Selection	183
System Assemblies	184
Technical Information	186
Basic Hydraulics	188
Unit Converter	189

MODEL	Page
A	158
AA	140
AB	158
AF	160
AP	112
AR	112
AT	123
AU	141
AV	123
AVD	123
AY	123
AZ04	118
AZ05	118
AZ1	120
AZ3	114
AZ5	116
AZ8	122
AZ89	113
AZ9	122
B	161
BS	142
C	138
CA	172
CB	153
CC	128
CH	153
CK	126
CM	153
CN	130
CT	138
CY	136
D	56
DAH	70
DDA	64
DDR	60
DH	68
DI	72
DLR	162
DM	72
EC	169
EE	169
EM	169
EZ	169
F	163
FA	135
FI	132
FR	132
FT	132

MODEL	Page
FU	132
FV	132
FZ	132
HAB	101
HAG	95
HAP	102
HAT	108
HAZ	94
HBE	90
HBM	88
HEP	106
HFE	98
HFM	98
HL	166
HN	164
J	76
LS	144
LX	148
PH	152
SAH	18
SAM	12
SAT	38
SATM	42
SH	16
SL	48
SLX	30
SM	6
SMP	22
SMX	28
SP	22
SPR	24
SSR	50
STR	32
STX	46
SX	28
T	54
TD	54
TE	54
VA	168
VB	168
W	80
WA	82
WAP	104
WI	100
WIP	104
X	80
Z	86
ZR	86



## Larzep manufactures and markets high pressure hydraulic equipment

Founded in 1940 and since then, we have been making constant improvements, in order to offer you a better and wider service.

Located in Northern Spain, an area with a long experience and traditionally associated with engineering, we have modern facilities and machinery for fast and reliable production.

As the Leading Alternative, we are trustworthy, safe, reliable, quick, efficient and flexible to adapt to each of our customers needs and requirements. We have a worldwide reputation that is supported by an extensive network of Distributors and Technical Service Centres that makes sure we have the support and coverage for our customers worldwide.

### **Actuant**

Larzep is wholly owned by Actuant Corporation, a diversified industrial company serving customers from operations in more than 30 countries.

The Actuant businesses are leaders in a broad array of niche markets including branded hydraulic tools and solutions; specialized products and services for energy markets and highly engineered position and motion control systems.

The Company was founded in 1910 and is headquartered in Menomonee Falls, Wisconsin, USA. Actuant trades on the NYSE under the symbol ATU.

For further information on Actuant and its businesses, visit the Company's website at [www.actuant.com](http://www.actuant.com)





# INTRODUCTION



## The most advanced technology

Our products are specifically designed to cover multiple industrial applications, and to solve in a simple and economical way the problems which can be encountered with the movement of heavy loads. We use the most advanced technology in our Technical Department to make sure customers problems are solved in a timely manner utilizing our special products and tools.

## Quality

A specific solution for each customer, with the best design and best manufacturing techniques and control, we test each product to guarantee its safety and reliability.

This process is supported by the Registered Firm Certificate ER-0404/1995 of UNE-EN ISO 9001 standard and the application of several European and International standards which we apply for each product range. Our Quality Management System is certified since 1995.



## HYDRAULIC CYLINDERS























**LARZEP** cylinders are made of the highest quality materials. Our ranges of products are able to perform all kind of industrial applications such as: lifting, pushing, pulling, bending, holding, etc. The Quality System UNE-EN ISO 9001 since 1995 and the standard ANSI-B30.1 / EN1494 guarantees the design, manufacturing, supply and aftersales service.

All our products are tested individually in order to maximize the quality and the safety of all them.

- ✓ Fully comply with ANSI-B30.1 / EN1494.
- ✓ All units load tested under 125% of the nominal capacity.
- ✓ Mechanical end of stroke gland avoids over travel at full pressure.
- ✓ Cylinder bodies made out of solid high strength alloy steel.
- ✓ Hard chrome plated pistons.
- ✓ Wiper seal reduces contamination and allows longer life.
- ✓ Wear rings for long service life and high absorption of side loads.
- ✓ Hardened grooved saddles as standard, optional tilting saddles improve side load resistance.
- ✓ Heavy cylinders include carrying handles or eye bolts.
- ✓ Female coupling AZ3140 with plastic dust cap included in all cylinders.
- ✓ LARZEP designs and manufactures special cylinders and fixing systems.



# CYLINDERS

Models	Cylinder Type	Capacity Tn (kN)	Stroke mm		Page
<b>SM</b>	Single Acting Spring Return Cylinders Attachments for SM and D cylinders (P.10)	<b>5 - 220</b> (45 - 2.156)	25 - 362		<b>6</b>
<b>SAM</b>	Aluminium Single Acting Cylinders, Spring Return	<b>23 - 200</b> (228 - 1.947)	50 - 300		<b>12</b>
<b>SH</b>	Single Acting Hollow Piston Cylinders, Spring Return	<b>12 - 100</b> (121 - 1.018)	40 - 150		<b>16</b>
<b>SAH</b>	Aluminium Single Acting Cylinders, Hollow Piston, Spring Return	<b>22 - 100</b> (217 - 1.019)	50 - 250		<b>18</b>
<b>SP - SMP</b>	Single Acting Low Height Cylinders, Load or Spring Return	<b>10 - 100</b> (109 - 911)	40 - 150		<b>22</b>
<b>SPR</b>	Single Acting Low Height Cylinders, High Tonnage, Load Return	<b>140 - 1.100</b> (1.379 - 10.910)	50 - 300		<b>24</b>
<b>SX - SMX</b>	Single Acting Low Profile Cylinders, Load or Spring Return	<b>4 - 150</b> (44 - 1.450)	6 - 16		<b>28</b>
<b>SLX</b>	Single Acting Low Height Telescopic Cylinders	<b>4 - 75</b> (43 - 727)	17 - 40		<b>30</b>
<b>STR</b>	Single Acting Lock Nut Cylinders, Load Return	<b>30 - 1.100</b> (303 - 10.905)	50 - 300		<b>32</b>
<b>SAT</b>	Aluminium Single Acting Cylinders, Lock Nut, Load Return	<b>30 - 200</b> (303 - 1.946)	50 - 300		<b>38</b>
<b>SATM</b>	Aluminium Single Acting Cylinders, Lock Nut, Stop Ring, Spring Return	<b>30 - 200</b> (303 - 1.946)	50 - 300		<b>42</b>
<b>STX</b>	Single Acting Pancake Cylinders, Lock Nut Tilting Saddle, Load Return	<b>50 - 1.100</b> (486 - 10.905)	45 - 50		<b>46</b>
<b>SL</b>	Single Acting Telescopic Cylinders	<b>15 - 30</b> (137 - 309)	270 - 600		<b>48</b>
<b>SSR</b>	Single Acting High Tonnage Cylinders, Load Return	<b>140 - 1.100</b> (1.380 - 10.916)	50 - 300		<b>50</b>
<b>T - TE - TD</b>	Pull Cylinders	<b>5 - 50</b> (54 - 483)	140 - 150		<b>54</b>
<b>D</b>	Double Acting Cylinders	<b>10 - 550</b> (109 - 5.519)	50 - 320		<b>56</b>
<b>DDR</b>	Double Acting High Tonnage Cylinders	<b>50 - 1.100</b> (486 - 10.921)	50 - 300		<b>60</b>
<b>DDA</b>	Aluminium Double Acting Cylinders	<b>50 - 200</b> (487 - 1.946)	50 - 300		<b>64</b>
<b>DH</b>	Double Acting Hollow Piston Cylinders	<b>30 - 150</b> (302 - 1.407)	38 - 250		<b>68</b>
<b>DAH</b>	Aluminium Double Acting Cylinders, Hollow Piston	<b>30 - 150</b> (302 - 1.407)	50 - 250		<b>70</b>
<b>DM - DI</b>	Double Acting Production Cylinders	<b>4 - 23</b> (34 - 228)	28 - 260		<b>72</b>
<b>J</b>	Cylinder-Pump Sets	<b>5 - 100</b> (49 - 1.018)	40 - 362		<b>76</b>

## SINGLE ACTING SPRING RETURN CYLINDERS



- ✓ Capacity from 5 to 220 Tn, stroke up to 360 mm.
- ✓ Industrial general purpose cylinders.
- ✓ Strong spring for quick retraction, can be used in all positions.
- ✓ Collar threads, piston end threads and base holes, for accessory mounting.
- ✓ Hard chrome-plated piston with wiper seal to extend cylinder life.
- ✓ Heavy cylinders have carrying handles or eye bolts as standard.
- ✓ Body made of solid steel.
- ✓ Stop ring can withstand full capacity of the cylinder.
- ✓ Guiding bands to improve resistance against side loads.





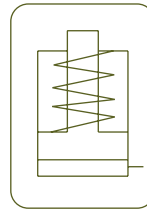

**S/A SPRING RETURN CYLINDERS**



Type	<b>SM</b>
Capacity	5-220 Tn
Stroke	25 - 362 mm
Max. pressure	700 bar

SM CYLINDERS



In case of operation under side loads, Larzep can supply tilting saddles.

**AZ04**  
Optional Tilting Saddles



P.118

**SM & D**  
Special attachments for SM and D models



P.10

**AZ3**  
Coupler 3/8" - 18 NPT included



P.114



Larzep designs and manufactures special cylinders and fixing systems. For further information, please contact our Internal Sales department.

**SAM**  
Lightweight Aluminium Cylinders



P.12

**D**  
Double Acting Cylinders



P.56

**J**  
Cylinder and pump sets



P.76

**Models from 100 to 140 Tn.**

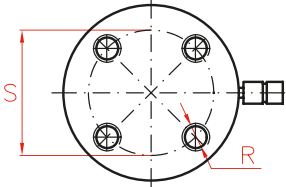

**Models up to 75 Tn.**

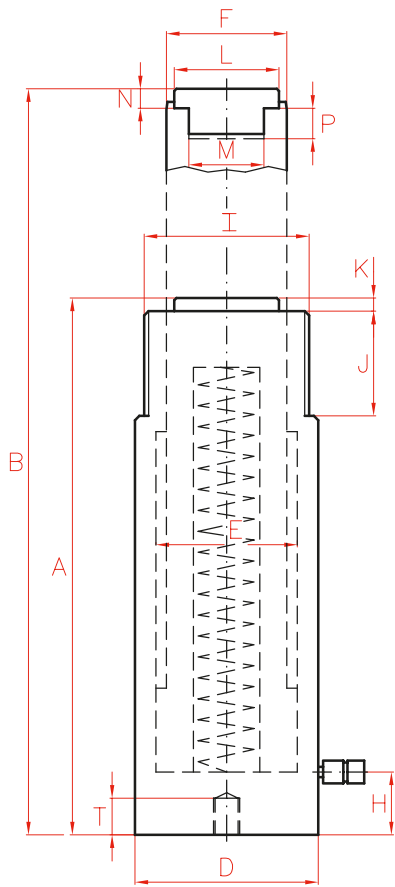
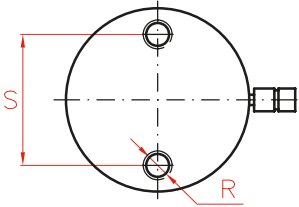

Capacity		Stroke	Model	Oil Cap.	A	B	D	E	F	H	I	
Tn	kN	mm	LARZEP	cm <sup>3</sup>	mm	mm	mm	mm	mm	mm	UN	
5	49	25	SM00502	18	110	135	40	30	25	19	1 1/2"-16	
		76	SM00508	54	168	244	40	30	25	19	1 1/2"-16	
		127	SM00513	90	219	346	40	30	25	19	1 1/2"-16	
		180	SM00518	128	276	456	40	30	25	19	1 1/2"-16	
		232	SM00523	164	328	560	40	30	25	19	1 1/2"-16	
10	109	25	SM01002	40	90	115	60	45	36	20	2 1/4"-14	
		54	SM01005	86	121	175	60	45	36	20	2 1/4"-14	
		105	SM01010	167	172	277	60	45	36	20	2 1/4"-14	
		155	SM01015	247	247	402	60	45	36	20	2 1/4"-14	
		205	SM01020	326	301	506	60	45	36	20	2 1/4"-14	
		257	SM01025	409	352	609	60	45	36	20	2 1/4"-14	
		307	SM01030	489	402	709	60	45	36	20	2 1/4"-14	
355	SM01035	565	454	809	60	45	36	20	2 1/4"-14			
15	163	25	SM01502	60	127	152	75	55	45	20	2 3/4"-16	
		54	SM01505	129	155	209	75	55	45	20	2 3/4"-16	
		105	SM01510	250	205	310	75	55	45	20	2 3/4"-16	
		155	SM01515	369	275	430	75	55	45	20	2 3/4"-16	
		205	SM01520	487	327	532	75	55	45	20	2 3/4"-16	
		257	SM01525	611	379	636	75	55	45	20	2 3/4"-16	
		307	SM01530	730	426	733	75	55	45	20	2 3/4"-16	
355	SM01535	844	477	832	75	55	45	20	2 3/4"-16			
23	228	25	SM02302	83	140	165	85	65	56	25	3 5/16"-12	
		51	SM02305	170	166	217	85	65	56	25	3 5/16"-12	
		102	SM02310	339	217	319	85	65	56	25	3 5/16"-12	
		159	SM02315	528	277	436	85	65	56	25	3 5/16"-12	
		210	SM02321	697	327	537	85	65	56	25	3 5/16"-12	
		261	SM02326	866	379	640	85	65	56	25	3 5/16"-12	
		310	SM02331	1.029	430	740	85	65	56	25	3 5/16"-12	
		362	SM02336	1.201	480	842	85	65	56	25	3 5/16"-12	
30	303	60	SM03006	265	165	225	100	75	60	30	3 7/8"-12	
		150	SM03015	663	270	420	100	75	60	30	3 7/8"-12	
		210	SM03021	928	340	550	100	75	60	30	3 7/8"-12	
50	487	60	SM05006	426	176	236	127	95	80	35	5"-12	
		102	SM05010	723	227	329	127	95	80	35	5"-12	
		160	SM05016	1.134	285	445	127	95	80	35	5"-12	
		200	SM05020	1.418	325	525	127	95	80	35	5"-12	
		250	SM05025	1.772	376	626	127	95	80	35	5"-12	
339	SM05034	2.402	465	804	127	95	80	35	5"-12			
75	713	160	SM07516	1.661	285	445	150	115	90	35	5 3/4"-12	
		330	SM07533	3.426	495	825	150	115	90	35	5 3/4"-12	
100	911	60	SM10006	797	180	240	177	130	110	40	6 7/8"-12	
		150	SM10015	1.991	300	450	177	130	110	40	6 7/8"-12	
		260	SM10026	3.451	449	709	177	130	110	40	6 7/8"-12	
140	1.380	60	SM14006	1.206	190	250	216	160	140	40	8 1/2"-12	
		150	SM14015	3.015	320	470	216	160	140	40	8 1/2"-12	
		260	SM14026	5.226	470	730	216	160	140	40	8 1/2"-12	
220	2.156	150	SM22015	4.710	340	490	250	200	160	40	-	



\* SM01002 and SM01502 models are not provided with removable saddles.



Always read the safety instructions.

	J	K	L	M	N	P	R	S	T	Area	Weight	Model	With tilting saddle	
	mm	mm	mm	UN	mm	mm	UN	mm	mm	cm <sup>2</sup>	kg	LARZEP	A	Model
	28	6	25	3/4"-16	6	14	1/4"-20	25	14	7	1,0	SM00502	-	-
	28	6	25	3/4"-16	6	14	1/4"-20	25	14	7	1,5	SM00508	-	-
	28	6	25	3/4"-16	6	14	1/4"-20	25	14	7	1,9	SM00513	-	-
	28	6	25	3/4"-16	6	14	1/4"-20	25	14	7	2,4	SM00518	-	-
	28	6	25	3/4"-16	6	14	1/4"-20	25	14	7	2,8	SM00523	-	-
	32	6	30	*	*	*	5/16"-18	39	12	16	1,8	SM01002	*	*
	32	6	28	1"-8	10	19	5/16"-18	39	12	16	2,4	SM01005	140	AZ0420
	32	6	28	1"-8	10	19	5/16"-18	39	12	16	3,3	SM01010	191	AZ0420
	32	6	28	1"-8	10	19	5/16"-18	39	12	16	4,7	SM01015	266	AZ0420
	32	6	28	1"-8	10	19	5/16"-18	39	12	16	5,7	SM01020	320	AZ0420
	32	6	28	1"-8	10	19	5/16"-18	39	12	16	6,6	SM01025	371	AZ0420
	32	6	28	1"-8	10	19	5/16"-18	39	12	16	7,4	SM01030	421	AZ0420
	32	6	28	1"-8	10	19	5/16"-18	39	12	16	8,4	SM01035	473	AZ0420
	32	8	35	*	*	*	3/8"-16	47	12	24	4,2	SM01502	*	*
	32	8	35	1"-8	8	25	3/8"-16	47	12	24	5,0	SM01505	176	AZ0423
	32	8	35	1"-8	8	25	3/8"-16	47	12	24	6,4	SM01510	226	AZ0423
	32	8	35	1"-8	8	25	3/8"-16	47	12	24	8,5	SM01515	296	AZ0423
	32	8	35	1"-8	8	25	3/8"-16	47	12	24	10,0	SM01520	348	AZ0423
	32	8	35	1"-8	8	25	3/8"-16	47	12	24	11,5	SM01525	400	AZ0423
	32	8	35	1"-8	8	25	3/8"-16	47	12	24	12,8	SM01530	447	AZ0423
	32	8	35	1"-8	8	25	3/8"-16	47	12	24	14,2	SM01535	498	AZ0423
	45	10	45	1 1/2"-16	10	25	1/2"-13	58	19	33	6,0	SM02302	158	AZ0421
	45	10	45	1 1/2"-16	10	25	1/2"-13	58	19	33	7,0	SM02305	184	AZ0421
	45	10	45	1 1/2"-16	10	25	1/2"-13	58	19	33	8,9	SM02310	235	AZ0421
	45	10	45	1 1/2"-16	10	25	1/2"-13	58	19	33	11,2	SM02315	295	AZ0421
	45	10	45	1 1/2"-16	10	25	1/2"-13	58	19	33	13,0	SM02321	345	AZ0421
	45	10	45	1 1/2"-16	10	25	1/2"-13	58	19	33	15,0	SM02326	397	AZ0421
	45	10	45	1 1/2"-16	10	25	1/2"-13	58	19	33	16,9	SM02331	448	AZ0421
	45	10	45	1 1/2"-16	10	25	1/2"-13	58	19	33	18,8	SM02336	498	AZ0421
	48	10	45	1 1/2"-16	10	25	1/2"-13	66	19	44	9,3	SM03006	183	AZ0421
	48	10	45	1 1/2"-16	10	25	1/2"-13	66	19	44	14,6	SM03015	288	AZ0421
	48	10	45	1 1/2"-16	10	25	1/2"-13	66	19	44	18,2	SM03021	358	AZ0421
	55	5	61	-	12	-	1/2"-13	95	19	71	16,4	SM05006	203	AZ0402
	55	5	61	-	12	-	1/2"-13	95	19	71	20,7	SM05010	254	AZ0402
	55	5	61	-	12	-	1/2"-13	95	19	71	25,5	SM05016	312	AZ0402
	55	5	61	-	12	-	1/2"-13	95	19	71	29,0	SM05020	352	AZ0402
	55	5	61	-	12	-	1/2"-13	95	19	71	33,1	SM05025	403	AZ0402
	55	5	61	-	12	-	1/2"-13	95	19	71	40,4	SM05034	492	AZ0402
	55	5	61	-	12	-	3/4"-10	115	19	104	32,0	SM07516	312	AZ0402
	55	5	61	-	12	-	3/4"-10	115	19	104	54,0	SM07533	522	AZ0402
	55	5	88	-	14	-	3/4"-10	139	25	133	32,0	SM10006	213	AZ0404
	55	5	88	-	14	-	3/4"-10	139	25	133	53,0	SM10015	333	AZ0404
	55	5	88	-	14	-	3/4"-10	139	25	133	78,5	SM10026	482	AZ0404
	55	5	88	-	15	-	3/4"-10	165	25	201	52,0	SM14006	222	AZ0404
	55	5	88	-	15	-	3/4"-10	165	25	201	85,7	SM14015	352	AZ0404
	55	5	88	-	15	-	3/4"-10	165	25	201	124,5	SM14026	502	AZ0404
	-	5	111	-	15	-	-	-	-	314	116,5	SM22015	377	AZ0405

## ATTACHMENTS FOR SM AND D MODELS

### Base Plate

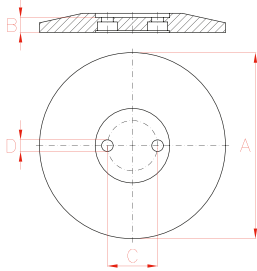

Capacity (Tn)		Model	A	B	C	D	Weight
SM	D	LARZEP	mm	mm	mm	mm	kg
5	-	SM005P	150	15	25	7,0	2,2
10	10	SM010P	180	15	39	8,5	2,7
15	-	SM015P	180	15	47	10,0	2,7
23	20	SM023P	215	17	58	13,5	4,9
30	30	SM030P	215	17	66	13,5	4,9
50	50	SM050P	305	22	95	13,5	13,1
75	-	SM075P	350	32	115	21,0	25,6
100	100	SM100P	400	40	139	21 (4)	29,3

### Mounting Block

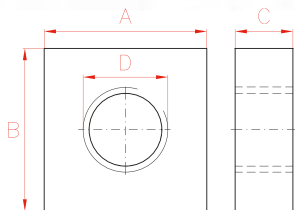

Capacity (Tn)		Model	A	B	C	D
SM	D	LARZEP	mm	mm	mm	UN
5	-	SM005B	76	90	25	1 1/2"- 16
10	10	SM010B	90	114	30	2 1/4"- 14
15	-	SM015B	100	114	30	2 3/4"- 16
23	-	SM023B	127	127	45	3 5/16"- 12
30	30	SM030B	135	135	45	3 7/8"- 12
50	50	SM050B	200	200	55	5"-12
100	100	SM100B	330	330	55	6 7/8"-12

### Collar Toe

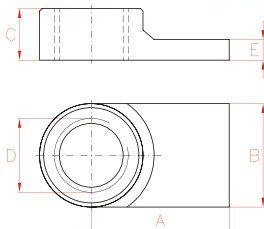

### WARNING

When using this accessory do not exceed 350 bar.

Capacity (Tn)		Model	A	B	C	D	E
SM	D	LARZEP	mm	mm	mm	UN	mm
5	-	SM005U	54	31	25	1 1/2"- 16	11
10	10	SM010U	79	60	37	2 1/4"- 14	12
23	-	SM023U	105	80	40	3 5/16"- 12	20





Clevis Eye Body

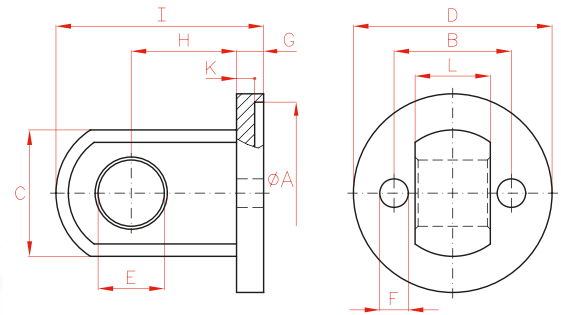

Capacity (Tn)		Model	A	B	C	D	E	F	G	H	I	K	L
SM	D	LARZEP	mm	mm	mm	mm	mm	mm	mm	mm	mm	mm	mm
5	-	SM005RB	41	25	28	46	16	8	9	25	50	6	14
10	10	SM010RB	61	39	42	66	22	10	9	35	69	6	25
15	-	SM015RB	76	47	42	82	22	11	9	35	69	6	25
23	20	SM023RB	86	58	57	95	31	14	12	41	84	7	38

Clevis Eye Piston

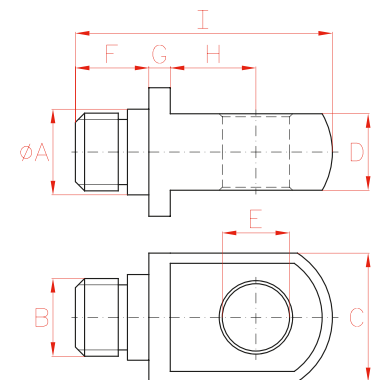

Capacity (Tn)		Model	A	B	C	D	E	F	G	H	I
SM	D	LARZEP	mm	UN	mm	mm	mm	mm	mm	mm	mm
5	-	SM005RP	25	3/4"-16	28	14	16	15	5	19	55
10	10-20	SM010-15RP	28	1"-8	42	25	22	24	7	28	84
23	30	SM023RP	45	1 1/2"-16	57	38	31	27	8	35	101

**ALUMINIUM SINGLE ACTING CYLINDERS, SPRING RETURN**

- ✓ Lightweight, general purpose cylinders from 23 to 200 Tn, stroke up to 300 mm.
- ✓ Made out of high strength aluminium alloy.
- ✓ Solid piston, spring return.
- ✓ All aluminium parts are treated to improve resistance and extend working life.
- ✓ 40% weight reduction when compared with steel equivalent.
- ✓ Fitted with steel base plate and saddle for wear resistance.
- ✓ Not suitable for high cycle applications.

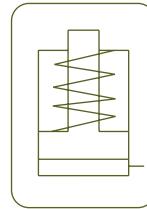

The body, stop ring and piston of the cylinder are hard anodized to strengthen the working area and extend its working life.

The weight reduction makes them especially suitable for use in sites of difficult access.

It is highly recommended to place the cylinder on a flat area in order to avoid any damage to the base.



Larzep designs and manufactures special special aluminium cylinders. For further information, please contact our Internal Sales department.

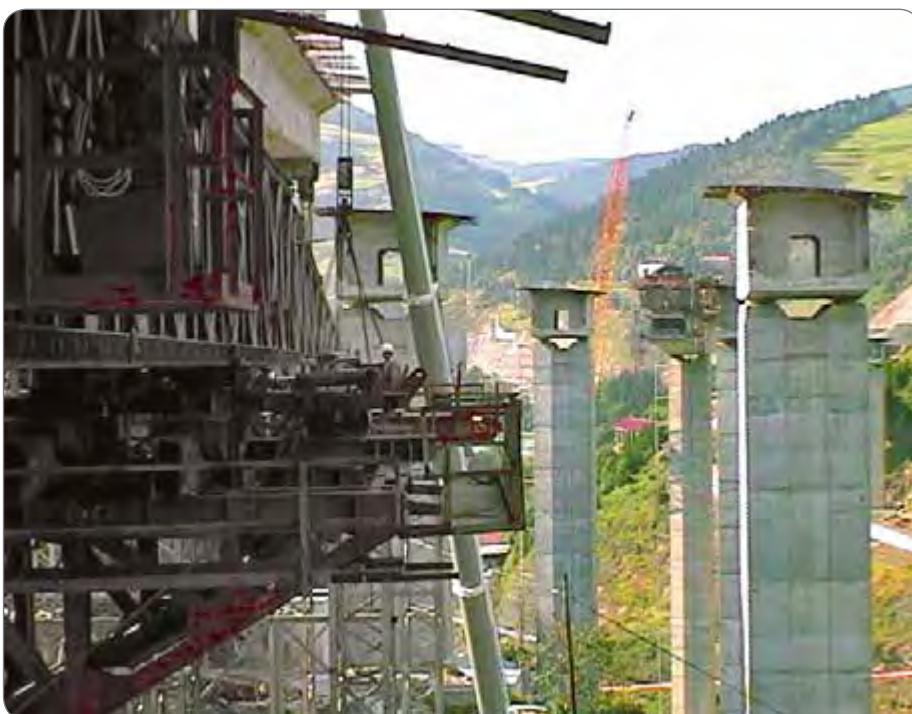

**S/A ALUMINIUM CYLINDERS**



Type	<b>SAM</b>
Capacity	23 - 200 Tn
Stroke	50 - 300 mm
Max. pressure	700 bar

SAM CYLINDERS

**SAH**  
Lightweight Aluminium  
Hollow Piston Cylinders



P.18

**SAT**  
Aluminium Single Acting Cylinders  
with Lock Nut



P.38

**DDA**  
Double Acting Aluminium Cylinders



P.64

**WA**  
Aluminium Hand Pumps



P.82

**HBM/HBE**  
Powerpack



P.88

**Z12107**  
Air Hydraulic Pump



P.86

**W**  
Single Acting Hand Pumps



P.80

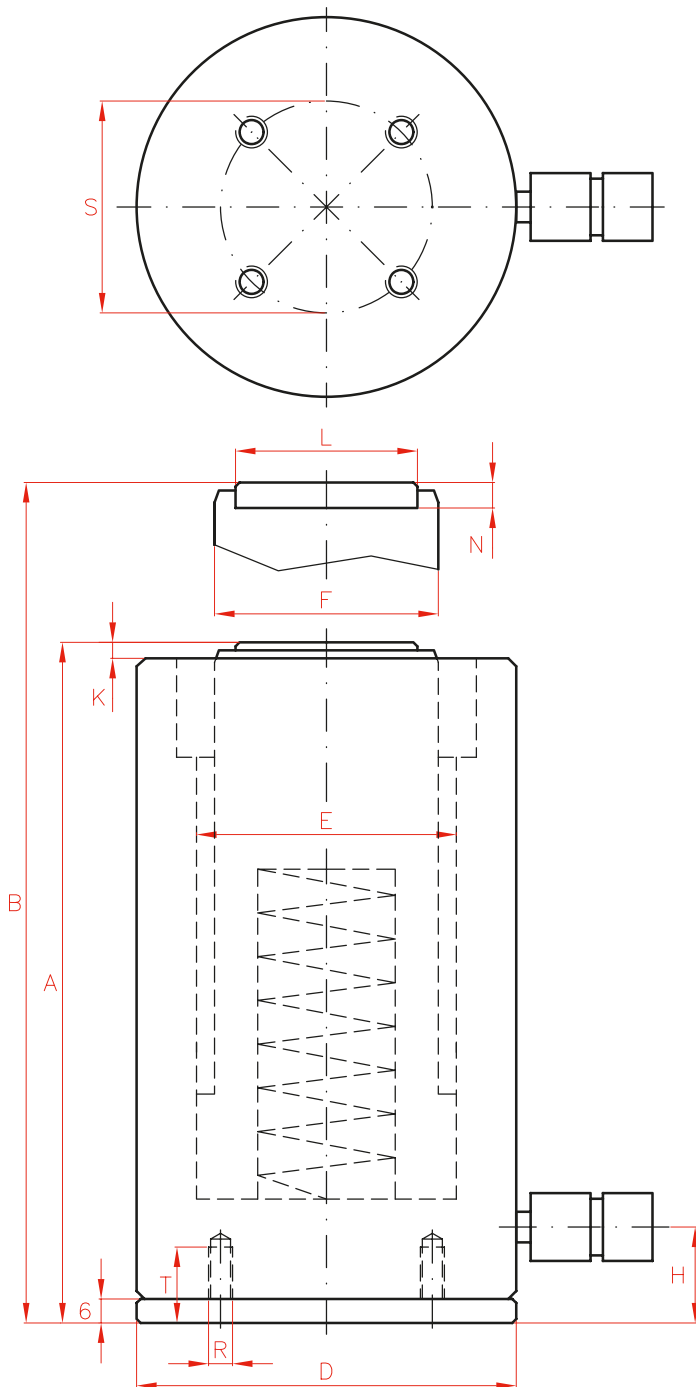

Capacity		Stroke	Model	Oil Cap.	A	
Tn	kN	mm	LARZEP	cm <sup>3</sup>	mm	
23	228	50	SAM02305	166	156	
		100	SAM02310	332	206	
		150	SAM02315	497	256	
		200	SAM02320	663	306	
		250	SAM02325	830	356	
		300	SAM02330	995	406	
30	303	50	SAM03005	221	172	
		100	SAM03010	442	222	
		150	SAM03015	663	272	
		200	SAM03020	883	322	
		250	SAM03025	1.104	372	
		300	SAM03030	1.325	422	
50	487	50	SAM05005	354	180	
		100	SAM05010	709	230	
		150	SAM05015	1.063	280	
		200	SAM05020	1.417	330	
		250	SAM05025	1.772	380	
		300	SAM05030	2.126	430	
100	911	50	SAM10005	663	210	
		100	SAM10010	1.326	260	
		150	SAM10015	1.989	310	
		200	SAM10020	2.652	360	
		250	SAM10025	3.315	410	
		300	SAM10030	3.982	460	
140	1.380	50	SAM14005	1.005	225	
		100	SAM14010	2.010	275	
		150	SAM14015	3.016	325	
		200	SAM14020	4.021	375	
		250	SAM14025	5.026	425	
200	1.947	50	SAM20005	1.417	234	
		100	SAM20010	2.835	284	
		150	SAM20015	4.253	334	





OPTIONAL TILTING SADDLES

Model	L	N	Weight
LARZEP	mm	mm	kg
AZ0401	45	36	0,4
AZ0402	61	39	0,8
AZ0404	88	47	2,2
AZ0405	111	52	4,0

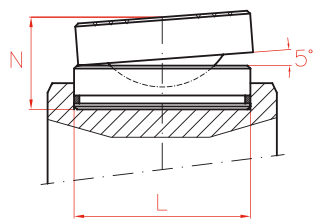

P.118

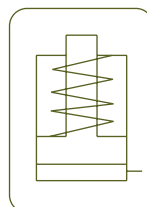

Type **SAM**

Capacity **23 - 200 Tn**

Stroke **50 - 300 mm**

Max. pressure **700 bar**

	B	D	E	F	H	K	L	N	R	S	T	Area	Weight	Model	With tilting saddle	
	mm	mm	mm	mm	mm	mm	mm	mm		mm	mm	cm <sup>2</sup>	kg	LARZEP	A	Model
	206	95	65	56	24	4	45	11	M6	80	19	33	3,6	<b>SAM02305</b>	181	AZ0401
	306	95	65	56	24	4	45	11	M6	80	19	33	4,3	<b>SAM02310</b>	231	AZ0401
	406	95	65	56	24	4	45	11	M6	80	19	33	5,0	<b>SAM02315</b>	281	AZ0401
	506	95	65	56	24	4	45	11	M6	80	19	33	5,7	<b>SAM02320</b>	331	AZ0401
	606	95	65	56	24	4	45	11	M6	80	19	33	6,4	<b>SAM02325</b>	381	AZ0401
	706	95	65	56	24	4	45	11	M6	80	19	33	7,1	<b>SAM02330</b>	431	AZ0401
	222	105	75	60	24	6	45	11	M6	85	19	44	4,8	<b>SAM03005</b>	197	AZ0401
	322	105	75	60	24	6	45	11	M6	85	19	44	5,4	<b>SAM03010</b>	247	AZ0401
	422	105	75	60	24	6	45	11	M6	85	19	44	6,4	<b>SAM03015</b>	297	AZ0401
	522	105	75	60	24	6	45	11	M6	85	19	44	7,4	<b>SAM03020</b>	347	AZ0401
	622	105	75	60	24	6	45	11	M6	85	19	44	8,4	<b>SAM03025</b>	397	AZ0401
	722	105	75	60	24	6	45	11	M6	85	19	44	9,3	<b>SAM03030</b>	447	AZ0401
	230	135	95	80	26	7	61	12	M6	115	19	71	8,0	<b>SAM05005</b>	207	AZ0402
	330	135	95	80	26	7	61	12	M6	115	19	71	9,5	<b>SAM05010</b>	257	AZ0402
	430	135	95	80	26	7	61	12	M6	115	19	71	11,0	<b>SAM05015</b>	307	AZ0402
	530	135	95	80	26	7	61	12	M6	115	19	71	11,5	<b>SAM05020</b>	357	AZ0402
	630	135	95	80	26	7	61	12	M6	115	19	71	13,0	<b>SAM05025</b>	407	AZ0402
	730	135	95	80	26	7	61	12	M6	115	19	71	14,5	<b>SAM05030</b>	457	AZ0402
	260	180	130	110	32	5	88	14	M6	160	19	133	16,0	<b>SAM10005</b>	243	AZ0404
	360	180	130	110	32	5	88	14	M6	160	19	133	19,0	<b>SAM10010</b>	293	AZ0404
	460	180	130	110	32	5	88	14	M6	160	19	133	22,0	<b>SAM10015</b>	343	AZ0404
	560	180	130	110	32	5	88	14	M6	160	19	133	25,0	<b>SAM10020</b>	393	AZ0404
	660	180	130	110	32	5	88	14	M6	160	19	133	28,0	<b>SAM10025</b>	443	AZ0404
	760	180	130	110	32	5	88	14	M6	160	19	133	31,0	<b>SAM10030</b>	493	AZ0404
	275	225	160	140	43	6	88	14	M6	200	19	201	24,0	<b>SAM14005</b>	258	AZ0404
	375	225	160	140	43	6	88	14	M6	200	19	201	29,0	<b>SAM14010</b>	308	AZ0404
	475	225	160	140	43	6	88	14	M6	200	19	201	34,0	<b>SAM14015</b>	358	AZ0404
	575	225	160	140	43	6	88	14	M6	200	19	201	39,0	<b>SAM14020</b>	408	AZ0404
	675	225	160	140	43	6	88	14	M6	200	19	201	44,0	<b>SAM14025</b>	458	AZ0404
	284	265	190	140	51	6	111	15	M6	225	19	284	31,0	<b>SAM20005</b>	271	AZ0405
	384	265	190	140	51	6	111	15	M6	225	19	284	38,0	<b>SAM20010</b>	321	AZ0405
	484	265	190	140	51	6	111	15	M6	225	19	284	45,0	<b>SAM20015</b>	371	AZ0405

**SINGLE ACTING HOLLOW PISTON CYLINDERS, SPRING RETURN**



- ✓ Capacity from 12 to 100 Tn, stroke up to 150 mm.
  - ✓ Spring return, hollow piston.
  - ✓ For push and pull applications: Tensioning cables and bolts, pulling sleeves and bearings.
  - ✓ Body and saddle black nitrided to improve corrosion and wear resistance, except 12 Tn models.
  - ✓ Hollow hard chrome-plated piston.
  - ✓ Collar threads, piston end thread and base holes for easy fixing.
  - ✓ Interchangeable with our complete puller range.
  - ✓ Hollow plain saddle as standard.
- Optional solid or threaded saddles available. Page 118.
- ✓ Hollow cylinders also available in double acting DH and aluminium single and double acting SAH and DAH.

Capacity		Stroke	Model	Oil Cap.	A	B	C	
Tn	kN	mm	LARZEP	cm <sup>3</sup>	mm	mm	mm	
12	121	40	SH01204	70	124	164	21	
		76	SH01208	134	176	252	21	
		150	SH01215	264	300	450	21	
22	217	50	SH02205	158	165	215	27	
		76	SH02208	240	203	279	27	
		150	SH02215	474	318	468	27	
30	302	64	SH03006	281	197	261	34	
		150	SH03015	660	322	472	34	
60	578	76	SH06008	640	223	299	56	
		153	SH06015	1.288	315	468	56	
100	1.019	80	SH10008	1.187	282	362	81	
		150	SH10015	2.225	367	517	81	



**HOLLOW PISTON CYLINDERS**



Type	<b>SH</b>
Capacity	12 - 100 Tn
Stroke	40 - 150 mm
Max. pressure	700 bar

**SAH**  
Lightweight Aluminium  
Hollow Piston Cylinders



P.18

**DH**  
Double Acting Hollow Piston Cylinders



P.68

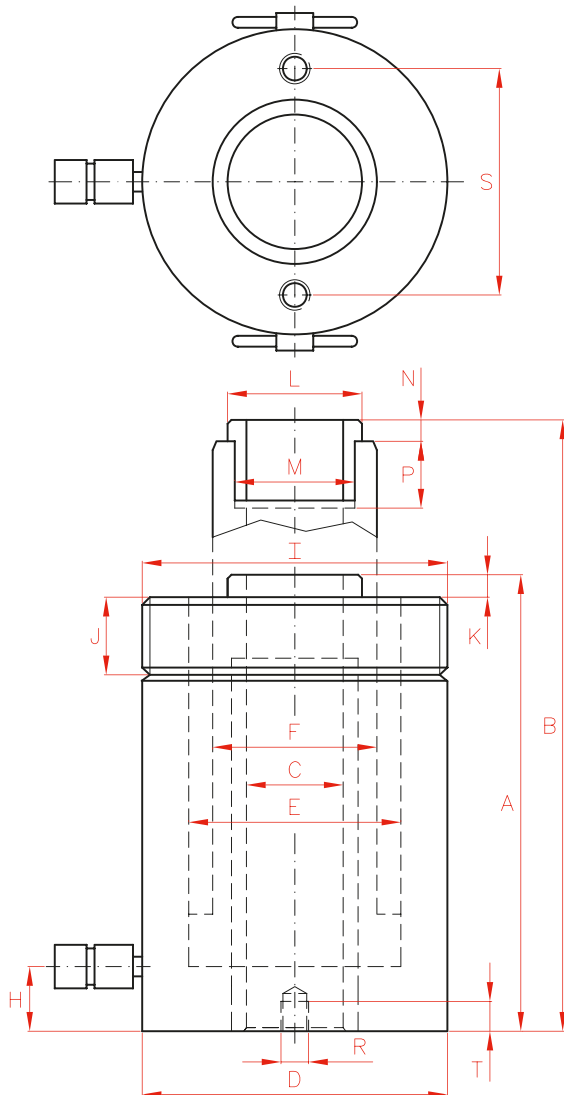
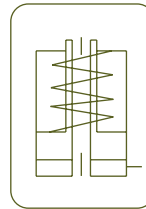

	D	E	F	H	I	J	K	L	M	N	P	R	S	T	Area	Weight	Model
	mm	mm	mm	mm	UN	mm	mm	mm	UN	mm	mm	UN	mm	mm	cm <sup>2</sup>	kg	LARZEP
	75	55	40	19	2 3/4"-16	30	3	34	M28*1,5	7	18	5/16"-18	51	12	18	3,4	<b>SH01204</b>
	75	55	40	19	2 3/4"-16	30	3	34	M28*1,5	7	18	5/16"-18	51	12	18	4,6	<b>SH01208</b>
	75	55	40	19	2 3/4"-16	30	3	34	M28*1,5	7	18	5/16"-18	51	12	18	7,6	<b>SH01215</b>
	105	75	56	23	3 7/8"-12	38	3	48	1 9/16"-16	8	20	3/8"-16	83	15	32	8,6	<b>SH02205</b>
	105	75	56	23	3 7/8"-12	38	3	48	1 9/16"-16	8	20	3/8"-16	83	15	32	11,5	<b>SH02208</b>
	105	75	56	23	3 7/8"-12	38	3	48	1 9/16"-16	8	20	3/8"-16	83	15	32	16,4	<b>SH02215</b>
	120	90	68	26	4 1/2"-12	42	4	55	1 13/16"-16	9	22	3/8"-16	92	17	44	13,2	<b>SH03006</b>
	120	90	68	26	4 1/2"-12	42	4	55	1 13/16"-16	9	22	3/8"-16	92	17	44	18,5	<b>SH03015</b>
	160	125	95	31	6 1/4"-12	48	4	80	2 3/4"-16	12	22	1/2"-13	130	14	84	26,0	<b>SH06008</b>
	160	125	95	31	6 1/4"-12	48	4	80	2 3/4"-16	12	22	1/2"-13	130	14	84	38,0	<b>SH06015</b>
	213	170	130	37	8 3/8"-12	60	5	116	4"-16	13	25	5/8"-11	178	19	148	58,0	<b>SH10008</b>
	213	170	130	37	8 3/8"-12	60	5	116	4"-16	13	25	5/8"-11	178	19	148	79,0	<b>SH10015</b>

**ALUMINIUM SINGLE ACTING CYLINDERS, HOLLOW PISTON, SPRING RETURN**

- ✓ Lightweight hollow cylinders from 22 to 100 Tn and up to 250 mm stroke.
- ✓ Made out of high strength aluminium alloy.
- ✓ Hollow piston, spring return.
- ✓ All aluminium parts are treated to improve resistance and extend working life.
- ✓ Fitted with steel base plate and saddle for wear resistance.
- ✓ 40% weight reduction when compared with steel equivalent.
- ✓ Hollow plain saddle as standard.
- ✓ Not suitable for high cycle applications.



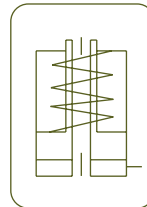

Larzep designs and manufactures special aluminium cylinders and fixing system upon request.

**HOLLOW PISTON ALUM. CYLINDERS**



Type	<b>SAH</b>
Capacity	22 - 100 Tn
Stroke	50 - 250 mm
Max. pressure	700 bar

SAH CYLINDERS

**AZ04 & AZ05**  
Optional Saddles available  
Plain, threaded or solid



P.118

**W**  
Single Acting Hand Pumps



P.80

**DAH**  
Aluminium Double Acting  
Hollow Piston Cylinders



P.70

**WA**  
Aluminium Hand Pumps



P.82



**HBM / HBE**  
Powerpack



P.88

**Z12107**  
Air Hydraulic Pump



P.86

**W**  
Single Acting Hand Pumps



P.80

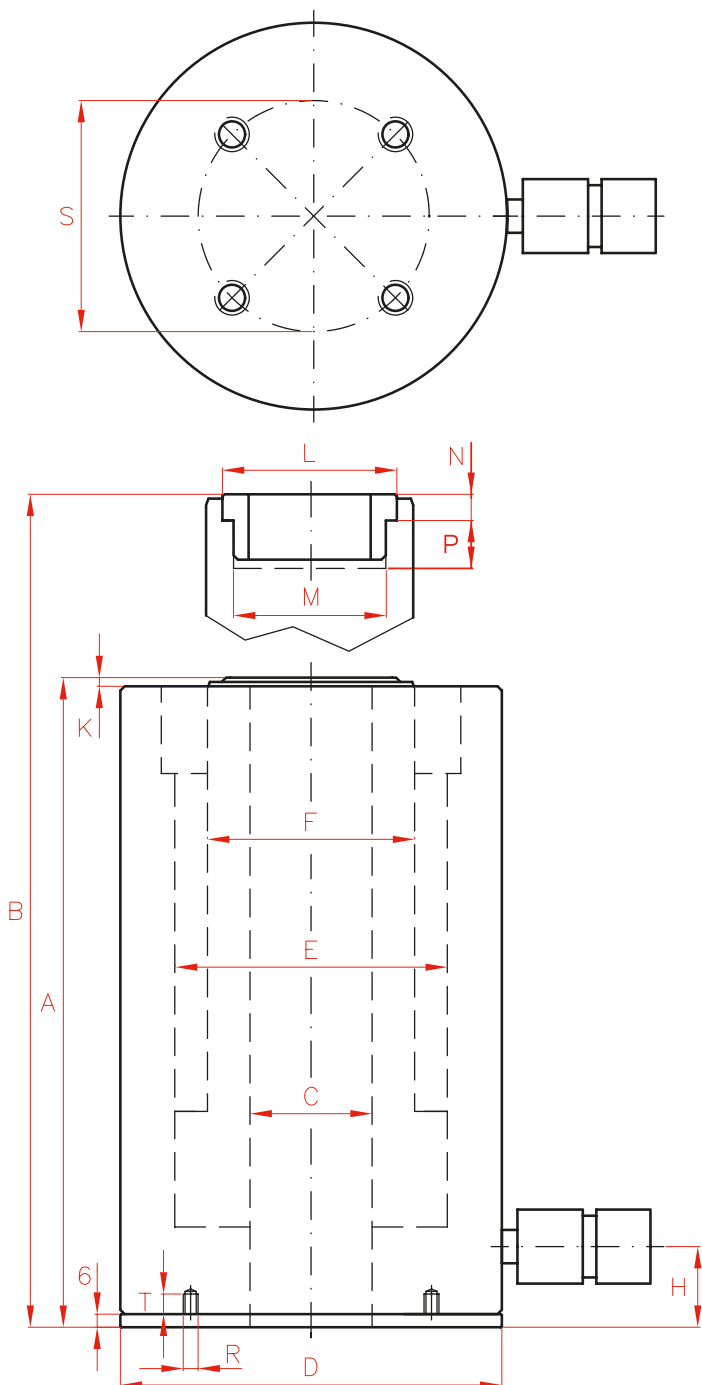

Capacity		Stroke	Model	Oil Cap.	A	
Tn	kN	mm	LARZEP	cm <sup>3</sup>	mm	
22	217	50	SAH02205	158	183	
		100	SAH02210	316	253	
		150	SAH02215	474	323	
		200	SAH02220	632	383	
		250	SAH02225	790	448	
30	302	50	SAH03005	220	210	
		100	SAH03010	440	278	
		150	SAH03015	660	350	
		200	SAH03020	880	410	
		250	SAH03025	1.100	475	
60	578	50	SAH06005	421	243	
		100	SAH06010	842	298	
		150	SAH06015	1.263	363	
		200	SAH06020	1.684	428	
		250	SAH06025	2.105	493	
100	1.018	50	SAH10005	742	260	
		100	SAH10010	1.484	327	
		150	SAH10015	2.226	397	
		200	SAH10020	3.968	462	
		250	SAH10025	3.710	532	



**AZ04 & AZ05**

Optional Saddles available  
Plain, threaded or solid



P.118

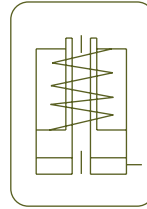

**HOLLOW PISTON ALUM. CYLINDERS**



Type

**SAH**

Capacity

22 - 100 Tn

Stroke

50 - 250 mm

Max. pressure

700 bar

SAH CYLINDERS

**OPTIONAL THREADED SADDLES**

Cylinder Model	Model	C	L	M	N
LARZEP	LARZEP	UN	mm	UN	mm
SAH022	<b>AZ0552</b>	1"-8	48	1 9/16"-16	8
SAH030	<b>AZ0553</b>	1 1/4"-7	55	1 13/16"-16	9
SAH060	<b>AZ0556</b>	1 5/8"-5 1/2	80	2 3/4"-16	12
SAH100	<b>AZ0560</b>	2 1/2"-8	116	4"-16	13

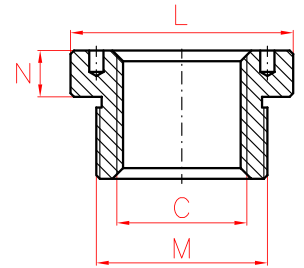

P.118

	B	C	D	E	F	H	K	L	M	N	P	R	S	T	Area	Weight	Model
	mm	mm	mm	mm	mm	mm	mm	mm	UN	mm	mm		mm	mm	cm <sup>2</sup>	kg	LARZEP
	233	27	100	75	56	26	3	48	1 9/16"-16	8	20	M6	85	19	32	4,5	<b>SAH02205</b>
	353	27	100	75	56	26	3	48	1 9/16"-16	8	20	M6	85	19	32	5,8	<b>SAH02210</b>
	473	27	100	75	56	26	3	48	1 9/16"-16	8	20	M6	85	19	32	7,0	<b>SAH02215</b>
	587	27	100	75	56	26	3	48	1 9/16"-16	8	20	M6	85	19	32	8,0	<b>SAH02220</b>
	698	27	100	75	56	26	3	48	1 9/16"-16	8	20	M6	85	19	32	8,8	<b>SAH02225</b>
	260	33	130	90	68	32	4	55	1 11/13"-16	9	22	M6	110	19	44	7,5	<b>SAH03005</b>
	378	33	130	90	68	32	4	55	1 11/13"-16	9	22	M6	110	19	44	10,0	<b>SAH03010</b>
	500	33	130	90	68	32	4	55	1 11/13"-16	9	22	M6	110	19	44	11,5	<b>SAH03015</b>
	610	33	130	90	68	32	4	55	1 11/13"-16	9	22	M6	110	19	44	13,0	<b>SAH03020</b>
	725	33	130	90	68	32	4	55	1 11/13"-16	9	22	M6	110	19	44	14,6	<b>SAH03025</b>
	293	56	175	125	95	37	4	80	2 3/4"-16	12	22	M6	155	19	84	16,3	<b>SAH06005</b>
	398	56	175	125	95	37	4	80	2 3/4"-16	12	22	M6	155	19	84	19,5	<b>SAH06010</b>
	513	56	175	125	95	37	4	80	2 3/4"-16	12	22	M6	155	19	84	23,4	<b>SAH06015</b>
	628	56	175	125	95	37	4	80	2 3/4"-16	12	22	M6	155	19	84	26,0	<b>SAH06020</b>
	743	56	175	125	95	37	4	80	2 3/4"-16	12	22	M6	155	19	84	32,0	<b>SAH06025</b>
	310	81	235	170	130	40	6	116	4"-16	13	25	M6	215	19	148	31,0	<b>SAH10005</b>
	427	81	235	170	130	40	6	116	4"-16	13	25	M6	215	19	148	38,0	<b>SAH10010</b>
	547	81	235	170	130	40	6	116	4"-16	13	25	M6	215	19	148	45,0	<b>SAH10015</b>
	662	81	235	170	130	40	6	116	4"-16	13	25	M6	215	19	148	53,0	<b>SAH10020</b>
	782	81	235	170	130	40	6	116	4"-16	13	25	M6	215	19	148	61,0	<b>SAH10025</b>

**SINGLE ACTING LOW HEIGHT CYLINDERS, LOAD OR SPRING RETURN**



- ✓ Capacity from 10 to 100 Tn, stroke up to 150 mm.
- ✓ Two versions: SP for load return, and SMP for spring return.
- ✓ Low profile for use in confined spaces: machinery positioning, tool fastening, load tests.
- ✓ Body and saddle black nitrided to improve corrosion and wear resistance.
- ✓ Models from 30 to 100 Tn can mount optional tilting saddle.

Capacity		Stroke	Model	Model	Oil Cap.	A	B	D	E	F	H	K	
Tn	kN	mm	LARZEP	LARZEP	cm <sup>3</sup>	mm	mm	mm	mm	mm	mm	mm	
10	109	40	SP01004	SMP01004	64	89	129	66	45	36	14*	2	
20	214	40	SP02004	SMP02004	125	101	141	90	63	56	14*	2	
30	303	60	SP03006	SMP03006	265	125	185	102	75	60	14*	2	
50	486	60	SP05006	SMP05006	425	125	185	127	95	80	16*	2	
100	911	60	SP10006	SMP10006	796	141	201	175	130	110	26	2	
		150	SP10015	SMP10015	1.990	254	404	175	130	110	26	2	



SP load return

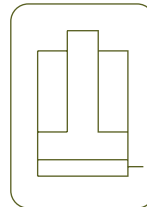
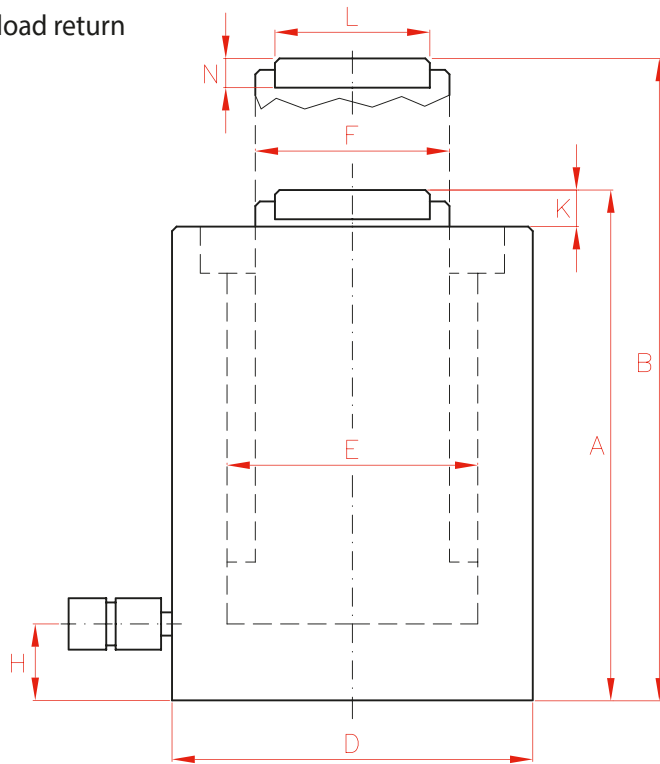

SMP spring return

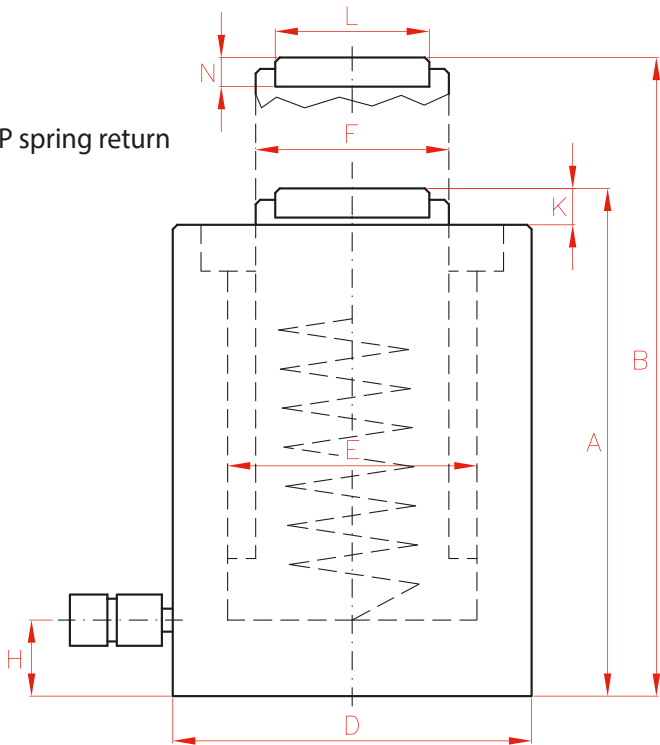

SINGLE ACTING CYLINDERS



Type	<b>SP - SMP</b>
Capacity	10 - 100 Tn
Stroke	40 - 150 mm
Max. pressure	700 bar

J  
Cylinder and pump sets



P.76

SPR  
Single Acting High Tonnage Low Height Cylinder



P.24

AZ3  
Coupler inclined 10°



P.114

AZ04  
Optional Tilting Saddles available



P.118

	L	N	Area cm <sup>2</sup>	Weight kg	Model	Model	With tilting saddle	
	mm	mm			LARZEP	LARZEP	A	Model
	30	-	16	3	<b>SP01004</b>	<b>SMP01004</b>	-	-
	42	-	31	5	<b>SP02004</b>	<b>SMP02004</b>	-	-
	45	11	44	8	<b>SP03006</b>	<b>SMP03006</b>	150	AZ0401
	61	12	71	12	<b>SP05006</b>	<b>SMP05006</b>	152	AZ0402
	88	14	133	25	<b>SP10006</b>	<b>SMP10006</b>	174	AZ0404
	88	14	133	43	<b>SP10015</b>	<b>SMP10015</b>	287	AZ0404



**SINGLE ACTING LOW HEIGHT CYLINDERS, HIGH TONNAGE, LOAD RETURN**



- ✓ Capacity from 140 to 1.100 Tn, stroke up to 300 mm.
- ✓ Load return.
- ✓ Mechanical end of stroke gland avoids over travel at full pressure.
- ✓ Tapped base mounting holes for easy fixing.
- ✓ Models available up to 2.000 Tn lifting capacity per cylinder.

Capacity		Stroke	Model	Oil Cap.	A
Tn	kN	mm	LARZEP	cm <sup>3</sup>	mm
140	1.379	50	SPR14005	1.005	202
		100	SPR14010	2.011	252
		150	SPR14015	3.016	307
		200	SPR14020	4.021	357
		250	SPR14025	5.027	412
		300	SPR14030	6.032	462
220	2.155	50	SPR22005	1.571	206
		100	SPR22010	3.142	256
		150	SPR22015	4.712	311
		200	SPR22020	6.283	361
		250	SPR22025	7.854	416
		300	SPR22030	9.425	466
350	3.367	50	SPR35005	2.454	236
		100	SPR35010	4.909	286
		150	SPR35015	7.363	341
		200	SPR35020	9.817	391
		250	SPR35025	12.272	446
		300	SPR35030	14.726	496



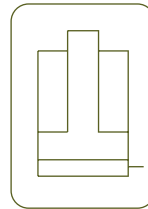
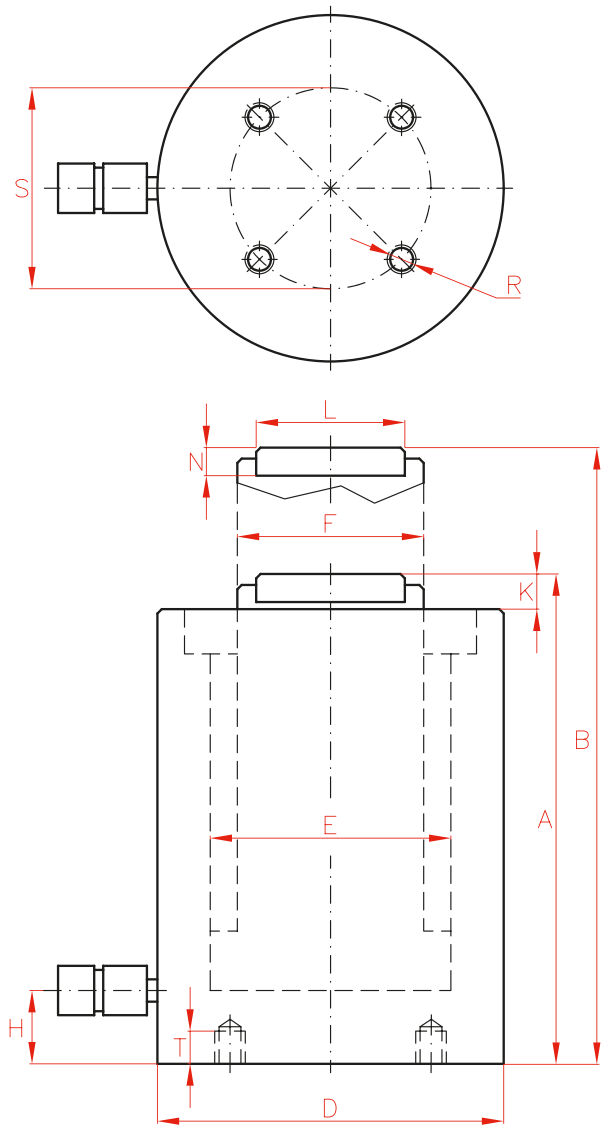

**SINGLE ACTING CYLINDERS**



Type	<b>SPR</b>
Capacity	<b>140 - 1.100 Tn</b>
Stroke	<b>50 - 300 mm</b>
Max. pressure	<b>700 bar</b>

**DDR**  
Double Acting High Tonnage Cylinders



P.60

	B	D	E	F	H	K	L	N	R	S	T	Area	Weight	Model	With tilting saddle	
	mm	mm	mm	mm	mm	mm	mm	mm		mm	mm	cm <sup>2</sup>	kg	LARZEP	A	Model
	252	200	160	140	36	6	88	14	M12	130	22	201	47	<b>SPR14005</b>	235	AZ0404
	352	200	160	140	36	6	88	14	M12	130	22	201	57	<b>SPR14010</b>	285	AZ0404
	457	200	160	140	36	6	88	14	M12	130	22	201	68	<b>SPR14015</b>	340	AZ0404
	557	200	160	140	36	6	88	14	M12	130	22	201	78	<b>SPR14020</b>	390	AZ0404
	662	200	160	140	36	6	88	14	M12	130	22	201	89	<b>SPR14025</b>	445	AZ0404
	762	200	160	140	36	6	88	14	M12	130	22	201	99	<b>SPR14030</b>	495	AZ0404
	256	250	200	160	40	6	111	15	M12	165	22	314	73	<b>SPR22005</b>	243	AZ0405
	356	250	200	160	40	6	111	15	M12	165	22	314	87	<b>SPR22010</b>	293	AZ0405
	461	250	200	160	40	6	111	15	M12	165	22	314	102	<b>SPR22015</b>	348	AZ0405
	561	250	200	160	40	6	111	15	M12	165	22	314	116	<b>SPR22020</b>	398	AZ0405
	666	250	200	160	40	6	111	15	M12	165	22	314	126	<b>SPR22025</b>	453	AZ0405
	766	250	200	160	40	6	111	15	M12	165	22	314	145	<b>SPR22030</b>	503	AZ0405
	286	310	250	200	50	6	178	23	M16	180	30	491	129	<b>SPR35005</b>	280	AZ0408
	386	310	250	200	50	6	178	23	M16	180	30	491	152	<b>SPR35010</b>	330	AZ0408
	491	310	250	200	50	6	178	23	M16	180	30	491	177	<b>SPR35015</b>	385	AZ0408
	591	310	250	200	50	6	178	23	M16	180	30	491	200	<b>SPR35020</b>	435	AZ0408
	696	310	250	200	50	6	178	23	M16	180	30	491	225	<b>SPR35025</b>	490	AZ0408
	796	310	250	200	50	6	178	23	M16	180	30	491	248	<b>SPR35030</b>	540	AZ0408

**HBM / HBE**  
Split-Flow Powerpacks



P.88

**Z12107**  
Air Hydraulic Pump



P.86

**HBM / HBE**  
Powerpack



P.88

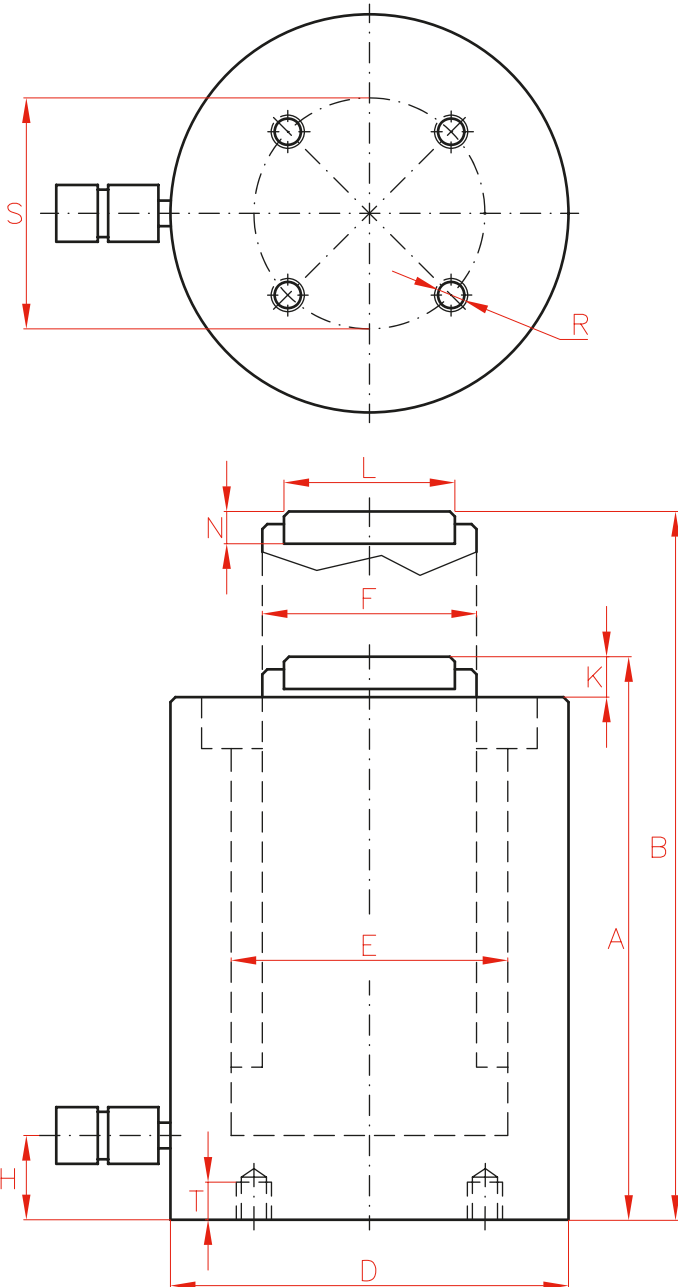

Capacity		Stroke	Model	Oil Cap.	A
Tn	kN	mm	LARZEP	cm <sup>3</sup>	mm
430	4.224	50	SPR43005	3.079	248
		100	SPR43010	6.158	298
		150	SPR43015	9.236	353
		200	SPR43020	12.315	403
		250	SPR43025	15.394	458
		300	SPR43030	18.473	508
560	5.517	50	SPR56005	4.021	268
		100	SPR56010	8.042	318
		150	SPR56015	12.064	373
		200	SPR56020	16.085	423
		250	SPR56025	20.106	488
		300	SPR56030	24.127	538
670	6.600	50	SPR67005	4.811	293
		100	SPR67010	9.621	343
		150	SPR67015	14.432	398
		200	SPR67020	19.242	448
		250	SPR67025	24.053	508
		300	SPR67030	28.863	558
880	8.621	50	SPR88005	6.283	310
		100	SPR88010	12.566	360
		150	SPR88015	18.850	420
		200	SPR88020	25.133	470
		250	SPR88025	31.416	530
		300	SPR88030	37.699	580
1.100	10.910	50	SPR110005	7.952	345
		100	SPR110010	15.904	395
		150	SPR110015	23.856	455
		200	SPR110020	31.809	505
		250	SPR110025	39.761	565
		300	SPR110030	47.713	615



OPTIONAL TILTING SADDLES

Model	L	N	Weight
LARZEP	mm	mm	kg
AZ0404	88	47	2,2
AZ0405	111	52	4,0
AZ0408	178	67	13,0
AZ0411	200	79	19,3
AZ0413	250	105	40,0
AZ0415	325	175	113,0

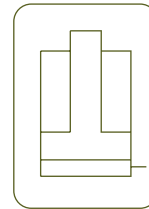
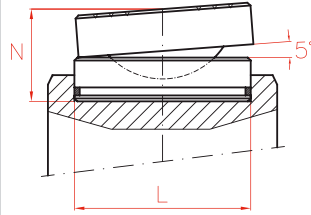

P.118



Type	<b>SPR</b>
Capacity	<b>140 - 1.100 Tn</b>
Stroke	<b>50 - 300 mm</b>
Max. pressure	<b>700 bar</b>

	B	D	E	F	H	K	L	N	R	S	T	Area	Weight	Model	With tilting saddle	
	mm	mm	mm	mm	mm	mm	mm	mm		mm	mm	cm <sup>2</sup>	kg	LARZEP	A	Model
	298	340	280	220	55	8	178	23	M16	205	30	616	163	SPR43005	292	AZ0408
	398	340	280	220	55	8	178	23	M16	205	30	616	189	SPR43010	342	AZ0408
	503	340	280	220	55	8	178	23	M16	205	30	616	219	SPR43015	397	AZ0408
	603	340	280	220	55	8	178	23	M16	205	30	616	245	SPR43020	447	AZ0408
	708	340	280	220	55	8	178	23	M16	205	30	616	275	SPR43025	502	AZ0408
	808	340	280	220	55	8	178	23	M16	205	30	616	301	SPR43030	552	AZ0408
	318	390	320	250	65	8	200	27	M24	250	36	804	232	SPR56005	320	AZ0411
	418	390	320	250	65	8	200	27	M24	250	36	804	267	SPR56010	370	AZ0411
	523	390	320	250	65	8	200	27	M24	250	36	804	306	SPR56015	425	AZ0411
	623	390	320	250	65	8	200	27	M24	250	36	804	340	SPR56020	475	AZ0411
	738	390	320	250	65	8	200	27	M24	250	36	804	389	SPR56025	540	AZ0411
	838	390	320	250	65	8	200	27	M24	250	36	804	423	SPR56030	590	AZ0411
	343	430	350	280	65	8	200	27	M24	275	36	962	312	SPR67005	345	AZ0411
	443	430	350	280	65	8	200	27	M24	275	36	962	355	SPR67010	395	AZ0411
	548	430	350	280	65	8	200	27	M24	275	36	962	404	SPR67015	450	AZ0411
	648	430	350	280	65	8	200	27	M24	275	36	962	447	SPR67020	500	AZ0411
	758	430	350	280	65	8	200	27	M24	275	36	962	501	SPR67025	560	AZ0411
	858	430	350	280	65	8	200	27	M24	275	36	962	545	SPR67030	610	AZ0411
	360	490	400	320	70	10	250	35	M24	330	36	1.257	428	SPR88005	380	AZ0413
	460	490	400	320	70	10	250	35	M24	330	36	1.257	484	SPR88010	430	AZ0413
	570	490	400	320	70	10	250	35	M24	330	36	1.257	555	SPR88015	490	AZ0413
	670	490	400	320	70	10	250	35	M24	330	36	1.257	611	SPR88020	540	AZ0413
	780	490	400	320	70	10	250	35	M24	330	36	1.257	681	SPR88025	600	AZ0413
	880	490	400	320	70	10	250	35	M24	330	36	1.257	737	SPR88030	650	AZ0413
	395	550	450	360	80	10	325	55	M24	375	36	1.590	598	SPR110005	465	AZ0415
	495	550	450	360	80	10	325	55	M24	375	36	1.590	670	SPR110010	515	AZ0415
	605	550	450	360	80	10	325	55	M24	375	36	1.590	740	SPR110015	575	AZ0415
	705	550	450	360	80	10	325	55	M24	375	36	1.590	803	SPR110020	625	AZ0415
	815	550	450	360	80	10	325	55	M24	375	36	1.590	883	SPR110025	685	AZ0415
	915	550	450	360	80	10	325	55	M24	375	36	1.590	943	SPR110030	735	AZ0415

**SINGLE ACTING LOW PROFILE CYLINDERS, LOAD OR SPRING RETURN**



- ✓ Capacity from 4 to 150 Tn, stroke up to 16 mm.
- ✓ Two versions: SX for load return, and SMX for spring return.
- ✓ For use in confined spaces: machinery positioning, tool fastening.
- ✓ With two parallel faces for horizontal operation.
- ✓ Mounting bolt holes for easy fixing.
- ✓ Special coating as standard to improve corrosion and side load resistance.
- ✓ SX models from 50 to 150 Tn include removable saddle and can be fitted with optional tilting saddles.

**SX & SMX**

\*Coupler inclined 5°,  
except 100 Tn and 150 Tn, that is 0°



P.114

**AZ04**

Optional Tilting Saddles available for SX  
models from 50 to 150 Tn



P.118

**W**

Single Acting Hand Pumps



P.80





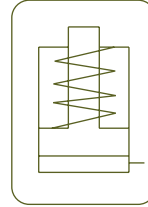
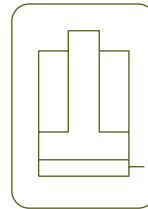
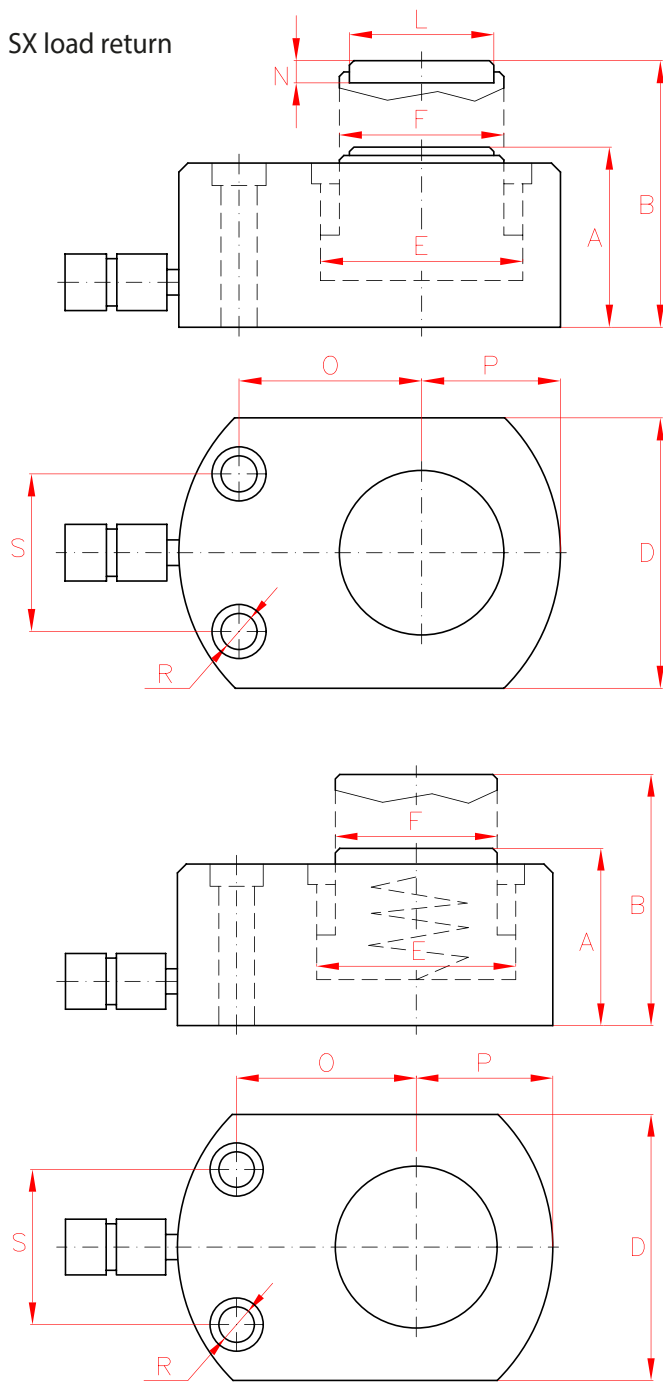

**SINGLE ACTING CYLINDERS**



Type	<b>SX - SMX</b>
Capacity	4 - 150 Tn
Stroke	6 - 16 mm
Max. pressure	700 bar

SX - SMX CYLINDERS

**SLX**  
Low Height Single Acting Telescopic Cylinders



P.30

**STX**  
Single Acting Pancake Lock Nut Cylinders



P.46

SMX spring return

Capacity		Stroke	Model	Model	Oil Cap.	A	B	D	E	F	L	N	O	P	S	R	Area	Weight
Tn	kN	mm	LARZEP	LARZEP	cm <sup>3</sup>	mm	mm	mm	mm	mm	mm	mm	mm	mm	mm	mm	cm <sup>2</sup>	kg
4	44	6	SX00406	SMX00406	4	33	39	41	28,5	25	21	-	20	21	28	5,5	6	0,8
		16	SX00416	SMX00416	11	43	59	41	28,5	25	21	-	20	21	28	5,5	6	1,2
10	100	11	SX01011	SMX01011	16	43	54	56	43	38	30	-	33	29	37	6,5	15	1,6
22	228	11	SX02211	SMX02211	37	52	63	80	65	57	42	-	39	41	50	9	33	2,8
30	287	13	SX03013	SMX03013	55	59	72	95	73	60	44	-	46	47	52	11	42	4,1
50	487	16	SX05016	SMX05016	114	68	84	114	95	78	61	12	56	58	67	13	71	6,6
75	713	16	SX07516	SMX07516	167	79	95	140	115	95	61	12	66	70,5	75	13	104	12,5
100	954	16	SX10016	SMX10016	223	87	103	162	133	108	88	14	70	89	76	6,6	139	15,0
150	1.450	16	SX15016	SMX15016	338	100	116	194	164	134	88	14	78	108	117	9	211	25,0

**SINGLE ACTING, LOW HEIGHT TELESCOPIC CYLINDERS**



- ✓ Capacity from 4 to 75 Tn, stroke up to 40 mm.
- ✓ Models with two and three stages.
- ✓ Load return.
- ✓ For use in confined spaces: machinery positioning, tool fastening.
- ✓ Mounting bolt holes for easy fixing.
- ✓ All models are black nitrided to improve corrosion and side load resistance.

Capacity	Stroke	Model	1 <sup>st</sup> Stage			2 <sup>nd</sup> Stage			3 <sup>rd</sup> Stage			Oil Cap.
			Capacity	Stroke	Area	Capacity	Stroke	Area	Capacity	Stroke	Area	
Tn	mm	LARZEP	kN	mm	cm <sup>2</sup>	kN	mm	cm <sup>2</sup>	kN	mm	cm <sup>2</sup>	cm <sup>3</sup>
4	17	SLX00417	111	11	15,9	43	6	6,2	-	-	-	21,2
	23	SLX00423	232	11	33,2	111	7	15,9	43	5	6,2	50,7
11	18	SLX01118	232	11	33,2	111	7	15,9	-	-	-	47,6
	40	SLX01140	727	16	103,9	309	13	44,2	111	11	15,9	241,2
23	27	SLX02327	496	16	70,9	232	11	33,2	-	-	-	150,0
	32	SLX02332	929	16	132,7	496	10	70,9	232	6	33,2	303,1
30	29	SLX03129	727	16	103,9	309	13	44,2	-	-	-	223,7
50	26	SLX05026	957	16	136,8	496	10	70,9	-	-	-	238,2
75	26	SLX075026	1.407	16	201,1	727	10	103,9	-	-	-	425,7



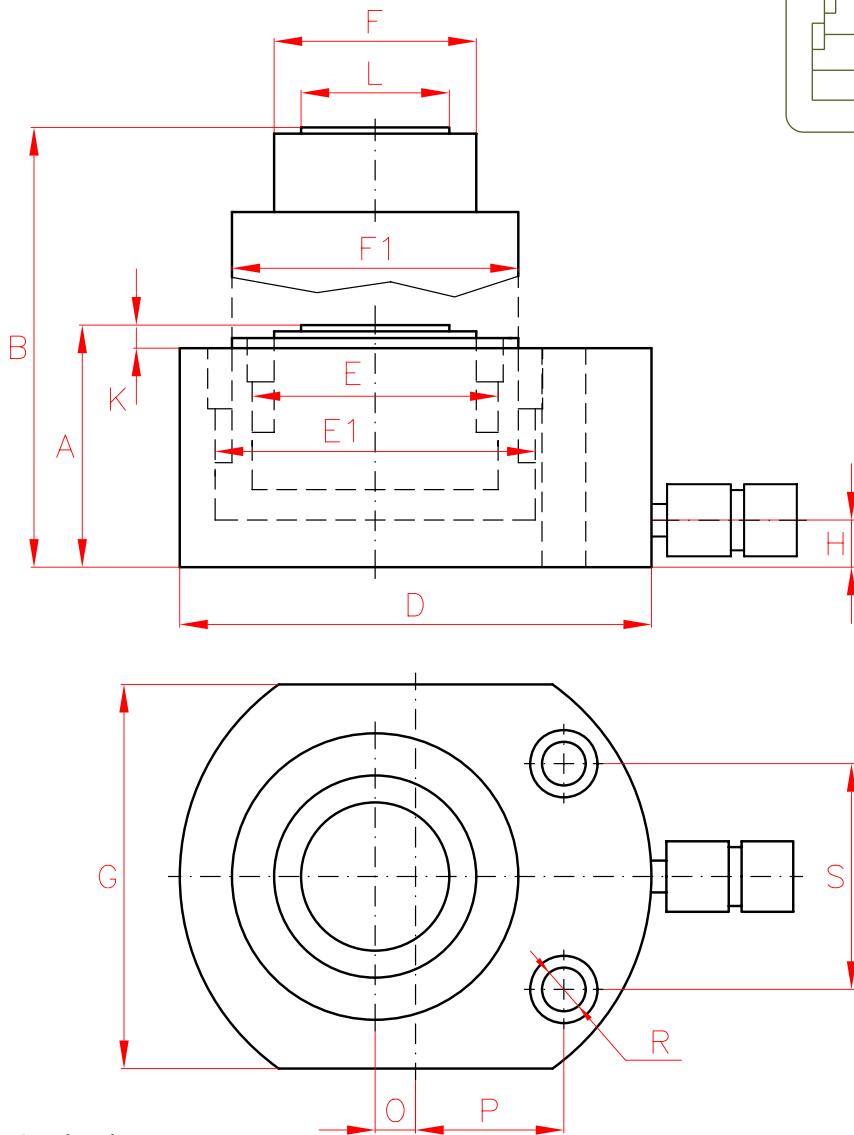

SLX load return

S/A L/H TELESCOPIC CYLINDERS



Type	<b>SLX</b>
Capacity	4 - 75 Tn
Stroke	17 - 40 mm
Max. pressure	700 bar

W Single Acting Hand Pumps



P.80

SLX \*Coupler inclined 5° on 4 Tn Cylinders and SLX01118



P.114

	A	B	D	E	E1	F	F1	G	H	K	L	O	P	R	S	Weight	Model
	LARZEP																
	mm	mm	mm	mm	mm	mm	mm	mm	mm	mm	mm	mm	mm	mm	mm	kg	
	45	62	83	28	45	25	38	56	20	0,5	20,4	12,5	21	6,5	37	1,8	SLX00417
	54	77	102	28	65	25	57	80	20	0,5	20,4	10,0	29	9,0	50	3,1	SLX00423
	55	73	102	45	65	38	57	80	20	1,0	30	10,0	29	9,0	50	3,0	SLX01118
	89	129	165	45	115	38	95	140	25	1,0	36	12,0	54	13,0	76	13,1	SLX01140
	75	102	140	65	95	57	78	114	20	1,0	42	12,0	44	13,0	67	7,6	SLX02327
	96	128	178	65	132	57	115	162	29	1,0	50	-	70	6,5	76	17,3	SLX02332
	89	118	165	75	115	60	95	140	25	1,0	44	12,0	54	13,0	76	13,0	SLX03129
	96	122	178	95	132	78	115	162	29	2,0	66	-	70	6,5	76	17,3	SLX05026
	114	140	216	115	160	95	137	196	35	2,0	83	-	78	9,0	117	30,4	SLX07526

**SINGLE ACTING LOCK NUT CYLINDERS, LOAD RETURN**



- ✓ Capacity from 30 to 1.100 Tn, stroke up to 300 mm.
- ✓ The lock nut holds the load mechanically for extended periods of time.
- ✓ Load return. Spring return available as special.
- ✓ Lock nut tested under 50% overload.
- ✓ Hydraulic end of stroke overflow port. Red band warning.  
Mechanical end of stroke available as special.
- ✓ Body and saddle black nitrided to improve corrosion and wear resistance.
- ✓ Used for foundation supporting, bridge construction and shipbuilding.
- ✓ For confined spaces, use STX models.



DTC models, double acting cylinders up to 2.000 Tn, low height with lock nut available upon request.



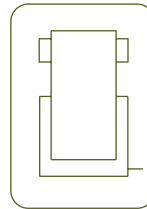

**S/A LOCK NUT CYLINDERS**



Type	<b>STR</b>
Capacity	<b>30 - 1.100 Tn</b>
Stroke	<b>50 - 300 mm</b>
Max. pressure	<b>700 bar</b>

STR CYLINDERS



**AZ04**  
Optional Tilting Saddles available



P.112



**STX**  
Single Acting Pancake Lock Nut Cylinders



P.46

**SAT**  
Aluminium Single Acting Cylinders with Lock Nut



P.38



**SATM**  
Aluminium Single Acting Spring Return Cylinders with Lock Nut and Stop Ring



P.42



**AZ3**

Coupler 3/8"-18 NPT included



P.114

**AP2**

Hoses



P.112

**AV - AVD - AT - AY**

Pressure Gauges



P.123

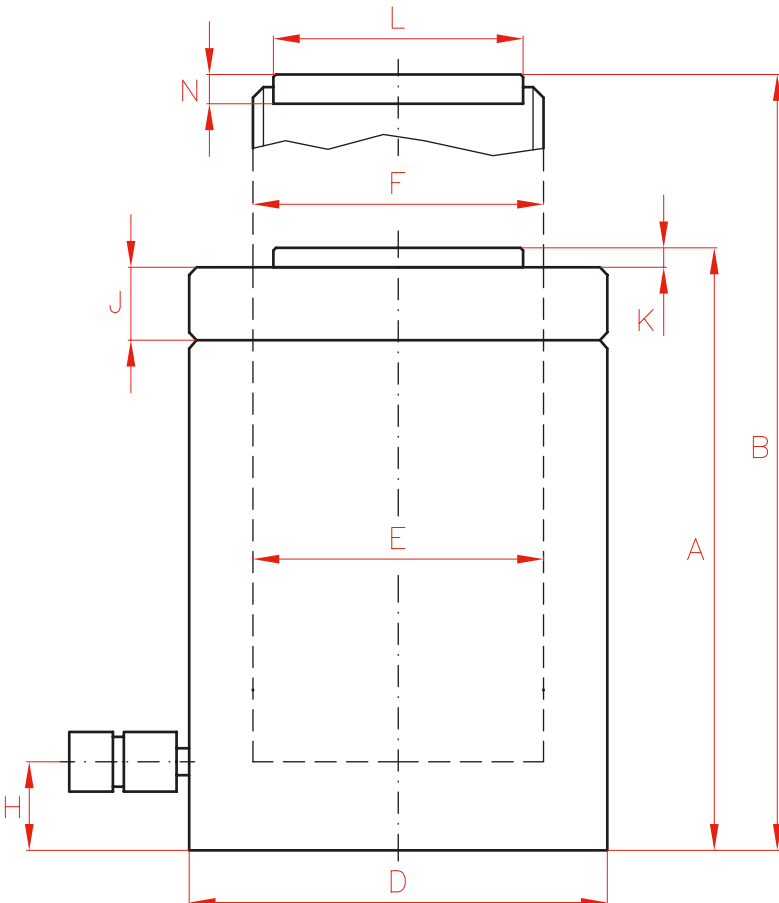

Capacity		Stroke	Model	Oil Cap.	A
Tn	kN	mm	LARZEP	cm <sup>3</sup>	mm
30	303	50	STR03005	221	169
		100	STR03010	442	219
		150	STR03015	663	269
		200	STR03020	884	319
		250	STR03025	1.105	369
		300	STR03030	1.325	419
50	487	50	STR05005	355	155
		100	STR05010	709	205
		150	STR05015	1.062	260
		200	STR05020	1.418	310
		250	STR05025	1.772	365
		300	STR05030	2.127	415
100	911	50	STR10005	664	180
		100	STR10010	1.327	230
		150	STR10015	1.991	285
		200	STR10020	2.654	335
		250	STR10025	3.318	390
		300	STR10030	3.981	440
140	1.380	50	STR14005	1.005	201
		100	STR14010	2.011	251
		150	STR14015	3.016	311
		200	STR14020	4.021	361
		250	STR14025	5.026	421
		300	STR14030	6.032	471
220	2.156	50	STR22005	1.571	208
		100	STR22010	3.142	258
		150	STR22015	4.712	318
		200	STR22020	6.283	368
		250	STR22025	7.854	433
		300	STR22030	9.425	483
350	3.368	50	STR35005	2.545	238
		100	STR35010	4.909	288
		150	STR35015	7.363	348
		200	STR35020	9.817	398
		250	STR35025	12.272	458
		300	STR35030	14.726	508



OPTIONAL TILTING SADDLES

Model	L	N	Weight
LARZEP	mm	mm	kg
AZ0401	45	36	0,4
AZ0402	61	39	0,8
AZ0404	88	47	2,2
AZ0405	111	52	4,0
AZ0408	178	67	13,0

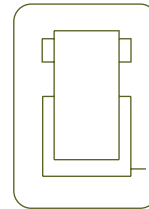
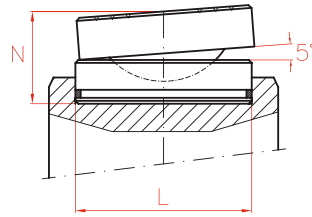

P.118



Type	<b>STR</b>
Capacity	<b>30 - 1.100 Tn</b>
Stroke	<b>50 - 300 mm</b>

STR CYLINDERS

	B	D	E	F	H	J	K	L	N	Area	Weight	Model	With tilting saddle	
	mm	mm	mm	mm	mm	mm	mm	mm	mm	cm <sup>2</sup>	kg	LARZEP	A	Model
	219	100	75	Tr 75x4	25	30	3	45	11	44	10,3	STR03005	194	AZ0401
	319	100	75	Tr 75x4	25	30	3	45	11	44	13,2	STR03010	244	AZ0401
	419	100	75	Tr 75x4	25	30	3	45	11	44	17,2	STR03015	294	AZ0401
	519	100	75	Tr 75x4	25	30	3	45	11	44	19,2	STR03020	344	AZ0401
	619	100	75	Tr 75x4	25	30	3	45	11	44	22,5	STR03025	394	AZ0401
	719	100	75	Tr 75x4	25	30	3	45	11	44	25,9	STR03030	444	AZ0401
	205	125	95	Tr 95x4	25	21	3	61	12	71	15	STR05005	182	AZ0402
	305	125	95	Tr 95x4	25	21	3	61	12	71	20	STR05010	232	AZ0402
	410	125	95	Tr 95x4	25	21	3	61	12	71	25	STR05015	287	AZ0402
	510	125	95	Tr 95x4	25	21	3	61	12	71	30	STR05020	337	AZ0402
	615	125	95	Tr 95x4	25	21	3	61	12	71	35	STR05025	392	AZ0402
	715	125	95	Tr 95x4	25	21	3	61	12	71	40	STR05030	442	AZ0402
	230	170	130	Tr 130x6	30	31	3	88	14	133	31	STR10005	213	AZ0404
	330	170	130	Tr 130x6	30	31	3	88	14	133	40	STR10010	263	AZ0404
	435	170	130	Tr 130x6	30	31	3	88	14	133	50	STR10015	318	AZ0404
	535	170	130	Tr 130x6	30	31	3	88	14	133	59	STR10020	368	AZ0404
	640	170	130	Tr 130x6	30	31	3	88	14	133	69	STR10025	423	AZ0404
	740	170	130	Tr 130x6	30	31	3	88	14	133	78	STR10030	473	AZ0404
	251	200	160	Tr 160x6	35	38	3	88	14	201	49	STR14005	234	AZ0404
	351	200	160	Tr 160x6	35	38	3	88	14	201	61	STR14010	284	AZ0404
	461	200	160	Tr 160x6	35	38	3	88	14	201	76	STR14015	344	AZ0404
	561	200	160	Tr 160x6	35	38	3	88	14	201	88	STR14020	394	AZ0404
	671	200	160	Tr 160x6	35	38	3	88	14	201	103	STR14025	454	AZ0404
	771	200	160	Tr 160x6	35	38	3	88	14	201	115	STR14030	504	AZ0404
	258	250	200	Tr 200x6	40	40	3	111	15	314	79	STR22005	245	AZ0405
	358	250	200	Tr 200x6	40	40	3	111	15	314	98	STR22010	295	AZ0405
	468	250	200	Tr 200x6	40	40	3	111	15	314	121	STR22015	355	AZ0405
	568	250	200	Tr 200x6	40	40	3	111	15	314	140	STR22020	405	AZ0405
	683	250	200	Tr 200x6	40	40	3	111	15	314	165	STR22025	470	AZ0405
	783	250	200	Tr 200x6	40	40	3	111	15	314	184	STR22030	520	AZ0405
	288	310	250	Tr 250x6	50	50	3	178	23	491	139	STR35005	282	AZ0408
	388	310	250	Tr 250x6	50	50	3	178	23	491	169	STR35010	332	AZ0408
	498	310	250	Tr 250x6	50	50	3	178	23	491	204	STR35015	392	AZ0408
	598	310	250	Tr 250x6	50	50	3	178	23	491	233	STR35020	442	AZ0408
	708	310	250	Tr 250x6	50	50	3	178	23	491	269	STR35025	502	AZ0408
	808	310	250	Tr 250x6	50	50	3	178	23	491	298	STR35030	552	AZ0408

**HBM / HBE**  
Split-Flow Powerpacks



P.88

**Z12107**  
Air Hydraulic Pump



P.86

**W**  
Single Acting Hand Pumps



P.80

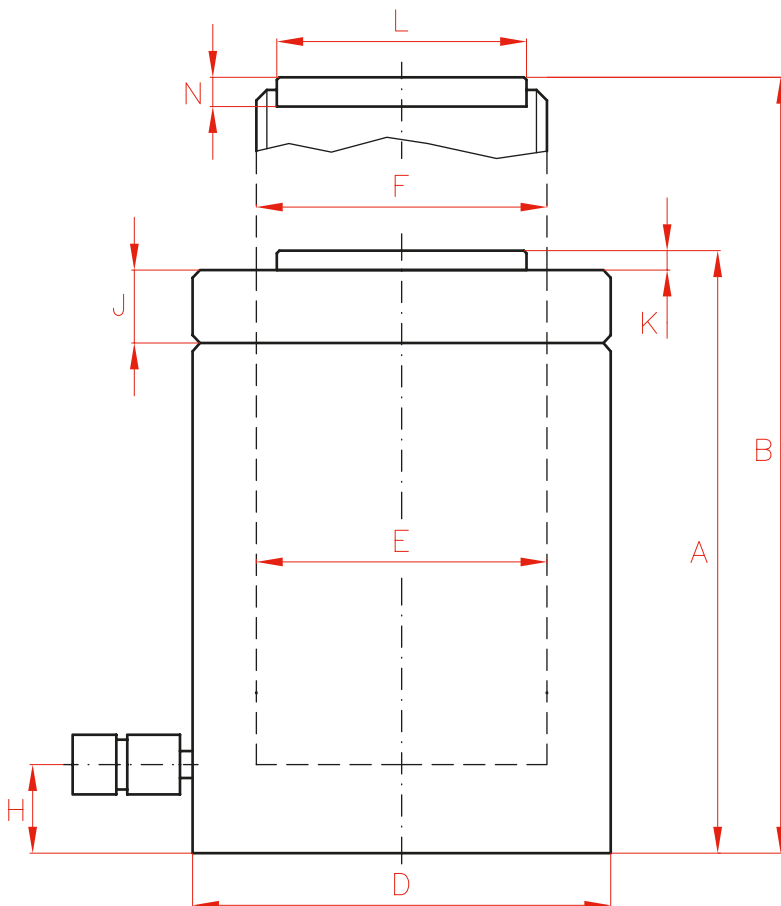

Capacity		Stroke	Model	Oil Cap.	A
Tn	kN	mm	LARZEP	cm <sup>3</sup>	mm
430	4.224	50	STR43005	3.079	250
		100	STR43010	6.158	300
		150	STR43015	9.236	365
		200	STR43020	12.315	415
		250	STR43025	15.394	480
		300	STR43030	18.473	530
560	5.517	50	STR56005	4.021	280
		100	STR56010	8.042	330
		150	STR56015	12.064	395
		200	STR56020	16.085	445
		250	STR56025	20.106	510
		300	STR56030	24.127	560
670	6.600	50	STR67005	4.811	305
		100	STR67010	9.621	355
		150	STR67015	14.432	420
		200	STR67020	19.242	470
		250	STR67025	24.053	535
		300	STR67030	28.863	585
880	8.620	50	STR88005	6.283	325
		100	STR88010	12.566	375
		150	STR88015	18.849	440
		200	STR88020	25.133	490
		250	STR88025	31.416	555
		300	STR88030	37.699	605
1.100	10.905	50	STR110005	7.952	340
		100	STR110010	15.904	420
		150	STR110015	23.856	485
		200	STR110020	31.808	535
		250	STR110025	39.760	600
		300	STR110030	47.713	650



OPTIONAL TILTING SADDLES

Model	L	N	Weight
LARZEP	mm	mm	kg
AZ0408	178	67	13,0
AZ0411	200	79	19,3
AZ0413	250	105	40,0
AZ0415	325	175	113,0

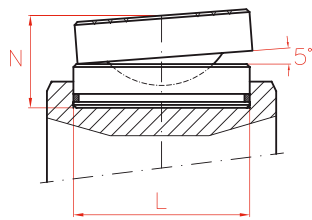

P.118

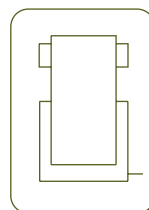

Type	STR
Capacity	30 - 1.100 Tn
Stroke	50 - 300 mm
Max. pressure	700 bar

	B	D	E	F	H	J	K	L	N	Area	Weight	Model	With tilting saddle	
	mm	mm	mm	mm	mm	mm	mm	mm	mm	cm <sup>2</sup>	kg	LARZEP	A	Model
	300	340	280	Tr 280x6	55	55	5	178	23	616	175	STR43005	294	AZ0408
	400	340	280	Tr 280x6	55	55	5	178	23	616	210	STR43010	344	AZ0408
	515	340	280	Tr 280x6	55	55	5	178	23	616	258	STR43015	409	AZ0408
	615	340	280	Tr 280x6	55	55	5	178	23	616	292	STR43020	459	AZ0408
	730	340	280	Tr 280x6	55	55	5	178	23	616	338	STR43025	524	AZ0408
	830	340	280	Tr 280x6	55	55	5	178	23	616	373	STR43030	574	AZ0408
	330	390	320	Tr 320x6	65	60	5	200	27	804	263	STR56005	332	AZ0411
	430	390	320	Tr 320x6	65	60	5	200	27	804	310	STR56010	382	AZ0411
	545	390	320	Tr 320x6	65	60	5	200	27	804	370	STR56015	447	AZ0411
	645	390	320	Tr 320x6	65	60	5	200	27	804	417	STR56020	497	AZ0411
	760	390	320	Tr 320x6	65	60	5	200	27	804	478	STR56025	562	AZ0411
	860	390	320	Tr 320x6	65	60	5	200	27	804	524	STR56030	612	AZ0411
	355	430	350	Tr 350x6	65	75	5	200	27	962	343	STR67005	357	AZ0411
	455	430	350	Tr 350x6	65	75	5	200	27	962	400	STR67010	407	AZ0411
	570	430	350	Tr 350x6	65	75	5	200	27	962	473	STR67015	472	AZ0411
	670	430	350	Tr 350x6	65	75	5	200	27	962	530	STR67020	522	AZ0411
	785	430	350	Tr 350x6	65	75	5	200	27	962	604	STR67025	587	AZ0411
	885	430	350	Tr 350x6	65	75	5	200	27	962	660	STR67030	637	AZ0411
	375	490	400	Tr 400x6	70	85	5	250	35	1.256	474	STR88005	395	AZ0413
	475	490	400	Tr 400x6	70	85	5	250	35	1.256	548	STR88010	445	AZ0413
	590	490	400	Tr 400x6	70	85	5	250	35	1.256	643	STR88015	510	AZ0413
	690	490	400	Tr 400x6	70	85	5	250	35	1.256	717	STR88020	560	AZ0413
	805	490	400	Tr 400x6	70	85	5	250	35	1.256	813	STR88025	625	AZ0413
	905	490	400	Tr 400x6	70	85	5	250	35	1.256	886	STR88030	675	AZ0413
	390	550	450	Tr 450x6	80	95	5	325	55	1.590	681	STR110005	460	AZ0415
	520	550	450	Tr 450x6	80	95	5	325	55	1.590	773	STR110010	540	AZ0415
	635	550	450	Tr 450x6	80	95	5	325	55	1.590	894	STR110015	605	AZ0415
	735	550	450	Tr 450x6	80	95	5	325	55	1.590	987	STR110020	655	AZ0415
	850	550	450	Tr 450x6	80	95	5	325	55	1.590	1.107	STR110025	720	AZ0415
	950	550	450	Tr 450x6	80	95	5	325	55	1.590	1.200	STR110030	770	AZ0415

**ALUMINIUM SINGLE ACTING CYLINDERS, LOCK NUT, LOAD RETURN**

- ✓ Capacity from 30 to 200 Tn, stroke up to 300 mm.
- ✓ Load return. Lock nut tested under 50% overload.
- ✓ Made out of high strength aluminium alloy.
- ✓ All aluminium parts are treated to improve resistance and extend working life.
- ✓ Hydraulic end of stroke overflow port. Red band warning.  
Mechanical end of stroke in SATM models.
- ✓ Used for foundation supporting, bridge construction, buildings and shipbuilding.
- ✓ Lightweight. Over 40% weight reduction when compared with steel equivalent.
- ✓ Fitted with steel base plate and saddle for wear resistance.
- ✓ The lock nut holds the load mechanically for long periods of time.
- ✓ Not suitable for high cycle applications.



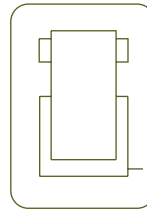

Larzep designs and manufactures special cylinders and fixing systems. For further information, please contact our Internal Sales department.

**ALUM. S/A LOCK NUT CYLINDERS**



Type	<b>SAT</b>
Capacity	30 - 200 Tn
Stroke	50 - 300 mm
Max. pressure	700 bar

**SATM**  
Aluminium Single Acting Spring Return Cylinders with Lock Nut and Stop Ring



P.42

**STR**  
Single Acting Lock Nut Cylinders



P.32

**DDA**  
Double Acting Aluminium Cylinders



P.64

**WA**  
Aluminium Hand Pumps



P.82

**AZ04**  
Optional Tilting Saddles available



P.118

**AP2**  
Hoses



P.112

**HBM / HBE**  
Powerpack



P.88

**Z12107**  
Air Hydraulic Pump



P.86

**WA**  
Aluminium Hand Pumps



P.82

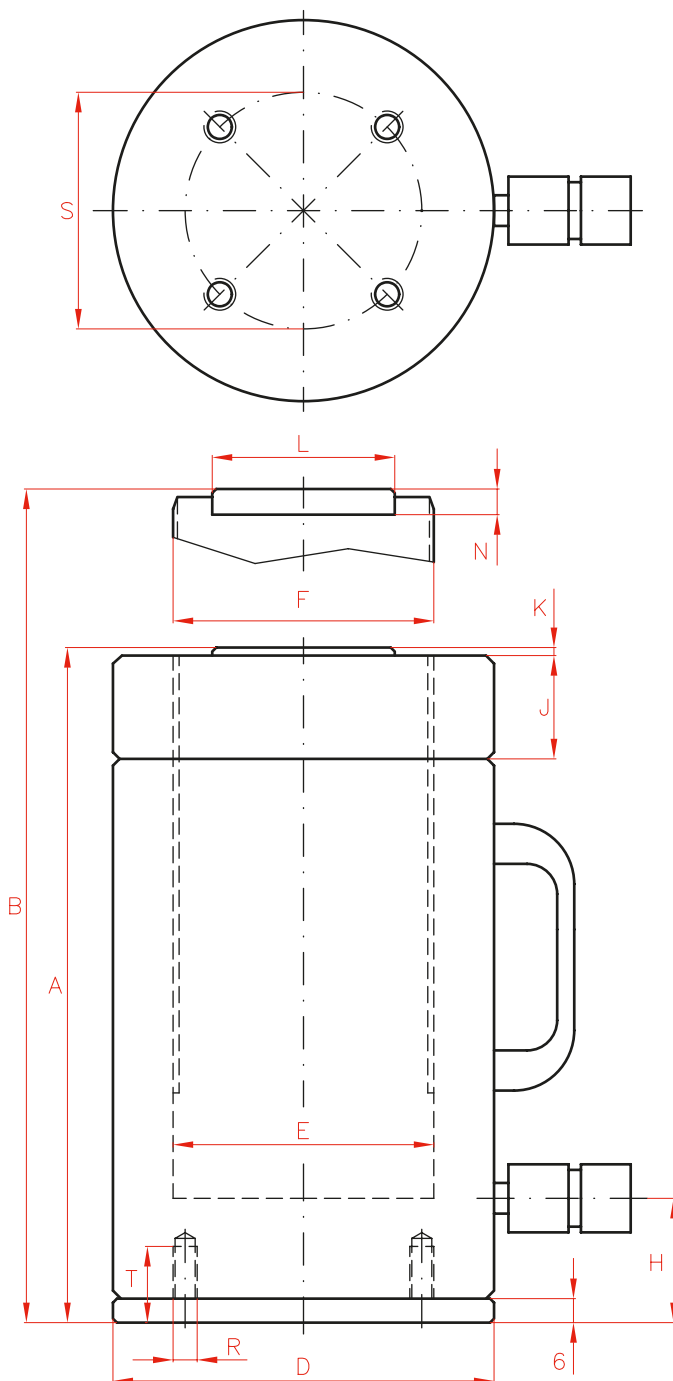

Capacity		Stroke	Model	Oil Cap.	A	B	
Tn	kN	mm	LARZEP	cm <sup>3</sup>	mm	mm	
30	303	50	SAT03005	221	204	254	
		100	SAT03010	442	254	354	
		150	SAT03015	663	304	454	
		200	SAT03020	884	354	554	
		250	SAT03025	1.104	404	654	
		300	SAT03030	1.325	454	754	
50	487	50	SAT05005	354	193	243	
		100	SAT05010	709	243	343	
		150	SAT05015	1.063	293	443	
		200	SAT05020	1.418	353	553	
		250	SAT05025	1.772	403	653	
		300	SAT05030	2.126	453	753	
100	911	50	SAT10005	664	216	266	
		100	SAT10010	1.327	266	366	
		150	SAT10015	1.991	326	476	
		200	SAT10020	2.655	376	576	
		250	SAT10025	3.318	446	696	
		300	SAT10030	3.982	496	796	
140	1.380	50	SAT14005	1.005	234	284	
		100	SAT14010	2.011	284	384	
		150	SAT14015	3.016	345	495	
		200	SAT14020	4.021	395	595	
		250	SAT14025	5.027	465	715	
		300	SAT14030	6.032	515	815	
200	1.946	50	SAT20005	1.418	249	299	
		100	SAT20010	2.835	299	399	
		150	SAT20015	4.253	364	514	
		200	SAT20020	5.671	414	614	
		250	SAT20025	7.088	479	729	
		300	SAT20030	8.506	529	829	



OPTIONAL TILTING SADDLES

Model	L	N	Weight
LARZEP	mm	mm	kg
AZ0401	45	36	0,4
AZ0402	61	39	0,8
AZ0404	88	47	2,2
AZ0405	111	52	4,0

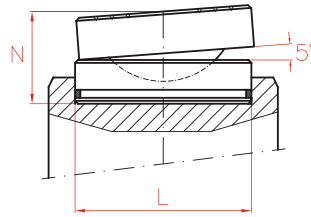

P.118



Type	<b>SAT</b>
Capacity	<b>30 - 200 Tn</b>
Stroke	<b>50 - 300 mm</b>
Max. pressure	<b>700 bar</b>

SAT CYLINDERS

	D	E	F	H	J	K	L	N	R	S	T	Area	Weight	Model	With tilting saddle	
	mm	mm	mm	mm	mm	mm	mm	mm		mm	mm	cm <sup>2</sup>	kg	LARZEP	A	Model
	105	75	Tr 75x4	24	25	3	45	11	M6	85	19	44	4,4	SAT03005	229	AZ0401
	105	75	Tr 75x4	24	25	3	45	11	M6	85	19	44	5,6	SAT03010	279	AZ0401
	105	75	Tr 75x4	24	25	3	45	11	M6	85	19	44	6,8	SAT03015	329	AZ0401
	105	75	Tr 75x4	24	25	3	45	11	M6	85	19	44	8,0	SAT03020	379	AZ0401
	105	75	Tr 75x4	24	25	3	45	11	M6	85	19	44	9,2	SAT03025	429	AZ0401
	105	75	Tr 75x4	24	25	3	45	11	M6	85	19	44	10,5	SAT03030	479	AZ0401
	135	95	Tr 95x4	26	35	3	61	12	M6	115	19	71	7,9	SAT05005	220	AZ0402
	135	95	Tr 95x4	26	35	3	61	12	M6	115	19	71	9,9	SAT05010	270	AZ0402
	135	95	Tr 95x4	26	35	3	61	12	M6	115	19	71	11,9	SAT05015	320	AZ0402
	135	95	Tr 95x4	26	35	3	61	12	M6	115	19	71	13,9	SAT05020	380	AZ0402
	135	95	Tr 95x4	26	35	3	61	12	M6	115	19	71	15,9	SAT05025	430	AZ0402
	135	95	Tr 95x4	26	35	3	61	12	M6	115	19	71	17,9	SAT05030	480	AZ0402
	180	130	Tr 130x6	32	42	3	88	14	M6	160	19	133	15,6	SAT10005	249	AZ0404
	180	130	Tr 130x6	32	42	3	88	14	M6	160	19	133	19,2	SAT10010	299	AZ0404
	180	130	Tr 130x6	32	42	3	88	14	M6	160	19	133	22,8	SAT10015	359	AZ0404
	180	130	Tr 130x6	32	42	3	88	14	M6	160	19	133	26,4	SAT10020	409	AZ0404
	180	130	Tr 130x6	32	42	3	88	14	M6	160	19	133	29,9	SAT10025	479	AZ0404
	180	130	Tr 130x6	32	42	3	88	14	M6	160	19	133	33,5	SAT10030	529	AZ0404
	225	160	Tr 160x6	43	50	3	88	14	M6	200	19	201	26,0	SAT14005	267	AZ0404
	225	160	Tr 160x6	43	50	3	88	14	M6	200	19	201	31,6	SAT14010	317	AZ0404
	225	160	Tr 160x6	43	50	3	88	14	M6	200	19	201	37,2	SAT14015	378	AZ0404
	225	160	Tr 160x6	43	50	3	88	14	M6	200	19	201	43,1	SAT14020	428	AZ0404
	225	160	Tr 160x6	43	50	3	88	14	M6	200	19	201	48,3	SAT14025	498	AZ0404
	225	160	Tr 160x6	43	50	3	88	14	M6	200	19	201	53,9	SAT14030	548	AZ0404
	265	190	Tr 190x6	43	60	3	111	15	M6	225	19	284	42,9	SAT20005	286	AZ0405
	265	190	Tr 190x6	43	60	3	111	15	M6	225	19	284	50,6	SAT20010	336	AZ0405
	265	190	Tr 190x6	43	60	3	111	15	M6	225	19	284	58,4	SAT20015	401	AZ0405
	265	190	Tr 190x6	43	60	3	111	15	M6	225	19	284	66,1	SAT20020	451	AZ0405
	265	190	Tr 190x6	43	60	3	111	15	M6	225	19	284	73,9	SAT20025	516	AZ0405
	265	190	Tr 190x6	43	60	3	111	15	M6	225	19	284	81,6	SAT20030	566	AZ0405

**ALUMINIUM SINGLE ACTING CYLINDERS, LOCK NUT, STOP RING, SPRING RETURN**

- ✓ Capacity from 30 to 200 Tn, stroke up to 300 mm.
- ✓ Spring return. Lock nut tested under 50% overload.
- ✓ Mechanical end of stroke gland avoids over travel at full pressure.
- ✓ Made out of high strength aluminium alloy.
- ✓ All aluminium parts are treated to improve resistance and extend working life.
- ✓ Lightweight. Over 40% weight reduction when compared with steel equivalent.
- ✓ Fitted with steel base plate and saddle for wear resistance.
- ✓ The lock nut holds the load mechanically for extended periods of time.
- ✓ Not suitable for high cycle applications.

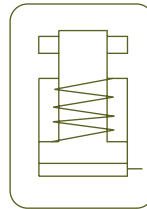

**ALUM. S/A LOCK NUT S/R CYLINDERS**



Type **SATM**

Capacity **30 - 200 Tn**

Stroke **50 - 300 mm**

Max. pressure **700 bar**

SATM CYLINDERS



**SAT**  
Aluminium Single Acting Cylinders  
Load Return with Lock Nut



P.38

**STR**  
Single Acting Lock Nut Cylinders



P.32

Larzep designs and manufactures special cylinders and fixing systems. For further information, please contact our Internal Sales department.

**AZ3**  
Coupler 3/8"-18 NPT included



P.114

**AP2**  
Hoses



P.112

**STX**  
Single Acting Pancake Lock Nut Cylinders



P.46

**AZ04**  
Optional Tilting Saddles available



P.118

**WA**  
Aluminium Hand Pumps



P.82

**DDA**  
Double Acting Aluminium Cylinders



P.64



**HBM / HBE**  
Powerpack



P.88

**Z1207**  
Air Hydraulic Pump



P.86

**WA**  
Aluminium Hand Pumps



P.82

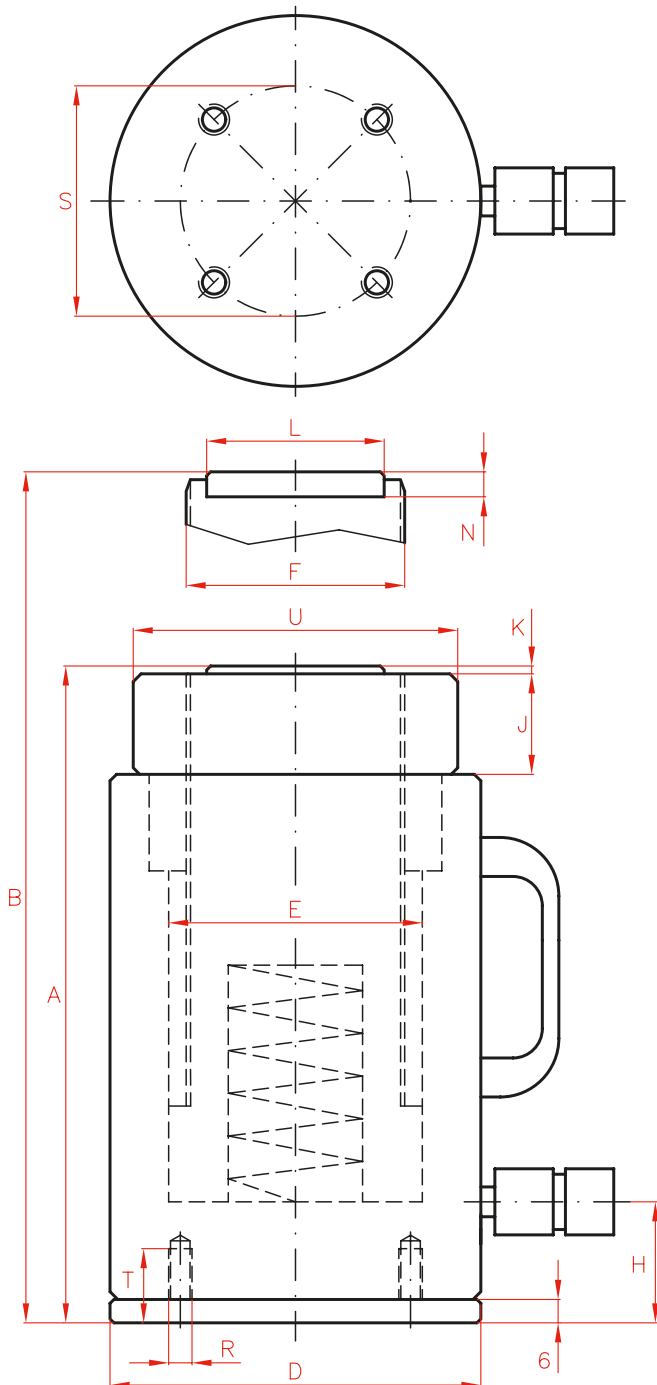

Capacity		Stroke	Model	Oil Cap.	A	B	D	
Tn	kN	mm	LARZEP	cm <sup>3</sup>	mm	mm	mm	
30	303	50	SATM03005	221	204	254	105	
		100	SATM03010	442	254	354	105	
		150	SATM03015	663	304	454	105	
		200	SATM03020	884	354	554	105	
		250	SATM03025	1.104	404	654	105	
		300	SATM03030	1.325	454	754	105	
50	487	50	SATM05005	355	216	266	135	
		100	SATM05010	709	266	366	135	
		150	SATM05015	1.063	316	466	135	
		200	SATM05020	1.418	366	566	135	
		250	SATM05025	1.772	416	666	135	
		300	SATM05030	2.127	466	766	135	
100	911	50	SATM10005	663	258	308	180	
		100	SATM10010	1.326	308	408	180	
		150	SATM10015	1.989	358	508	180	
		200	SATM10020	2.652	408	608	180	
		250	SATM10025	3.315	458	708	180	
		300	SATM10030	3.978	508	808	180	
140	1.380	50	SATM14005	1.005	282	332	225	
		100	SATM14010	2.011	332	432	225	
		150	SATM14015	3.016	382	532	225	
		200	SATM14020	4.021	432	632	225	
		250	SATM14025	5.027	482	732	225	
		300	SATM14030	6.032	532	832	225	
200	1.946	50	SATM20005	1.418	296	346	265	
		100	SATM20010	2.835	346	446	265	
		150	SATM20015	4.253	396	546	265	
		200	SATM20020	5.670	446	646	265	
		250	SATM20025	7.088	496	746	265	
		300	SATM20030	8.506	546	846	265	



OPTIONAL TILTING SADDLES

Model	L	N	Weight
LARZEP	mm	mm	kg
AZ0401	45	36	0,4
AZ0402	61	39	0,8
AZ0404	88	47	2,2
AZ0405	111	52	4,0

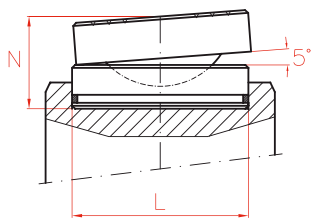

P.118

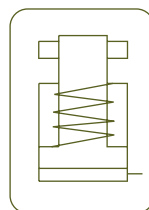

Type **SATM**

Capacity **30 - 200 Tn**

Stroke **50 - 300 mm**

Max. pressure **700 bar**

	E	F	H	J	K	L	N	R	S	T	U	Area	Weight	Model	With tilting saddle	
	mm	mm	mm	mm	mm	mm	mm		mm	mm	mm	cm <sup>2</sup>	kg	LARZEP	A	Model
	75	Tr 60x4	24	35	3	45	11	M6	85	19	95	44	4,9	SATM03005	229	AZ0401
	75	Tr 60x4	24	35	3	45	11	M6	85	19	95	44	5,9	SATM03010	279	AZ0401
	75	Tr 60x4	24	35	3	45	11	M6	85	19	95	44	7,0	SATM03015	329	AZ0401
	75	Tr 60x4	24	35	3	45	11	M6	85	19	95	44	7,9	SATM03020	376	AZ0401
	75	Tr 60x4	24	35	3	45	11	M6	85	19	95	44	8,9	SATM03025	429	AZ0401
	75	Tr 60x4	24	35	3	45	11	M6	85	19	95	44	9,8	SATM03030	479	AZ0401
	95	Tr 80x4	26	40	3	61	12	M6	115	19	125	71	9,4	SATM05005	243	AZ0402
	95	Tr 80x4	26	40	3	61	12	M6	115	19	125	71	11,1	SATM05010	293	AZ0402
	95	Tr 80x4	26	40	3	61	12	M6	115	19	125	71	12,8	SATM05015	343	AZ0402
	95	Tr 80x4	26	40	3	61	12	M6	115	19	125	71	14,6	SATM05020	393	AZ0402
	95	Tr 80x4	26	40	3	61	12	M6	115	19	125	71	16,3	SATM05025	443	AZ0402
	95	Tr 80x4	26	40	3	61	12	M6	115	19	125	71	18,0	SATM05030	493	AZ0402
	130	Tr 110x4	32	50	3	88	14	M6	160	19	170	133	18,0	SATM10005	291	AZ0404
	130	Tr 110x4	32	50	3	88	14	M6	160	19	170	133	21,0	SATM10010	341	AZ0404
	130	Tr 110x4	32	50	3	88	14	M6	160	19	170	133	24,1	SATM10015	391	AZ0404
	130	Tr 110x4	32	50	3	88	14	M6	160	19	170	133	27,1	SATM10020	441	AZ0404
	130	Tr 110x4	32	50	3	88	14	M6	160	19	170	133	30,1	SATM10025	491	AZ0404
	130	Tr 110x4	32	50	3	88	14	M6	160	19	170	133	33,2	SATM10030	541	AZ0404
	160	Tr 140x6	43	60	3	88	14	M6	200	19	210	201	32,6	SATM14005	315	AZ0404
	160	Tr 140x6	43	60	3	88	14	M6	200	19	210	201	37,5	SATM14010	365	AZ0404
	160	Tr 140x6	43	60	3	88	14	M6	200	19	210	201	42,4	SATM14015	415	AZ0404
	160	Tr 140x6	43	60	3	88	14	M6	200	19	210	201	47,4	SATM14020	465	AZ0404
	160	Tr 140x6	43	60	3	88	14	M6	200	19	210	201	52,3	SATM14025	515	AZ0404
	160	Tr 140x6	43	60	3	88	14	M6	200	19	210	201	57,2	SATM14030	565	AZ0404
	190	Tr 170x6	51	65	3	111	15	M6	225	19	250	284	52,7	SATM20005	333	AZ0405
	190	Tr 170x6	51	65	3	111	15	M6	225	19	250	284	58,6	SATM20010	383	AZ0405
	190	Tr 170x6	51	65	3	111	15	M6	225	19	250	284	64,5	SATM20015	433	AZ0405
	190	Tr 170x6	51	65	3	111	15	M6	225	19	250	284	70,5	SATM20020	483	AZ0405
	190	Tr 170x6	51	65	3	111	15	M6	225	19	250	284	76,4	SATM20025	533	AZ0405
	190	Tr 170x6	51	65	3	111	15	M6	225	19	250	284	82,3	SATM20030	583	AZ0405

**SINGLE ACTING PANCAKE CYLINDERS, LOCK NUT, TILTING SADDLE, LOAD RETURN**

- ✓ Capacity from 50 to 1.100 Tn, stroke up to 50 mm.
- ✓ Load return. Lock nut tested under 50% overload.
- ✓ The lock nut holds the load mechanically for extended periods of time.
- ✓ Hydraulic end of stroke overflow port. Without stop ring.
- ✓ Built-in tilting saddle to improve side load resistance.
- ✓ Special coating as standard to improve corrosion and side load resistance.
- ✓ Used in confined spaces.

**STR**  
Single Acting Lock Nut Cylinders



P.32

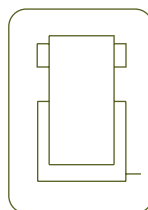

**S/A LOCK NUT CYLINDERS**



Type **STX**

Capacity **50 - 1.100 Tn**

Stroke **45 - 50 mm**

Max. pressure **700 bar**

STX CYLINDERS

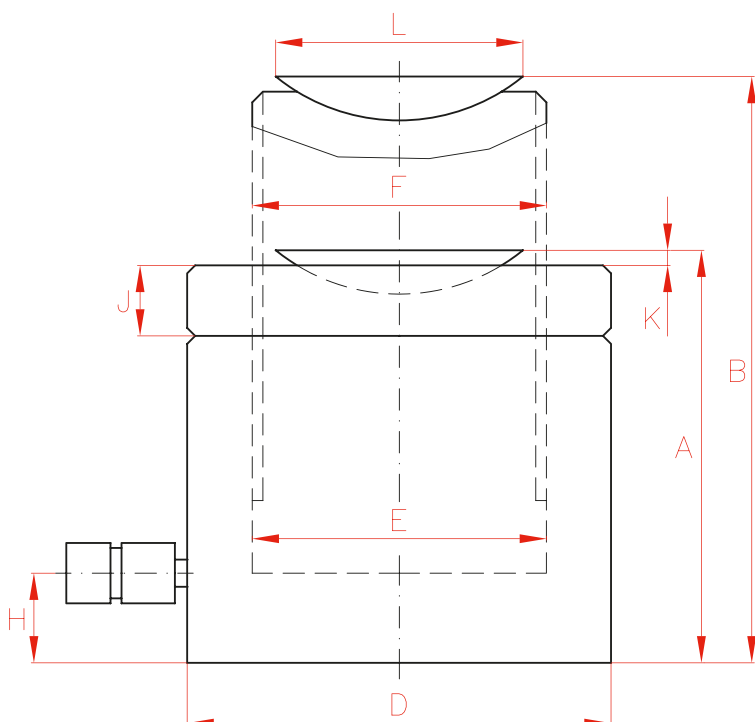

**STX**  
Built-in Tilting Saddle



P.46

**SX - SMX**  
Single Acting Low Profile Cylinders,  
Load or Spring Return



P.28

Capacity		Stroke	Model	Oil Cap.	A	B	D	E	F	H	J	K	L	Area	Weight
Tn	kN	mm	LARZEP	cm <sup>3</sup>	mm	mm	mm	mm	mm	mm	mm	mm	mm	cm <sup>2</sup>	kg
<b>50</b>	<b>486</b>	50	<b>STX05005</b>	355	125	175	120	95	Tr 95x4	19	21	6	92	71	11
<b>90</b>	<b>911</b>	45	<b>STX09004</b>	597	137	182	165	130	Tr 130x6	21	31	8	126	133	22
<b>140</b>	<b>1.380</b>	45	<b>STX14004</b>	905	148	193	200	160	Tr 160x6	27	38	9	148	201	39
<b>220</b>	<b>2.156</b>	45	<b>STX22004</b>	1.413	155	200	255	200	Tr 200x6	28	40	10	157	314	62
<b>350</b>	<b>3.468</b>	45	<b>STX35004</b>	2.208	178	223	310	250	Tr 250x6	35	50	11	240	491	111
<b>430</b>	<b>4.227</b>	45	<b>STX43004</b>	2.771	184	229	340	280	Tr 280x6	35	55	10	260	616	126
<b>550</b>	<b>5.520</b>	45	<b>STX56004</b>	3.618	192	237	390	320	Tr 320x6	38	60	10	295	804	193
<b>670</b>	<b>6.600</b>	45	<b>STX67004</b>	4.330	236	281	430	350	Tr 350x6	50	75	15	295	962	259
<b>880</b>	<b>8.620</b>	45	<b>STX88004</b>	5.655	268	313	490	400	Tr 400x6	60	85	20	325	1.257	482
<b>1.100</b>	<b>10.905</b>	45	<b>STX110004</b>	7.157	295	340	550	450	Tr 450x6	65	95	25	400	1.590	532

**SINGLE ACTING TELESCOPIC CYLINDERS**



- ✓ Capacity from 10 to 30 Tn, stroke up to 600 mm.
- ✓ For applications with minimum clearance and high lift required.
- ✓ Load return.
- ✓ With tilting saddle to improve side load resistance. Flat saddle available as option for confined spaces.
- ✓ Special coating as standard to improve corrosion and side load resistance.
- ✓ Double acting steel DL, aluminium double acting DLA and aluminium single acting SLA available as special.

Capacity	Model	1 <sup>st</sup> Stage			2 <sup>nd</sup> Stage			
		LARZEP	Capacity	Stroke	Area	Capacity	Stroke	
Tn		kN	mm	cm <sup>2</sup>	kN	mm	cm <sup>2</sup>	
15	SL01427	345	135	50,3	135	270	19,6	
	SL01643	911	145	132,7	389	290	56,7	
20	SL02030	486	150	70,8	194	300	28,2	
	SL02050	1.213	170	176,7	486	340	70,8	
30	SL03130	776	150	113	303	300	44,1	
	SL03160	1.947	200	283,5	776	400	113	





TELESCOPIC CYLINDERS



Special Double Acting Aluminium Cylinders DLA.

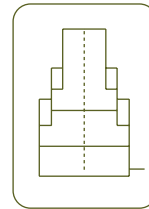

Type	<b>SL</b>
Capacity	<b>15 - 30 Tn</b>
Stroke	<b>270 - 600 mm</b>
Max. pressure	<b>700 bar</b>

SL CYLINDERS



Double Acting Telescopic Cylinders DL.

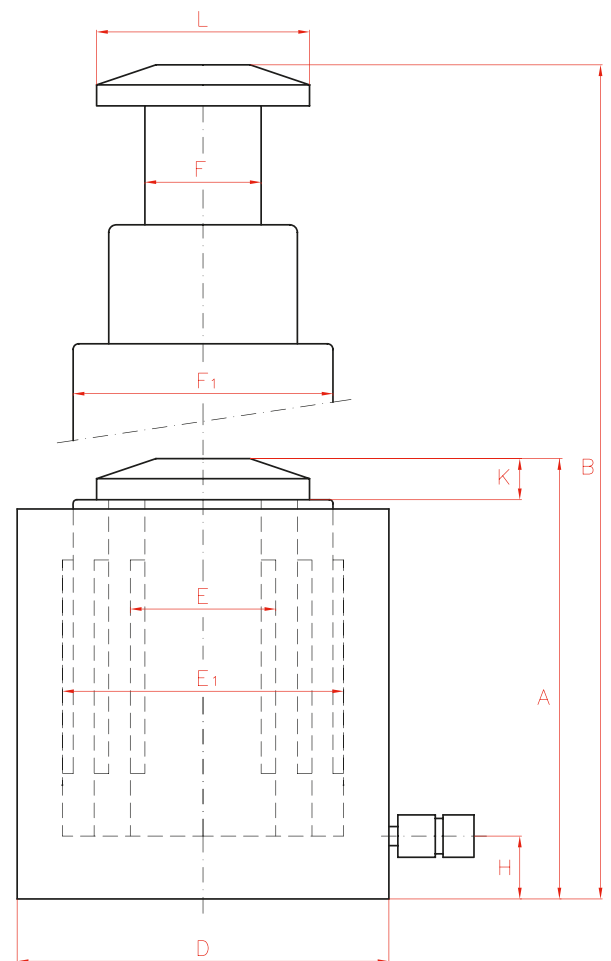

	3 <sup>rd</sup> Stage			Model	Oil Cap.	A	B	D	E	E1	F	F1	H	K	L	Weight	
	Capacity	Stroke	Area														LARZEP
	kN	mm	cm <sup>2</sup>														
-	-	-	<b>SL01427</b>	944	269	539	110	50	80	40	68	20	35	45	16		
163	435	23,7	<b>SL01643</b>	3.092	310	745	170	50	130	45	110	27	38	45	40		
-	-	-	<b>SL02030</b>	1.487	299	599	125	50	80	60	95	23	35	45	22		
194	500	28,2	<b>SL02050</b>	4.661	351	851	200	50	125	60	150	34	39	61	66		
-	-	-	<b>SL03130</b>	2.359	324	644	160	60	100	75	120	25	38	61	40		
303	600	44,1	<b>SL03160</b>	8.816	405	1.005	250	65	160	75	190	44	40	61	120		

**SINGLE ACTING HIGH TONNAGE CYLINDERS, LOAD RETURN**

- ✓ Capacity from 140 to 1.100 Tn, stroke up to 300 mm.
- ✓ Load return. For weighing, lifting and positioning applications in Civil Engineering.
- ✓ Hydraulic end of stroke overflow port. Without stop ring.  
For mechanical stop ring see SPR models.
- ✓ For confined spaces and loads up to 150 Tn, see SX and SP models.

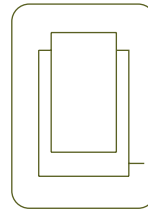

**S/A LOAD RETURN CYLINDERS**



Type	<b>SSR</b>
Capacity	140 - 1.100 Tn
Stroke	50 - 300 mm
Max. pressure	700 bar

**SPR**  
S/A Low Height Cylinders, High Tonnage, Load Return



P.24

**DDR**  
Double Acting High Tonnage Cylinders



P.60

**HBM / HBE**  
Powerpack



P.88

SSR CYLINDERS



Larzep designs and manufactures special cylinders up to 1.100 Tn capacity to place load cells for pile testing applications.

**OPTIONAL TILTING SADDLES**

Model	L	N	Weight
LARZEP	mm	mm	kg
AZ0404	88	47	2,2
AZ0405	111	52	4,0
AZ0408	178	67	13,0
AZ0411	200	79	19,3
AZ0413	250	105	40,0
AZ0415	325	175	113,0

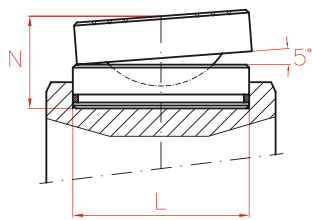

P.118

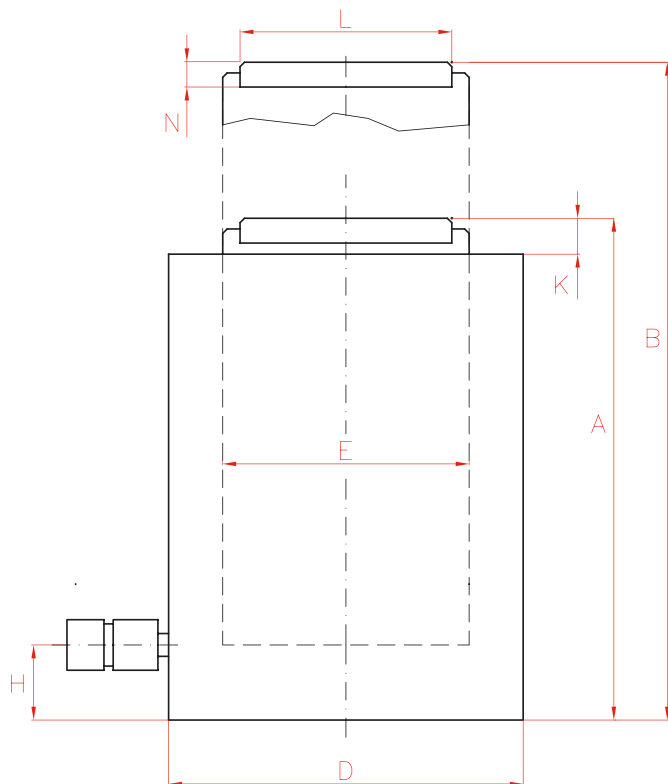

Capacity		Stroke	Model	Oil Cap.	A	
Tn	kN	mm	LARZEP	cm <sup>3</sup>	mm	
140	1.380	50	SSR14005	1.005	155	
		100	SSR14010	2.011	205	
		150	SSR14015	3.016	255	
		200	SSR14020	4.021	305	
		250	SSR14025	5.027	355	
		300	SSR14030	6.032	405	
220	2.156	50	SSR22005	1.571	170	
		100	SSR22010	3.142	220	
		150	SSR22015	4.712	270	
		200	SSR22020	6.283	320	
		250	SSR22025	7.854	370	
		300	SSR22030	9.425	420	
350	3.369	50	SSR35005	2.454	210	
		100	SSR35010	4.909	260	
		150	SSR35015	7.363	310	
		200	SSR35020	9.817	360	
		250	SSR35025	12.272	410	
		300	SSR35030	14.726	460	
430	4.224	50	SSR43005	3.079	215	
		100	SSR43010	6.158	265	
		150	SSR43015	9.236	315	
		200	SSR43020	12.315	365	
		250	SSR43025	15.394	415	
		300	SSR43030	18.473	465	
560	5.520	50	SSR56005	4.021	240	
		100	SSR56010	8.042	290	
		150	SSR56015	12.064	340	
		200	SSR56020	16.085	390	
		250	SSR56025	20.106	440	
		300	SSR56030	24.127	490	
670	6.600	50	SSR67005	4.811	260	
		100	SSR67010	9.621	315	
		150	SSR67015	14.432	365	
		200	SSR67020	19.242	415	
		250	SSR67025	24.053	465	
		300	SSR67030	28.863	515	
880	8.625	50	SSR88005	6.283	290	
		100	SSR88010	12.566	340	
		150	SSR88015	18.850	390	
		200	SSR88020	25.133	440	
		250	SSR88025	31.416	490	
		300	SSR88030	37.699	540	
1.100	10.916	50	SSR110005	7.952	340	
		100	SSR110010	15.904	390	
		150	SSR110015	23.856	440	
		200	SSR110020	31.809	490	
		250	SSR110025	39.761	540	
		300	SSR110030	47.713	590	



	B	D	E	H	K	L	N	Area	Weight	Model	With tilting saddle	
	mm	mm	mm	mm	mm	mm	mm	cm <sup>2</sup>	kg	LARZEP	A	Model
	205	200	160	30	7	88	14	201	38	SSR14005	187	AZ0404
	305	200	160	30	7	88	14	201	51	SSR14010	237	AZ0404
	405	200	160	30	7	88	14	201	63	SSR14015	287	AZ0404
	505	200	160	30	7	88	14	201	75	SSR14020	337	AZ0404
	605	200	160	30	7	88	14	201	88	SSR14025	387	AZ0404
	705	200	160	30	7	88	14	201	100	SSR14030	437	AZ0404
	220	250	200	40	7	111	15	314	64	SSR22005	207	AZ0405
	320	250	200	40	7	111	15	314	85	SSR22010	257	AZ0405
	420	250	200	40	7	111	15	314	104	SSR22015	307	AZ0405
	520	250	200	40	7	111	15	314	123	SSR22020	357	AZ0405
	620	250	200	40	7	111	15	314	143	SSR22025	407	AZ0405
	720	250	200	40	7	111	15	314	162	SSR22030	457	AZ0405
	260	310	250	50	7	178	23	491	123	SSR35005	254	AZ0408
	360	310	250	50	7	178	23	491	154	SSR35010	304	AZ0408
	460	310	250	50	7	178	23	491	184	SSR35015	354	AZ0408
	560	310	250	50	7	178	23	491	213	SSR35020	404	AZ0408
	660	310	250	50	7	178	23	491	243	SSR35025	454	AZ0408
	760	310	250	50	7	178	23	491	273	SSR35030	504	AZ0408
	265	340	280	55	7	178	23	616	151	SSR43005	259	AZ0408
	365	340	280	55	7	178	23	616	189	SSR43010	309	AZ0408
	465	340	280	55	7	178	23	616	225	SSR43015	359	AZ0408
	565	340	280	55	7	178	23	616	260	SSR43020	409	AZ0408
	665	340	280	55	7	178	23	616	296	SSR43025	459	AZ0408
	765	340	280	55	7	178	23	616	331	SSR43030	509	AZ0408
	290	390	320	60	7	200	27	804	223	SSR56005	292	AZ0411
	390	390	320	60	7	200	27	804	272	SSR56010	342	AZ0411
	490	390	320	60	7	200	27	804	319	SSR56015	392	AZ0411
	590	390	320	60	7	200	27	804	366	SSR56020	442	AZ0411
	690	390	320	60	7	200	27	804	413	SSR56025	492	AZ0411
	790	390	320	60	7	200	27	804	459	SSR56030	542	AZ0411
	310	430	350	65	7	200	27	962	294	SSR67005	312	AZ0411
	415	430	350	65	7	200	27	962	353	SSR67010	367	AZ0411
	515	430	350	65	7	200	27	962	416	SSR67015	417	AZ0411
	615	430	350	65	7	200	27	962	473	SSR67020	467	AZ0411
	715	430	350	65	7	200	27	962	530	SSR67025	517	AZ0411
	815	430	350	65	7	200	27	962	587	SSR67030	567	AZ0411
	340	490	400	70	10	250	35	1.257	423	SSR88005	360	AZ0413
	440	490	400	70	10	250	35	1.257	503	SSR88010	410	AZ0413
	540	490	400	70	10	250	35	1.257	577	SSR88015	460	AZ0413
	640	490	400	70	10	250	35	1.257	651	SSR88020	510	AZ0413
	740	490	400	70	10	250	35	1.257	725	SSR88025	560	AZ0413
	840	490	400	70	10	250	35	1.257	799	SSR88030	610	AZ0413
	390	550	450	80	10	325	55	1.590	622	SSR110005	460	AZ0415
	490	550	450	80	10	325	55	1.590	716	SSR110010	510	AZ0415
	590	550	450	80	10	325	55	1.590	810	SSR110015	560	AZ0415
	690	550	450	80	10	325	55	1.590	903	SSR110020	610	AZ0415
	790	550	450	80	10	325	55	1.590	996	SSR110025	660	AZ0415
	890	550	450	80	10	325	55	1.590	1.090	SSR110030	710	AZ0415



**PULL CYLINDERS**



- ✓ Capacity from 5 to 50 Tn, stroke up to 150 mm.
- ✓ T and TE models are Spring Return.
- ✓ TD models are Double Acting.
- ✓ For pulling applications: to hook and join plates for welding, tensioning cables, etc.



Capacity		Stroke	Model	Oil Cap.	A
Tn	kN	mm	LARZEP	cm <sup>3</sup>	mm
5	54	140	T00514/5G	110	306
		140	T00514/10G	110	306
10	93	140	T01015	190	308
		150	TE01015	204	576
30	302	150	TD01015	356	576
		150	TE03015	660	723
50	483	150	TD03015	954	723
		150	TE05015	1.056	757
		150	TD05015	1.425	757



PULL CYLINDERS



Type	<b>T - TE - TD</b>
Capacity	<b>5 - 50 Tn</b>
Stroke	<b>140 - 150 mm</b>
Max. pressure	<b>700 bar</b>

T - TE - TD CYLINDERS

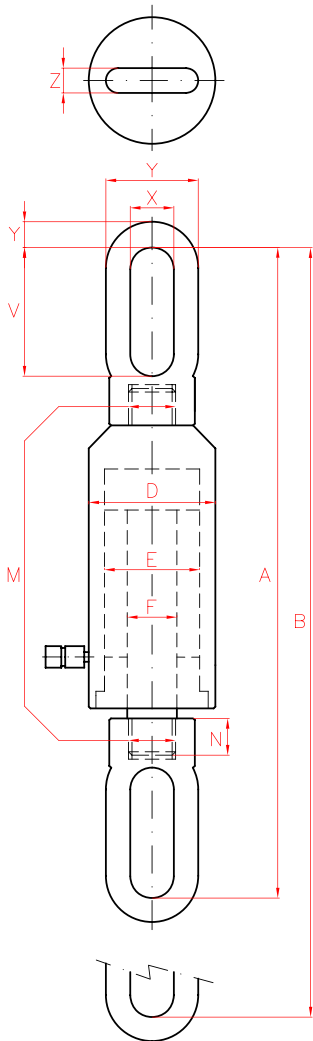

TE

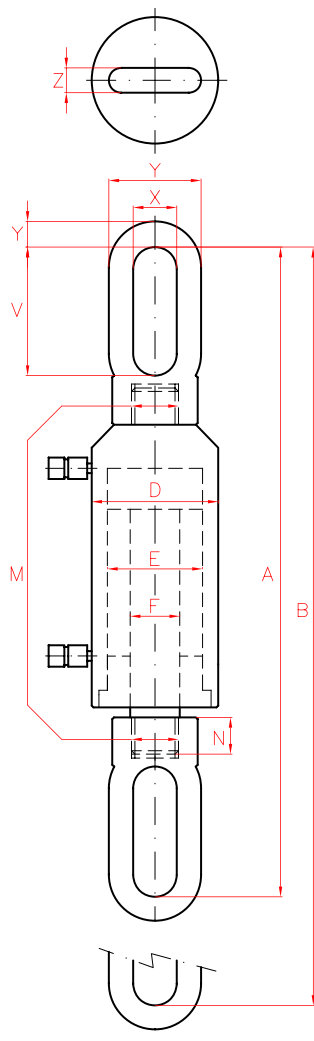

TD

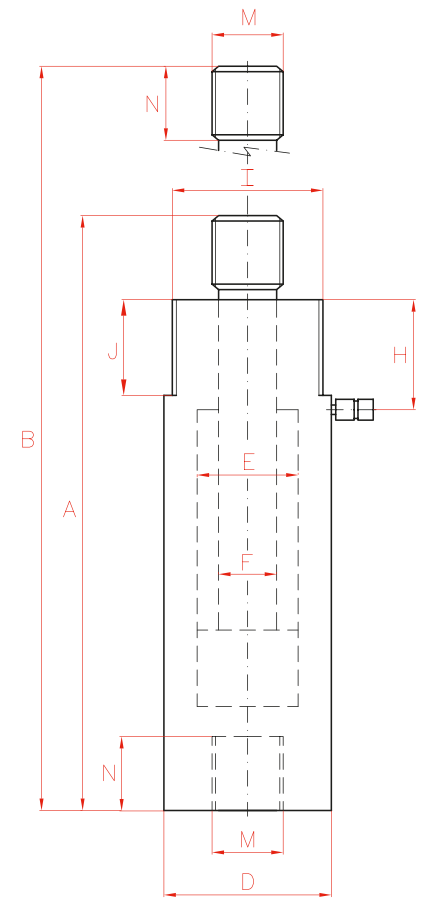

T

	B	D	E	F	M	N	I	J	H	U	V	X	Y	Z	Area	Weight	Model
	mm	mm	mm	mm		mm	UN	mm	mm	mm	mm	mm	mm	mm	cm <sup>2</sup>	kg	LARZEP
	446	60	45	32	3/4" BSP	25	2 1/4" UNS	25	46	-	-	-	-	-	7,9	6,7	<b>T00514/5G</b>
	446	60	45	32	1 1/4" BSP	25	2 1/4" UNS	25	46	-	-	-	-	-	7,9	6,7	<b>T00514/10G</b>
	448	85	55	36	1 3/4" BSP	30	3 5/16" UNS	40	55	-	-	-	-	-	13,6	10,0	<b>T01015</b>
	726	86	55	36	M30x2	25	-	-	-	107	109	46	30,5	30,5	13,5	14,9	<b>TE01015</b>
	726	86	55	36	M30x2	25	-	-	-	107	109	46	30,5	30,5	13,5	14,9	<b>TD01015</b>
	873	125	90	50	M40x2	45	-	-	-	108	153	50	29	29	43,9	32,0	<b>TE03015</b>
	873	125	90	50	M40x2	45	-	-	-	108	153	50	29	29	43,9	32,0	<b>TD03015</b>
	907	148	110	56	M52x2	60	-	-	-	130	150	50	70	39	70,3	60,0	<b>TE05015</b>
	907	148	110	56	M52x2	60	-	-	-	130	150	50	70	39	70,3	60,0	<b>TD05015</b>

## DOUBLE ACTING CYLINDERS



- ✓ Capacity from 10 to 550 Tn, stroke up to 320 mm as standard.
- ✓ For push and pull applications.
- ✓ For heavy duty applications, high precision and involving high cycle life.
- ✓ Guide and sealing system of highest quality.
- ✓ Safety valve to prevent accidental over-pressure.
- ✓ Collar threads, piston end threads and base mounting holes for easy fixing and pull operations.
- ✓ Compatible with SM accessories.
- ✓ Longer stroke models up to 1.500 mm upon request.

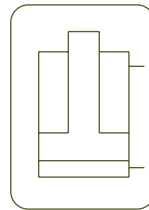

**DOUBLE ACTING CYLINDERS**



Type	<b>D</b>
Capacity	10 - 550 Tn
Stroke	50 - 320 mm
Max. pressure	700 bar

**DDR**  
Double Acting High Tonnage Cylinders



P.60

**DDA**  
Double Acting Aluminium Cylinders



P.64

**SM & D**  
Special attachments for SM and D models



P.10

**AZ04**  
Optional Tilting Saddles available



P.118



**HBM / HBE**  
Powerpack



P.88

**Z22107**  
Air Hydraulic Pump



P.86

**X**  
Double Acting Hand Pumps



P.80

**Models from 50 to 550 Tn**

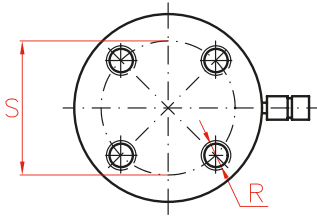

**Models up to 30 Tn**

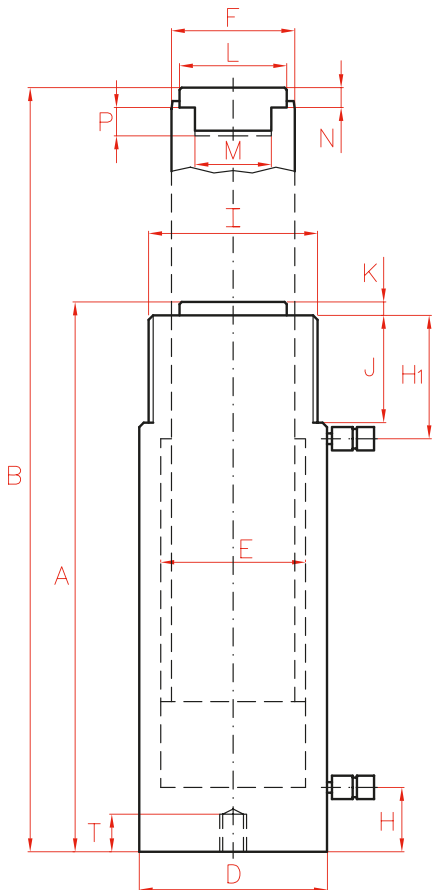
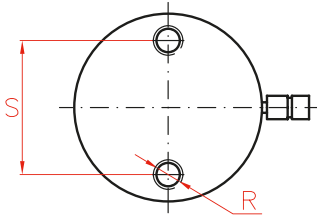

Capacity Tn	Stroke mm	Model LARZEP	Capacity (kN)		Oil Cap. cm <sup>3</sup>	A mm	B mm	D mm	E mm	F mm
			Push	Pull						
10	160	D01016	109	20	255	310	470	60	45	36
	250	D01025	109	20	398	400	650	60	45	36
	320	D01032	109	20	509	470	790	60	45	36
20	160	D02016	214	53	499	320	480	83	63	45
	250	D02025	214	53	779	410	660	83	63	45
	320	D02032	214	53	997	480	800	83	63	45
30	160	D03016	303	68	707	335	495	100	75	56
	320	D03032	303	68	1.413	495	815	100	75	56
50	160	D05016	486	72	1.134	335	495	127	95	80
	320	D05032	486	72	2.267	510	830	127	95	80
75	160	D07516	712	140	1.661	338	498	150	115	90
	320	D07532	712	140	3.322	512	832	150	115	90
100	160	D10016	911	189	2.123	339	499	177	130	100
	320	D10032	911	189	4.245	509	829	177	130	100
150	50	D15005	1.380	370	1.005	258	308	215	160	110
	150	D15015	1.380	370	3.015	378	528	215	160	110
	300	D15030	1.380	370	6.029	528	828	215	160	110
200	50	D20005	2.156	560	1.570	274	324	265	200	140
	150	D20015	2.156	560	4.710	394	544	265	200	140
	300	D20030	2.156	560	9.420	544	844	265	200	140
350	50	D35005	3.368	1.014	2.454	299	349	330	250	160
	150	D35015	3.368	1.014	7.359	419	569	330	250	160
	300	D35030	3.368	1.014	14.718	569	869	330	250	160
550	50	D55005	5.519	1.714	4.020	383	433	430	320	200
	150	D55015	5.519	1.714	12.058	518	668	430	320	200
	300	D55030	5.519	1.714	24.116	668	968	430	320	200





OPTIONAL TILTING SADDLES

Model	L	M	N	E	Weight
LARZEP	mm	UN	mm	mm	kg
AZ0420	28	1"-8	29	43	0,2
AZ0423	35	1"-8	29	49	0,3
AZ0421	45	1 1/2"-16	28	50	0,4
AZ0422	61	1 3/4"-12	38	58	0,7
AZ0424	88	2 1/2"-12	47	82	2,5
AZ0425	111	2 1/2"-12	52	107	4,5

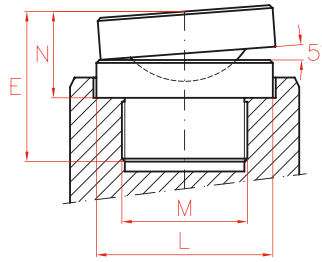

P.118

DOUBLE ACTING CYLINDERS



Type	<b>D</b>
Capacity	<b>10 - 550 Tn</b>
Stroke	<b>50 - 320 mm</b>
Max. pressure	<b>700 bar</b>

H	H1	I	J	K	L	M	N	P	R	S	T	Area	Weight	Model	With tilting saddle	
mm	mm	UN	mm	mm	mm	UN	mm	mm	UN	mm	mm	cm <sup>2</sup>	kg	LARZEP	A	Model
20	53,5	2 1/4"-14	32	7	28	1"-8	10	24	5/16"-18	39	12	16	6,4	D01016	329	AZ0420
20	53,5	2 1/4"-14	32	7	28	1"-8	10	24	5/16"-18	39	12	16	8,0	D01025	419	AZ0420
20	53,5	2 1/4"-14	32	7	28	1"-8	10	24	5/16"-18	39	12	16	9,5	D01032	489	AZ0420
20	60	3 1/4"-12	40	8	35	1"-8	8	24	1/2"-13	58	15	31	11,7	D02016	341	AZ0423
20	60	3 1/4"-12	40	8	35	1"-8	8	24	1/2"-13	58	15	31	14,5	D02025	431	AZ0423
20	60	3 1/4"-12	40	8	35	1"-8	8	24	1/2"-13	58	15	31	16,8	D02032	501	AZ0423
26	77	3 7/8"-12	48	10	45	1 1/2"-16	10	25	1/2"-13	66	15	44	18,9	D03016	353	AZ0421
26	77	3 7/8"-12	48	10	45	1 1/2"-16	10	25	1/2"-13	66	15	44	26,6	D03032	513	AZ0421
28	70	5"-12	50	10	61	1 3/4"-12	10	25	1/2"-13	95	15	71	30,8	D05016	363	AZ0422
28	85	5"-12	50	10	61	1 3/4"-12	10	25	1/2"-13	95	15	71	44,8	D05032	538	AZ0422
30	70	5 3/4"-12	50	10	61	1 3/4"-12	10	25	1/2"-13	100	18	104	42,0	D07516	366	AZ0422
30	80	5 3/4"-12	50	10	61	1 3/4"-12	10	25	1/2"-13	100	18	104	60,6	D07532	540	AZ0422
38	70	6 7/8"-12	50	10	88	1 3/4"-12	16	30	3/4"-10	139	18	133	51,8	D10016	361	AZ0422
38	84	6 7/8"-12	50	10	88	1 3/4"-12	16	30	3/4"-10	139	18	133	84,1	D10032	531	AZ0422
49	85	8"-12	55	10	88	2 1/2"-12	15	40	3/4"-16	158	25	201	66,0	D15005	279	AZ0424
49	85	8"-12	55	10	88	2 1/2"-12	15	40	3/4"-16	158	25	201	90,0	D15015	410	AZ0424
49	85	8"-12	55	10	88	2 1/2"-12	15	40	3/4"-16	158	25	201	119,0	D15030	560	AZ0424
65	85	9 3/4"-12	55	10	111	2 1/2"-12	19	60	1"-8	127	25	314	105,0	D20005	307	AZ0425
65	85	9 3/4"-12	55	10	111	2 1/2"-12	19	60	1"-8	127	25	314	151,0	D20015	427	AZ0425
65	85	9 3/4"-12	55	10	111	2 1/2"-12	19	60	1"-8	127	25	314	191,0	D20030	577	AZ0425
85	90	12 1/4"-12	60	10	131	3"-12	15	70	1 1/4"-7	158	40	491	189,0	D35005	-	-
85	90	12 1/4"-12	60	10	131	3"-12	15	70	1 1/4"-7	158	40	491	247,0	D35015	-	-
85	90	12 1/4"-12	60	10	131	3"-12	15	70	1 1/4"-7	158	40	491	346,0	D35030	-	-
110	120	15 5/8"-8	80	15	178	4"-12	26	85	1 3/4"-5	203	55	804	396,0	D55005	-	-
110	120	15 5/8"-8	80	15	178	4"-12	26	85	1 3/4"-5	203	55	804	504,0	D55015	-	-
110	120	15 5/8"-8	80	15	178	4"-12	26	85	1 3/4"-5	203	55	804	625,0	D55030	-	-

**DOUBLE ACTING HIGH TONNAGE CYLINDERS**



- ✓ Capacity from 50 to 1.100 Tn, stroke up to 300 mm.
- ✓ For harsh conditions in both vertical and horizontal positions.
- ✓ Safety valve to prevent accidental over-pressure.
- ✓ On request, DDR cylinders can be supplied with threads or other special features such as lock nuts, sleeves, etc.
- ✓ Models available up to 2.000 Tn lifting capacity per cylinder.

Capacity	Stroke	Model	Capacity (kN)	
Tn	mm	LARZEP	Push	
50	50	DDR05005	486	
	100	DDR05010	486	
	150	DDR05015	486	
	200	DDR05020	486	
	250	DDR05025	486	
	300	DDR05030	486	
100	50	DDR10005	911	
	100	DDR10010	911	
	150	DDR10015	911	
	200	DDR10020	911	
	250	DDR10025	911	
	300	DDR10030	911	
140	50	DDR14005	1.380	
	100	DDR14010	1.380	
	150	DDR14015	1.380	
	200	DDR14020	1.380	
	250	DDR14025	1.380	
	300	DDR14030	1.380	



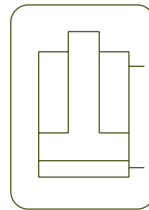
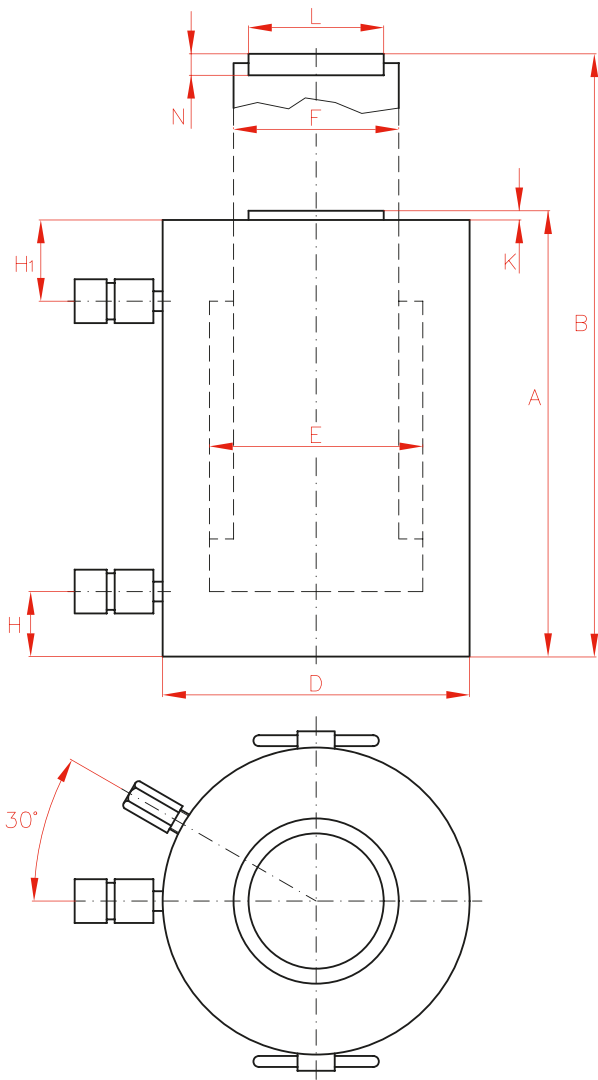

D/A HIGH TONNAGE CYLINDERS



Type	<b>DDR</b>
Capacity	<b>50 - 1.100 Tn</b>
Stroke	<b>50 - 300 mm</b>
Max. pressure	<b>700 bar</b>

**DDA**  
Aluminium Double Acting Cylinders



P.64

	Oil Cap.	A	B	D	E	F	H	H1	K	L	N	Area	Weight	Model	With tilting saddle	
	cm <sup>3</sup>	mm	mm	mm	mm	mm	mm	mm	mm	mm	mm	cm <sup>2</sup>	kg	LARZEP	A	Model
	354	216	266	127	95	80	30	80	6	61	12	71	20	<b>DDR05005</b>	243	AZ0402
	709	266	366	127	95	80	30	80	6	61	12	71	24	<b>DDR05010</b>	293	AZ0402
	1.063	316	466	127	95	80	30	80	6	61	12	71	28	<b>DDR05015</b>	343	AZ0402
	1.418	366	566	127	95	80	30	80	6	61	12	71	32	<b>DDR05020</b>	393	AZ0402
	1.772	416	666	127	95	80	30	80	6	61	12	71	36	<b>DDR05025</b>	443	AZ0402
	2.126	466	766	127	95	80	30	80	6	61	12	71	40	<b>DDR05030</b>	493	AZ0402
	664	196	246	170	130	100	30	60	6	88	14	133	31	<b>DDR10005</b>	229	AZ0404
	1.327	246	346	170	130	100	30	60	6	88	14	133	39	<b>DDR10010</b>	279	AZ0404
	1.991	296	446	170	130	100	30	60	6	88	14	133	47	<b>DDR10015</b>	329	AZ0404
	2.655	346	546	170	130	100	30	60	6	88	14	133	56	<b>DDR10020</b>	379	AZ0404
	3.318	401	651	170	130	100	30	65	6	88	14	133	65	<b>DDR10025</b>	434	AZ0404
	3.982	451	751	170	130	100	30	65	6	88	14	133	72	<b>DDR10030</b>	484	AZ0404
	1.005	201	251	200	160	110	35	60	6	88	14	201	44	<b>DDR14005</b>	234	AZ0404
	2.011	251	351	200	160	110	35	60	6	88	14	201	51	<b>DDR14010</b>	284	AZ0404
	3.016	306	456	200	160	110	35	65	6	88	14	201	59	<b>DDR14015</b>	339	AZ0404
	4.021	356	556	200	160	110	35	65	6	88	14	201	66	<b>DDR14020</b>	389	AZ0404
	5.027	411	661	200	160	110	35	70	6	88	14	201	74	<b>DDR14025</b>	444	AZ0404
	6.032	461	761	200	160	110	35	70	6	88	14	201	81	<b>DDR14030</b>	494	AZ0404

**OPTIONAL TILTING SADDLES**

Model	L	N	Weight
LARZEP	mm	mm	kg
AZ0402	61	39	0,8
AZ0404	88	47	2,2
AZ0405	111	52	4,0
AZ0408	178	67	13,0
AZ0411	200	79	19,3
AZ0413	250	105	40,0
AZ0415	325	175	113,0

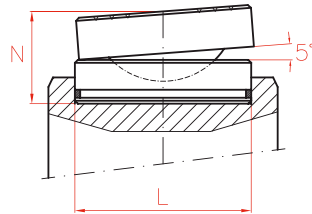

P.118

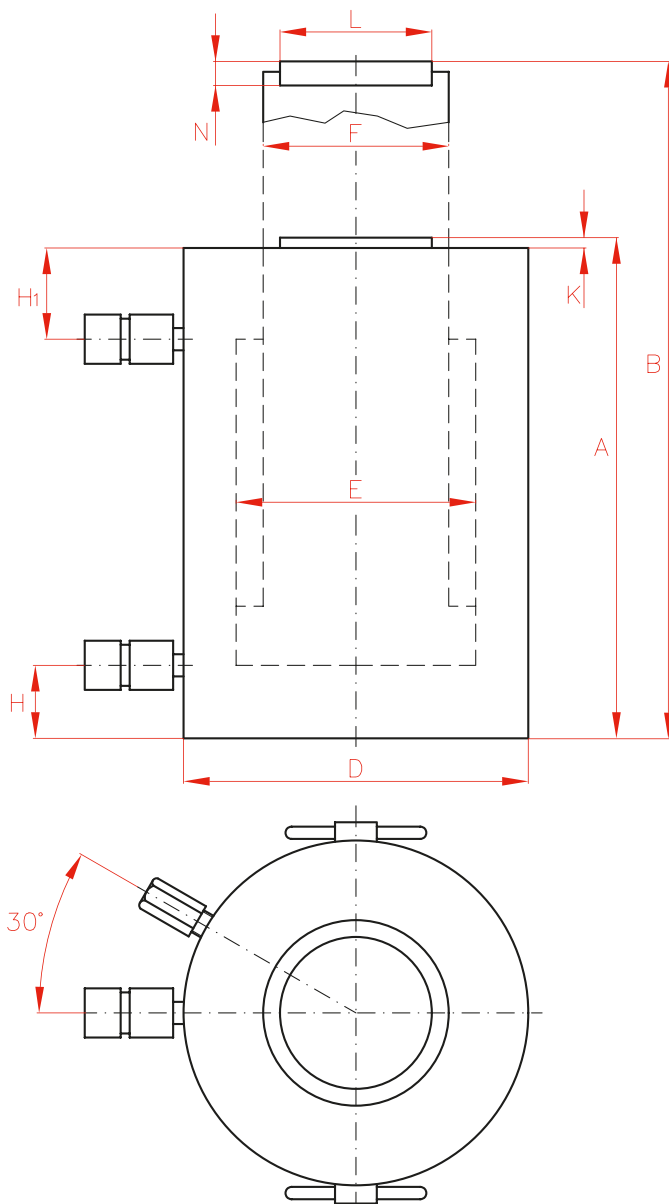

Capacity	Stroke	Model	Capacity (kN)	
			Tn	Push
	mm	LARZEP		
220	50	DDR22005	2.156	
	100	DDR22010	2.156	
	150	DDR22015	2.156	
	200	DDR22020	2.156	
	250	DDR22025	2.156	
	300	DDR22030	2.156	
350	50	DDR35005	3.370	
	100	DDR35010	3.370	
	150	DDR35015	3.370	
	200	DDR35020	3.370	
	250	DDR35025	3.370	
	300	DDR35030	3.370	
430	50	DDR43005	4.224	
	100	DDR43010	4.224	
	150	DDR43015	4.224	
	200	DDR43020	4.224	
	250	DDR43025	4.224	
	300	DDR43030	4.224	
560	50	DDR56005	5.521	
	100	DDR56010	5.521	
	150	DDR56015	5.521	
	200	DDR56020	5.521	
	250	DDR56025	5.521	
	300	DDR56030	5.521	
670	50	DDR67005	6.600	
	100	DDR67010	6.600	
	150	DDR67015	6.600	
	200	DDR67020	6.600	
	250	DDR67025	6.600	
	300	DDR67030	6.600	
880	50	DDR88005	8.626	
	100	DDR88010	8.626	
	150	DDR88015	8.626	
	200	DDR88020	8.626	
	250	DDR88025	8.626	
	300	DDR88030	8.626	
1.100	50	DDR110005	10.921	
	100	DDR110010	10.921	
	150	DDR110015	10.921	
	200	DDR110020	10.921	
	250	DDR110025	10.921	
	300	DDR110030	10.921	



	Oil Cap.	A	B	D	E	F	H	H1	K	L	N	Area	Weight	Model	With tilting saddle	
	cm <sup>3</sup>	mm	mm	mm	mm	mm	mm	mm	mm	mm	mm	cm <sup>2</sup>	kg	LARZEP	A	Model
	1.571	216	266	250	200	140	40	70	6	111	15	314	75	DDR22005	253	AZ0405
	3.142	266	366	250	200	140	40	70	6	111	15	314	86	DDR22010	303	AZ0405
	4.712	326	476	250	200	140	40	75	6	111	15	314	101	DDR22015	363	AZ0405
	6.283	376	576	250	200	140	40	75	6	111	15	314	112	DDR22020	413	AZ0405
	7.854	436	686	250	200	140	40	80	6	111	15	314	127	DDR22025	473	AZ0405
	9.425	486	786	250	200	140	40	80	6	111	15	314	139	DDR22030	523	AZ0405
	2.454	236	286	310	250	200	50	80	6	178	23	491	127	DDR35005	280	AZ0408
	4.909	286	386	310	250	200	50	80	6	178	23	491	148	DDR35010	330	AZ0408
	7.363	341	491	310	250	200	50	80	6	178	23	491	175	DDR35015	385	AZ0408
	9.817	391	591	310	250	200	50	80	6	178	23	491	195	DDR35020	435	AZ0408
	12.272	451	701	310	250	200	50	85	6	178	23	491	222	DDR35025	495	AZ0408
	14.726	501	801	310	250	200	50	85	6	178	23	491	243	DDR35030	545	AZ0408
	3.079	248	298	340	280	220	55	85	8	178	23	616	164	DDR43005	292	AZ0408
	6.158	298	398	340	280	220	55	85	8	178	23	616	188	DDR43010	342	AZ0408
	9.236	353	503	340	280	220	55	85	8	178	23	616	215	DDR43015	397	AZ0408
	12.315	403	603	340	280	220	55	85	8	178	23	616	239	DDR43020	447	AZ0408
	15.394	458	708	340	280	220	55	85	8	178	23	616	266	DDR43025	502	AZ0408
	18.473	508	808	340	280	220	55	85	8	178	23	616	290	DDR43030	552	AZ0408
	4.021	268	318	390	320	250	65	90	8	200	27	804	234	DDR56005	320	AZ0411
	8.042	318	418	390	320	250	65	90	8	200	27	804	266	DDR56010	370	AZ0411
	12.064	373	523	390	320	250	65	90	8	200	27	804	301	DDR56015	425	AZ0411
	16.085	423	623	390	320	250	65	90	8	200	27	804	332	DDR56020	475	AZ0411
	20.106	488	738	390	320	250	65	100	8	200	27	804	377	DDR56025	540	AZ0411
	24.127	538	838	390	320	250	65	100	8	200	27	804	408	DDR56030	590	AZ0411
	4.811	293	343	430	350	280	65	105	8	200	27	962	315	DDR67005	345	AZ0411
	9.621	343	443	430	350	280	65	105	8	200	27	962	355	DDR67010	395	AZ0411
	14.432	398	548	430	350	280	65	105	8	200	27	962	400	DDR67015	450	AZ0411
	19.242	448	648	430	350	280	65	105	8	200	27	962	439	DDR67020	500	AZ0411
	24.053	508	758	430	350	280	65	105	8	200	27	962	490	DDR67025	560	AZ0411
	28.863	558	858	430	350	280	65	105	8	200	27	962	530	DDR67030	610	AZ0411
	6.283	310	360	490	400	320	70	115	10	250	35	1.257	434	DDR88005	380	AZ0413
	12.566	360	460	490	400	320	70	115	10	250	35	1.257	485	DDR88010	430	AZ0413
	18.850	420	570	490	400	320	70	115	10	250	35	1.257	551	DDR88015	490	AZ0413
	25.133	470	670	490	400	320	70	115	10	250	35	1.257	602	DDR88020	540	AZ0413
	31.416	530	780	490	400	320	70	115	10	250	35	1.257	668	DDR88025	600	AZ0413
	37.699	580	880	490	400	320	70	115	10	250	35	1.257	719	DDR88030	650	AZ0413
	7.952	330	380	550	450	360	80	125	10	325	55	1.590	578	DDR110005	450	AZ0415
	15.904	380	480	550	450	360	80	125	10	325	55	1.590	648	DDR110010	500	AZ0415
	23.856	440	590	550	450	360	80	125	10	325	55	1.590	731	DDR110015	560	AZ0415
	31.809	490	690	550	450	360	80	125	10	325	55	1.590	795	DDR110020	610	AZ0415
	39.761	550	800	550	450	360	80	125	10	325	55	1.590	878	DDR110025	670	AZ0415
	47.713	600	900	550	450	360	80	125	10	325	55	1.590	960	DDR110030	720	AZ0415



## ALUMINIUM DOUBLE ACTING CYLINDERS



- ✓ Capacity from 50 to 200 Tn, stroke up to 300 mm.
- ✓ Made out of high strength aluminium alloy.
- ✓ All aluminium parts are treated to improve resistance and extend working life.
- ✓ Lightweight. Over 40% weight reduction when compared with steel equivalent.
- ✓ Fitted with steel base plate and saddle for wear resistance.
- ✓ Internal safety valve to prevent accidental over-pressure.
- ✓ Not suitable for high cycle applications.

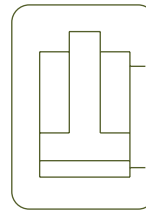

Larzep designs and manufactures special cylinders and fixing systems. For further information, please contact our Internal Sales department.



Step by step aluminium cylinders. Stage lifting.



**ALUM. DOUBLE ACTING CYLINDERS**



Type	<b>DDA</b>
Capacity	50 - 200 Tn
Stroke	50 - 300 mm
Max. pressure	700 bar

DDA CYLINDERS

**DDR**  
Double Acting High Tonnage Cylinders



P.60

**D**  
Double Acting Cylinders



P.56

**DAH**  
Aluminium Double Acting  
Hollow Piston Cylinders



P.70

**AZ04**  
Optional Tilting Saddles available



P.118

**HBM / HBE**  
Powerpack



P.88

**Z22107**  
Air Hydraulic Pump



P.86

**X**  
Double Acting Hand Pumps



P.80

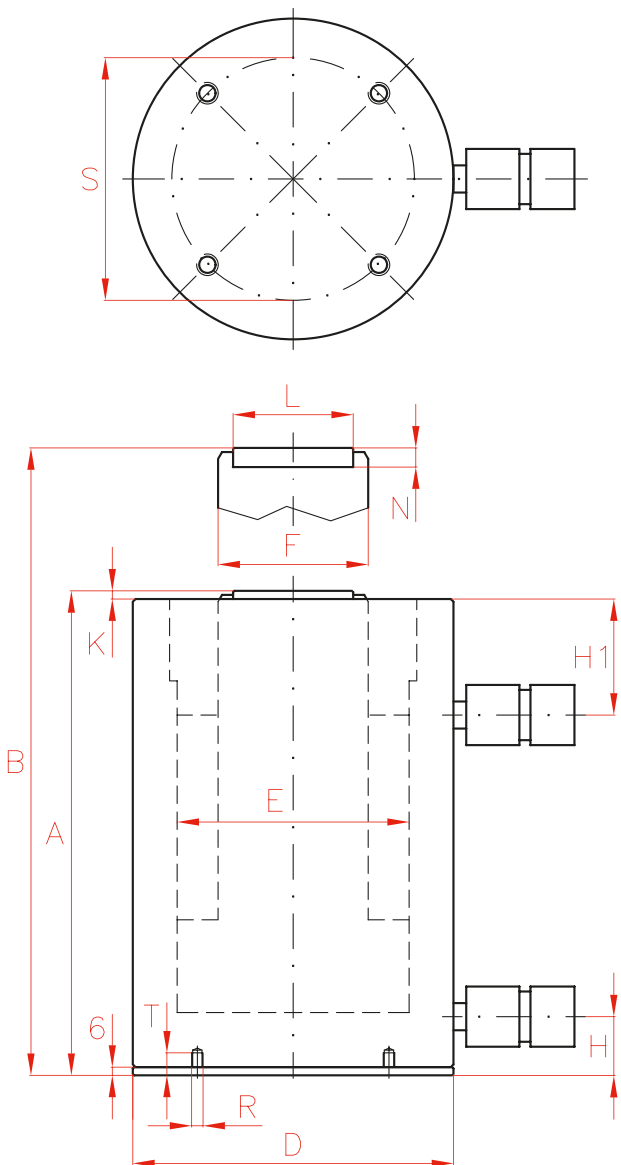

Capacity	Stroke	Model	Capacity (kN)	Oil Cap.	A	
Tn	mm	LARZEP	Push	cm <sup>3</sup>	mm	
50	50	DDA05005	487	354	198	
	100	DDA05010	487	709	248	
	150	DDA05015	487	1.063	298	
	200	DDA05020	487	1.418	348	
	250	DDA05025	487	1.772	398	
	300	DDA05030	487	2.126	448	
75	50	DDA07505	713	520	215	
	100	DDA07510	713	1.039	265	
	150	DDA07515	713	1.558	315	
	200	DDA07520	713	2.077	365	
	250	DDA07525	713	2.597	415	
	300	DDA07530	713	3.116	465	
100	50	DDA10005	911	664	230	
	100	DDA10010	911	1.327	280	
	150	DDA10015	911	1.991	330	
	200	DDA10020	911	2.655	380	
	250	DDA10025	911	3.318	430	
	300	DDA10030	911	3.982	480	
140	50	DDA14005	1.380	1.005	255	
	100	DDA14010	1.380	2.010	305	
	150	DDA14015	1.380	3.016	355	
	200	DDA14020	1.380	4.021	405	
	250	DDA14025	1.380	5.026	455	
	300	DDA14030	1.380	6.031	505	
200	50	DDA20005	1.946	1.418	259	
	100	DDA20010	1.946	2.835	309	
	150	DDA20015	1.946	4.253	359	
	200	DDA20020	1.946	5.670	409	
	250	DDA20025	1.946	7.088	459	
	300	DDA20030	1.946	8.506	509	



OPTIONAL TILTING SADDLES

Model	L	N	Weight
LARZEP	mm	mm	kg
AZ0401	45	36	0,4
AZ0402	61	39	0,8
AZ0404	88	47	2,2
AZ0405	111	52	4,0

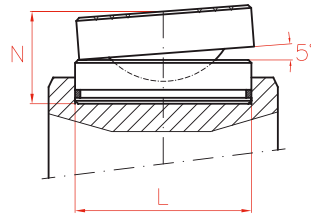

P.118



Type	<b>DDA</b>
Capacity	<b>50 - 200 Tn</b>
Stroke	<b>50 - 300 mm</b>
Max. pressure	<b>700 bar</b>

DDA CYLINDERS

	B	D	E	F	H	H1	K	L	N	S	R	T	Area	Weight	Model	With tilting saddle	
	mm	mm	mm	mm	mm	mm		mm	mm	mm		mm	cm <sup>2</sup>	kg	LARZEP	A	Model
	248	135	95	75	26	60	7	61	12	115	M6	19	71	8,0	DDA05005	225	AZ0402
	348	135	95	75	26	60	7	61	12	115	M6	19	71	9,7	DDA05010	275	AZ0402
	448	135	95	75	26	60	7	61	12	115	M6	19	71	11,3	DDA05015	325	AZ0402
	548	135	95	75	26	60	7	61	12	115	M6	19	71	12,9	DDA05020	375	AZ0402
	648	135	95	75	26	60	7	61	12	115	M6	19	71	14,6	DDA05025	425	AZ0402
	748	135	95	75	26	60	7	61	12	115	M6	19	71	16,2	DDA05030	475	AZ0402
	265	160	115	90	32	70	6	61	12	140	M6	19	104	11,8	DDA07505	242	AZ0402
	365	160	115	90	32	70	6	61	12	140	M6	19	104	14,0	DDA07510	292	AZ0402
	465	160	115	90	32	70	6	61	12	140	M6	19	104	16,3	DDA07515	342	AZ0402
	565	160	115	90	32	70	6	61	12	140	M6	19	104	18,6	DDA07520	392	AZ0402
	665	160	115	90	32	70	6	61	12	140	M6	19	104	20,8	DDA07525	442	AZ0402
	765	160	115	90	32	70	6	61	12	140	M6	19	104	23,1	DDA07530	492	AZ0402
	280	180	130	110	32	70	5	88	14	160	M6	19	133	16,1	DDA10005	263	AZ0404
	380	180	130	110	32	70	5	88	14	160	M6	19	133	19,2	DDA10010	313	AZ0404
	480	180	130	110	32	70	5	88	14	160	M6	19	133	22,2	DDA10015	363	AZ0404
	580	180	130	110	32	70	5	88	14	160	M6	19	133	25,3	DDA10020	413	AZ0404
	680	180	130	110	32	70	5	88	14	160	M6	19	133	28,3	DDA10025	463	AZ0404
	780	180	130	110	32	70	5	88	14	160	M6	19	133	31,3	DDA10030	513	AZ0404
	305	225	160	110	43	85	6	88	14	200	M6	19	201	28,2	DDA14005	288	AZ0404
	405	225	160	110	43	85	6	88	14	200	M6	19	201	32,3	DDA14010	338	AZ0404
	505	225	160	110	43	85	6	88	14	200	M6	19	201	36,4	DDA14015	388	AZ0404
	605	225	160	110	43	85	6	88	14	200	M6	19	201	40,5	DDA14020	438	AZ0404
	705	225	160	110	43	85	6	88	14	200	M6	19	201	44,6	DDA14025	488	AZ0404
	805	225	160	110	43	85	6	88	14	200	M6	19	201	48,7	DDA14030	538	AZ0404
	309	265	190	140	51	85	6	111	15	225	M6	19	284	40,0	DDA20005	296	AZ0405
	409	265	190	140	51	85	6	111	15	225	M6	19	284	45,9	DDA20010	346	AZ0405
	509	265	190	140	51	85	6	111	15	225	M6	19	284	51,8	DDA20015	396	AZ0405
	609	265	190	140	51	85	6	111	15	225	M6	19	284	57,8	DDA20020	446	AZ0405
	709	265	190	140	51	85	6	111	15	225	M6	19	284	63,7	DDA20025	496	AZ0405
	809	265	190	140	51	85	6	111	15	225	M6	19	284	69,6	DDA20030	546	AZ0405

## DOUBLE ACTING HOLLOW PISTON CYLINDERS



- ✓ Capacity from 30 to 150 Tn, stroke up to 250 mm.
- ✓ For push and pull operations: Tensioning cables and bolts, pulling sleeves and bearings.
- ✓ Collar thread, piston end thread and base holes for easy fixing.
- ✓ Safety valve to prevent accidental over-pressure.
- ✓ Hollow plain saddle as standard. Optional solid or threaded saddles available.

Capacity	Stroke	Model	Capacity (kN)		Oil Cap.	A	B	C	D	
			Push	Pull						
Tn	mm	LARZEP			cm <sup>3</sup>	mm	mm	mm	mm	
30	150	DH03015	302	173	660	300	450	33	120	
	250	DH03025	302	173	1.100	400	650	33	120	
60	80	DH06008	578	356	674	249	329	56	165	
	150	DH06015	578	356	1.263	319	469	56	165	
	250	DH06025	578	356	2.105	419	669	56	165	
100	38	DH10004	1.018	647	564	197	235	81	220	
	76	DH10008	1.018	647	1.128	255	331	81	220	
	150	DH10015	1.018	647	2.226	335	485	81	220	
	250	DH10025	1.018	647	3.709	465	715	81	220	
150	200	DH15020	1.407	566	4.096	375	575	81	250	





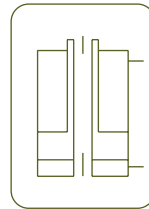
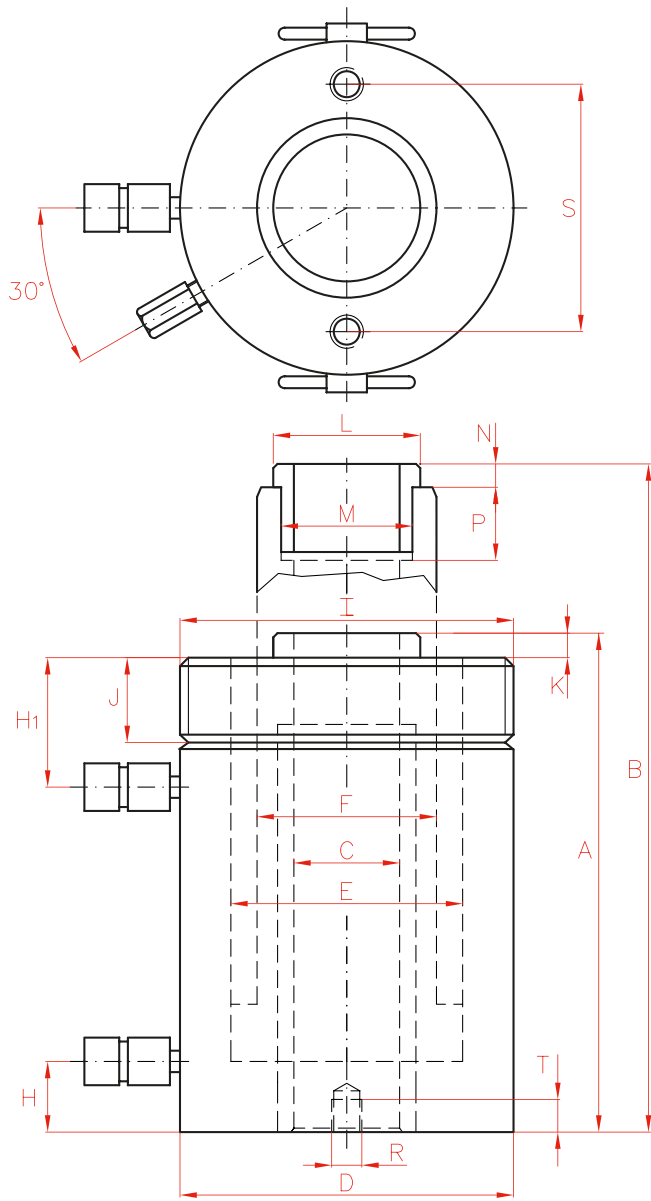

**DOUBLE ACTING HOLLOW CYLINDERS**



Type	<b>DH</b>
Capacity	30 - 150 Tn
Stroke	38 - 250 mm
Max. pressure	700 bar

**DAH**  
Aluminium Double Acting  
Hollow Piston Cylinders



P.70



	E	F	H	H1	I	J	K	L	M	N	P	R	S	T	Area	Weight	Model
	mm	mm	mm	mm	UN	mm	mm	mm	UN	mm	mm	UN	mm	mm	cm <sup>2</sup>	kg	LARZEP
	90	70	27	61	4 1/2"-12	42	4	55	1 13/16"-16	9	22	3/8"-16	92,2	17	44	22	<b>DH03015</b>
	90	70	27	61	4 1/2"-12	42	4	55	1 13/16"-16	9	22	3/8"-16	92,2	17	44	28	<b>DH03025</b>
	125	95	31	66	6 1/4"-12	48	5	80	2 3/4"-16	12	22	1/2"-13	130,3	14	84	35	<b>DH06008</b>
	125	95	31	66	6 1/4"-12	48	5	80	2 3/4"-16	12	22	1/2"-13	130,3	14	84	42	<b>DH06015</b>
	125	95	31	66	6 1/4"-12	48	5	80	2 3/4"-16	12	22	1/2"-13	130,3	14	84	53	<b>DH06025</b>
	170	130	37	60	-	-	5	116	4"-16	13	25	5/8"-11	177,8	19	148	48	<b>DH10004</b>
	170	130	37	80	8 3/8"-12	60	5	116	4"-16	13	25	5/8"-11	177,8	19	148	60	<b>DH10008</b>
	170	130	37	80	8 3/8"-12	60	5	116	4"-16	13	25	5/8"-11	177,8	19	148	76	<b>DH10015</b>
	170	130	37	80	8 3/8"-12	60	5	116	4"-16	13	25	5/8"-11	177,8	19	148	102	<b>DH10025</b>
	190	160	37	60	-	-	10	135	4 1/4"-12	20	40	-	-	-	205	116	<b>DH15020</b>

**ALUMINIUM DOUBLE ACTING, HOLLOW PISTON CYLINDERS**



- ✓ Capacity from 30 to 150 Tn, stroke up to 250 mm.
- ✓ For push and pull operations: Tensioning cable and bolts, pulling sleeves and bearings.
- ✓ Made out of high strength aluminium alloy.
- ✓ All aluminium parts are treated to improve resistance and extend working life.
- ✓ Lightweight. Over 40% weight reduction when compared with steel equivalent.
- ✓ Lighter than single acting SAH equivalent.
- ✓ Fitted with steel base plate for wear resistance.
- ✓ Safety valve to prevent accidental over-pressure.
- ✓ Hollow plain saddle as standard. Optional solid or threaded saddles available.
- ✓ Not suitable for high cycle applications.

Capacity Tn	Stroke mm	Model LARZEP	Capacity (kN)		Oil Cap. cm <sup>3</sup>
			Push	Pull	
30	50	DAH03005	302	173	220
	100	DAH03010	302	173	440
	150	DAH03015	302	173	660
	200	DAH03020	302	173	880
	250	DAH03025	302	173	1.100
60	50	DAH06005	578	356	421
	100	DAH06010	578	356	842
	150	DAH06015	578	356	1.263
	200	DAH06020	578	356	1.684
	250	DAH06025	578	356	2.105
100	50	DAH10005	1.018	647	742
	100	DAH10010	1.018	647	1.484
	150	DAH10015	1.018	647	2.226
	200	DAH10020	1.018	647	2.968
	250	DAH10025	1.018	647	3.710
150	50	DAH15005	1.407	567	1.025
	100	DAH15010	1.407	567	2.050
	150	DAH15015	1.407	567	3.075
	200	DAH15020	1.407	567	4.100
	250	DAH15025	1.407	567	5.125



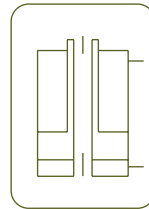
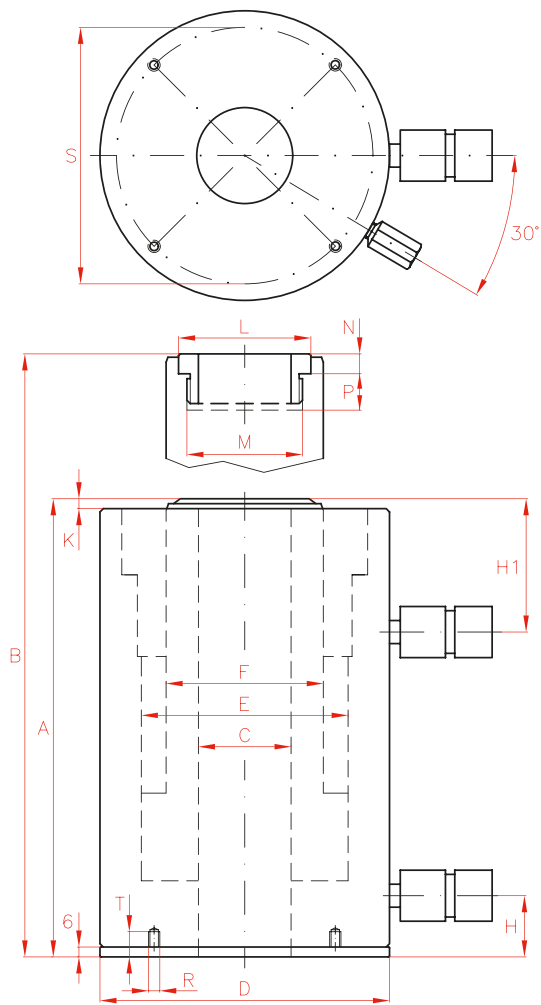

ALUMINIUM D/A HOLLOW CYLINDERS



Type	<b>DAH</b>
Capacity	30 - 150 Tn
Stroke	50 - 250 mm
Max. pressure	700 bar

DAH CYLINDERS

**DH**  
Double Acting Hollow Piston Cylinders



P.68

	A	B	C	D	E	F	H	H1	K	L	M	N	P	R	S	T	Area	Weight	Model
	mm	mm	mm	mm	mm	mm	mm	mm	mm	mm	UN	mm	mm		mm	mm	cm <sup>2</sup>	kg	LARZEP
	217	267	33	130	90	70	32	61	4	55	1 11/13"-16	9	22	M6	110	19	44	7	DAH03005
	267	367	33	130	90	70	32	61	4	55	1 11/13"-16	9	22	M6	110	19	44	9	DAH03010
	317	467	33	130	90	70	32	61	4	55	1 11/13"-16	9	22	M6	110	19	44	12	DAH03015
	367	567	33	130	90	70	32	61	4	55	1 11/13"-16	9	22	M6	110	19	44	13	DAH03020
	417	667	33	130	90	70	32	61	4	55	1 11/13"-16	9	22	M6	110	19	44	15	DAH03025
	225	275	56	175	125	95	37	66	4	80	2 3/4"-16	12	22	M6	155	19	84	13	DAH06005
	275	375	56	175	125	95	37	66	4	80	2 3/4"-16	12	22	M6	155	19	84	16	DAH06010
	325	475	56	175	125	95	37	66	4	80	2 3/4"-16	12	22	M6	155	19	84	19	DAH06015
	375	575	56	175	125	95	37	66	4	80	2 3/4"-16	12	22	M6	155	19	84	22	DAH06020
	425	675	56	175	125	95	37	66	4	80	2 3/4"-16	12	22	M6	155	19	84	25	DAH06025
	256	306	81	235	170	130	40	80	6	116	4"-16	13	25	M6	215	19	148	27	DAH10005
	306	406	81	235	170	130	40	80	6	116	4"-16	13	25	M6	215	19	148	33	DAH10010
	356	506	81	235	170	130	40	80	6	116	4"-16	13	25	M6	215	19	148	38	DAH10015
	406	606	81	235	170	130	40	80	6	116	4"-16	13	25	M6	215	19	148	43	DAH10020
	456	706	81	235	170	130	40	80	6	116	4"-16	13	25	M6	215	19	148	49	DAH10025
	261	311	81	260	190	160	50	80	10	135	4 1/4"-12	20	40	M6	240	19	205	36	DAH15005
	311	411	81	260	190	160	50	80	10	135	4 1/4"-12	20	40	M6	240	19	205	43	DAH15010
	361	511	81	260	190	160	50	80	10	135	4 1/4"-12	20	40	M6	240	19	205	51	DAH15015
	411	611	81	260	190	160	50	80	10	135	4 1/4"-12	20	40	M6	240	19	205	57	DAH15020
	461	711	81	260	190	160	50	80	10	135	4 1/4"-12	20	40	M6	240	19	205	64	DAH15025

## DOUBLE ACTING PRODUCTION CYLINDERS



- ✓ Capacity from 4 to 23 Tn, stroke up to 260 mm.
- ✓ For carrying out push and pull operations.
- ✓ Black nitrided to improve corrosion resistance.
- ✓ Designed for long life in production applications.
- ✓ Big range of mounting accessories: flanges, mounting blocks, nuts and clevis eyes.
- ✓ Metric threads, DM models or UN threads, DI models.



### WARNING

**DM and DI models are not equipped with safety valve to prevent accidental over-pressure.**

## ATTACHMENTS FOR DM AND DI CYLINDERS



Nuts



Clevis Eyes



Mounting Blocks



Flanges



**Nuts**

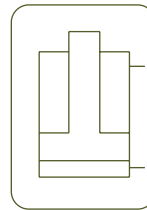
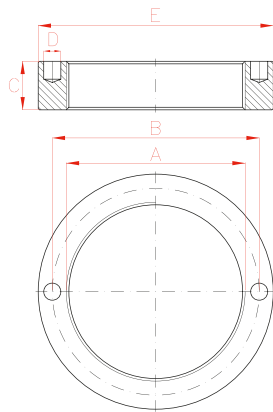

Type	<b>DM - DI</b>
Capacity	4 - 23 Tn
Stroke	28 - 260 mm
Max. pressure	700 bar

DM - DI CYLINDERS

Model	A	B	C	D	E	Weight
LARZEP	mm	mm	mm	mm	mm	kg
<b>DM004RB</b>	M42x1.5	49,5	9,5	6,3	57	0,1
<b>DM008RB</b>	M56x2	65,5	12,7	6,7	75	0,1
<b>DM015RB</b>	M70x2	81,0	19,0	6,7	92	0,4
<b>DM023RB</b>	M85x2	96,5	25,4	6,7	108	0,7

Model	A	B	C	D	E	Weight
LARZEP	UN	mm	mm	mm	mm	kg
<b>DI004RB</b>	1 3/8"-12	49,5	9,5	6,3	57	0,1
<b>DI008RB</b>	2"-12	65,5	12,7	6,7	75	0,1
<b>DI015RB</b>	2 5/8"-16	81,0	19,0	6,7	92	0,4
<b>DI023RB</b>	3 1/4"-16	96,5	25,4	6,7	108	0,7

**Clevis Eyes**

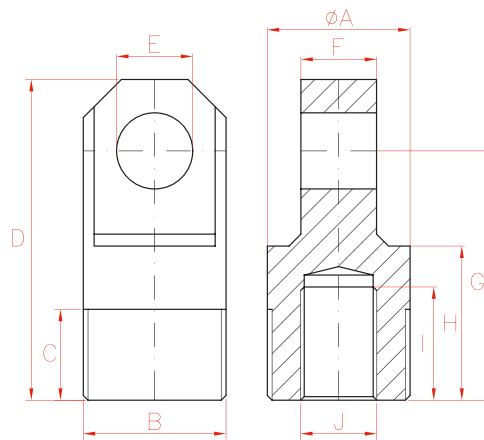

Model	A	B	C	D	E	F	G	H	I	J	Weight
LARZEP	mm	mm	mm	mm	mm	mm	mm	mm	mm	mm	kg
<b>DM004RP</b>	30	M30x1.5	19,1	67,4	16	15,9	52,4	32,4	23,8	M16x1,5	0,2
<b>DM008RP</b>	42	M42x1.5	25,4	78,1	20	25,4	57,1	37,1	23,8	M22x1,5	0,6
<b>DM015RP</b>	56	M56x2	25,4	105,8	25	31,9	77,8	52,8	30,2	M30x1,5	1,3
<b>DM023RP</b>	70	M70x2	25,4	112,8	32	38,2	77,8	50,3	27,0	M42x1,5	2,1

Model	A	B	C	D	E	F	G	H	I	J	Weight
LARZEP	mm	UN	mm	mm	mm	mm	mm	mm	mm	UN	kg
<b>DI004RP</b>	30	1 1/8"-20	19,1	67,4	16	15,9	52,4	32,4	23,8	1 1/2"-20	0,2
<b>DI008RP</b>	42	1 11/16"-18	25,4	78,1	20	25,4	57,1	37,1	23,8	3/4"-16	0,6
<b>DI015RP</b>	56	2 3/16"-16	25,4	105,8	25	31,9	77,8	52,8	30,2	1 1/8"-12	1,3
<b>DI023RP</b>	70	2 3/4"-16	25,4	112,8	32	38,2	77,8	50,3	27,0	1 1/2"-12	2,1



### Mounting Blocks

Model	A	B	C	D	E	F	G	H	Weight
LARZEP	mm	mm	mm	mm	mm	mm	mm	mm	kg
DM004RC	18	10,5	57,0	31,8	20	80	58,0	42,1	0,4
DM008RC	21	13,5	82,5	44,5	25	105	78,0	56,1	1,2
DM015RC	28	20,0	100,0	52,4	35	127	95,2	70,1	2,9
DM023RC	36	26,5	125,0	63,5	45	159	117,5	85,1	4,5

Model	A	B	C	D	E	F	G	H	Weight
LARZEP	mm	mm	mm	mm	mm	mm	mm	mm	kg
DI004RC	16	10,5	57,0	31,8	19,3	72,6	50,8	35,1	0,4
DI008RC	20	13,5	82,5	44,5	25,4	101,6	73,2	50,9	1,2
DI015RC	28	20,0	101,6	52,3	35,0	127,0	95,5	66,9	2,9
DI023RC	36	26,5	125,0	63,5	45,0	159,0	117,4	82,7	4,5

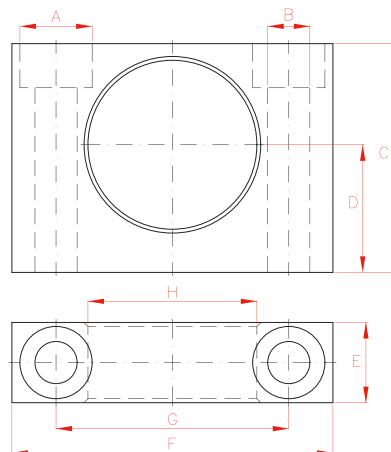

To use these attachments the nut DM\_RB or DI\_RB is required..

### CYLINDERS WITH METRIC THREAD - DM

Capacity	Stroke	Model	Capacity (kN)		Area (cm <sup>2</sup> )		Oil Cap.	A
			Push	Pull	Push	Pull		
4	28	DM00403	34	12	5	2	14	186
	79	DM00408	34	12	5	2	39	237
	155	DM00416	34	12	5	2	76	313
8	28	DM00803	86	44	13	6	35	223
	79	DM00808	86	44	13	6	99	274
	155	DM00816	86	44	13	6	195	350
15	257	DM00826	86	44	13	6	323	452
	159	DM01516	139	73	20	11	323	389
23	260	DM01526	139	73	20	11	527	490
	159	DM02316	228	93	33	14	527	425
23	260	DM02326	228	93	33	14	863	526

### CYLINDERS WITH UN THREAD - DI

Capacity	Stroke	Model	Capacity (kN)		Area (cm <sup>2</sup> )		Oil Cap.	A
			Push	Pull	Push	Pull		
4	28	DI00403	34	12	5	2	14	186
	79	DI00408	34	12	5	2	39	237
	155	DI00416	34	12	5	2	76	313
8	28	DI00803	86	44	13	6	35	223
	79	DI00808	86	44	13	6	99	274
	155	DI00816	86	44	13	6	195	350
15	257	DI00826	86	44	13	6	323	452
	159	DI01516	139	73	20	11	323	389
23	260	DI01526	139	73	20	11	527	490
	159	DI02316	228	93	33	14	527	425
23	260	DI02326	228	93	33	14	863	526

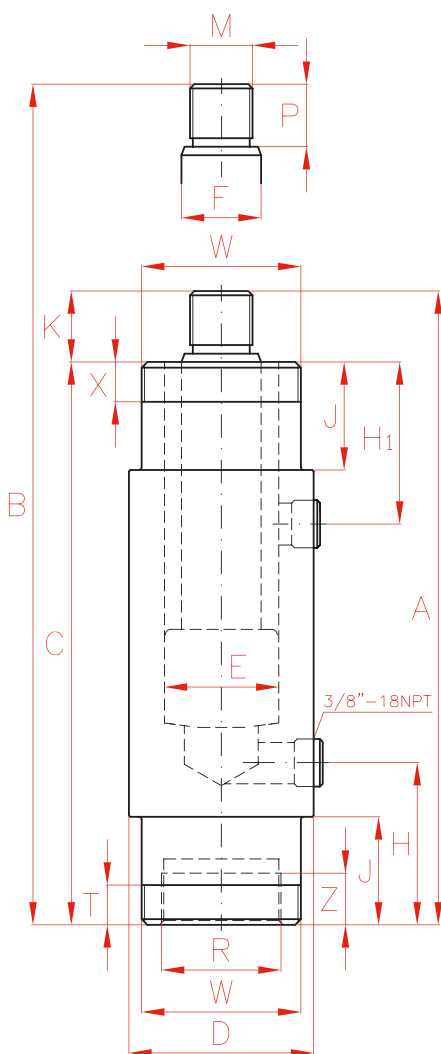

NOTE: 4Tn cylinders have 1/4" BSP thread for the couplers.



Flanges

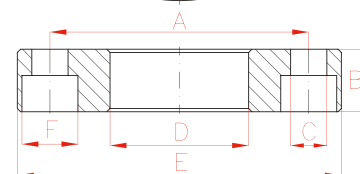
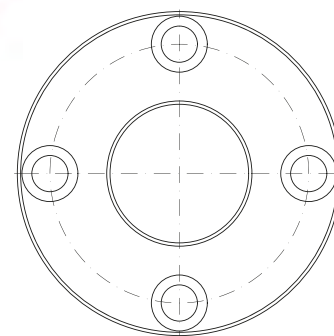

Model	A	B	C	D	E	F	Weight
LARZEP	mm	mm	mm	mm	mm	mm	kg
DM004RS	78,6	19,0	11,0	42,1	98,4	17	1,0
DM008RS	98,4	25,4	11,0	56,1	120,5	17	2,1
DM015RS	115,9	35,0	13,4	70,1	143,0	18	3,8
DM023RS	135,7	44,5	17,0	85,1	165,0	22	6,0

Model	A	B	C	D	E	F	Weight
LARZEP	mm	mm	mm	mm	mm	mm	kg
DI004RS	78,6	19,0	10,4	35,1	98,4	15	1,0
DI008RS	98,5	25,4	10,5	50,9	120,7	15	2,1
DI015RS	115,9	35,0	13,5	66,8	143,0	20	3,8
DI023RS	135,7	44,5	17,0	82,7	165,0	23	6,0



To use these attachments the nut DM\_RB or DI\_RB is required..

	B	C	D	E	F	H	H1	K	J	M	P	R	W	X	Z	Weight	Model
	mm	mm	mm	mm	mm	mm	mm	mm	mm	mm	mm	mm	mm	mm	mm	kg	LARZEP
	214	162	51	25	20	47	61	24	29	M16x1.5	19	M30x1.5	M42x1.5	11	9	2,0	DM00403
	316	213	51	25	20	47	61	24	29	M16x1.5	19	M30x1.5	M42x1.5	11	9	2,9	DM00408
	468	289	51	25	20	47	61	24	29	M16x1.5	19	M30x1.5	M42x1.5	11	9	3,9	DM00416
	251	198	65	40	28	75	57	25	38	M22x1.5	22	M42x1.5	M56x2	14	14	4,2	DM00803
	353	249	65	40	28	75	57	25	38	M22x1.5	22	M42x1.5	M56x2	14	14	5,3	DM00808
	505	325	65	40	28	75	57	25	38	M22x1.5	22	M42x1.5	M56x2	14	14	6,8	DM00816
	709	427	65	40	28	75	57	25	38	M22x1.5	22	M42x1.5	M56x2	14	14	9,0	DM00826
	548	359	80	51	35	73	95	30	54	M30x1.5	28	M56x2	M70x2	22	24	9,0	DM01516
	750	460	80	51	35	73	95	30	54	M30x1.5	28	M56x2	M70x2	22	24	11,7	DM01526
	584	398	92	65	50	89	110	27	70	M42x1.5	25	M70x2	M85x2	29	26	17,0	DM02316
	786	499	92	65	50	89	110	27	70	M42x1.5	25	M70x2	M85x2	29	26	21,0	DM02326



**WARNING** DM and DI models are not equipped with safety valve to prevent accidental over-pressure!

	B	C	D	E	F	H	H1	K	J	M	P	R	W	X	Z	Weight	Model
	mm	mm	mm	mm	mm	mm	mm	mm	mm	UN	mm	UN	UN	mm	mm	kg	LARZEP
	214	162	51	25	20	47	61	24	29	1/2"-20	19	1 1/8"-20	1 3/8"-12	11	9	2,0	DI00403
	316	213	51	25	20	47	61	24	29	1/2"-20	19	1 1/8"-20	1 3/8"-12	11	9	2,9	DI00408
	468	289	51	25	20	47	61	24	29	1/2"-20	19	1 1/8"-20	1 3/8"-12	11	9	3,9	DI00416
	251	198	65	40	28	75	57	25	38	3/4"-16	22	1 1/16"-18	2"-12	14	14	3,7	DI00803
	353	249	65	40	28	75	57	25	38	3/4"-16	22	1 1/16"-18	2"-12	14	14	4,7	DI00808
	505	325	65	40	28	75	57	25	38	3/4"-16	22	1 1/16"-18	2"-12	14	14	6,4	DI00816
	709	427	65	40	28	75	57	25	38	3/4"-16	22	1 1/16"-18	2"-12	14	14	9,0	DI00826
	548	359	80	51	35	73	95	30	54	1 1/8"-12	28	2 3/16"-16	2 5/8"-16	22	24	9,0	DI01516
	750	460	80	51	35	73	95	30	54	1 1/8"-12	28	2 3/16"-16	2 5/8"-16	22	24	11,7	DI01526
	584	398	92	65	50	89	110	27	70	1 1/2"-12	25	2 3/4"-16	3 1/4"-16	29	26	17,0	DI02316
	786	499	92	65	50	89	110	27	70	1 1/2"-12	25	2 3/4"-16	3 1/4"-16	29	26	21,0	DI02326

**CYLINDER - PUMP SETS**



- ✓ All sets include 2 m hose (AP2020), male coupler (AZ3120), pressure gauge (AV10006) and gauge adaptor (AZ1502).
- ✓ Available with hand pump or air hydraulic pump.
- ✓ Available Cylinder-Pump set without pressure gauge or gauge adaptor. Add 'G' to the reference.

**SINGLE ACTING, HOLLOW PISTON CYLINDER**

Capacity		Stroke	Closed Height	Cylinder	Hand Pump 1 <sup>st</sup> Stage	Hand Pump 1 <sup>st</sup> Stage	Hand Pump 1 <sup>st</sup> Stage	Hand Pump 2 <sup>nd</sup> Stage	Hand Pump 2 <sup>nd</sup> Stage	Air Hydraulic Pump
Tn	kN	mm	mm	LARZEP	W00307	W10707	W20707	W21207	W22307	Z12107
12	121	40	124	SH01204	JH01204					JHZ01204
22	217	50	165	SH02205		JH02205				JHZ02205
30	302	64	197	SH03006			JH03006			JHZ03006
60	578	76	223	SH06008				JH06008		JHZ06008
100	1.018	80	282	SH10008					JH10008	JHZ10008



**W**  
Single Acting Hand Pumps.



P.80

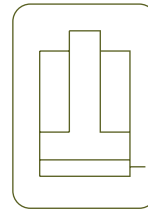

Type	<b>J</b>
Capacity	5 - 100 Tn
Stroke	40 - 362 mm
Max. pressure	700 bar

**Z12107**  
Air Hydraulic Pump



P.86

**SINGLE ACTING, SPRING RETURN CYLINDER**

Capacity		Stroke	Closed Height	Cylinder	Hand Pump 1 <sup>st</sup> Stage	Hand Pump 1 <sup>st</sup> Stage	Hand Pump 1 <sup>st</sup> Stage	Hand Pump 2 <sup>nd</sup> Stage	Hand Pump 2 <sup>nd</sup> Stage	Air Hydraulic Pump
Tn	kN	mm	mm	LARZEP	W00307	W10707	W20707	W21207	W22307	Z12107
5	49	76	168	SM00508	JM00508					JMZ00508
		127	219	SM00513	JM00513					JMZ00513
10	109	54	121	SM01005	JM01005					JMZ01005
		155	247	SM01015		JM01015				JMZ01015
		257	352	SM01025			JM01025			JMZ01025
15	163	105	205	SM01510		JM01510				JMZ01510
		155	275	SM01515			JM01515			JMZ01515
23	228	51	166	SM02305		JM02305				JMZ02305
		102	217	SM02310		JM02310				JMZ02310
		159	277	SM02315			JM02315			JMZ02315
		261	379	SM02326				JM02326		JMZ02336
		362	480	SM02336					JM02336	JMZ02336
30	303	210	340	SM03021				JM03021	JMZ03021	
50	487	160	285	SM05016				JM05016	JMZ05016	
100	911	150	300	SM10015				JM10015	JMZ10015	

**LOW HEIGHT, SINGLE ACTING, SPRING RETURN CYLINDER**

Capacity		Stroke	Closed Height	Cylinder	Hand Pump 1 <sup>st</sup> Stage	Hand Pump 1 <sup>st</sup> Stage	Hand Pump 1 <sup>st</sup> Stage	Hand Pump 2 <sup>nd</sup> Stage	Hand Pump 2 <sup>nd</sup> Stage	Air Hydraulic Pump
Tn	kN	mm	mm	LARZEP	W00307	W10707	W20707	W21207	W22307	Z12107
10	109	40	89	SMP01004	JP01004					JPZ01004
20	214	40	101	SMP02004		JP02004				JPZ02004
30	303	60	125	SMP03006			JP03006			JPZ03006
50	486	60	125	SMP05006			JP05006			JPZ05006
100	911	60	141	SMP10006				JP10006		JPZ10006

## HYDRAULIC PUMPS



















**LARZEP** Pumps are available in a wide range of models: Hand pumps, Air hydraulic pumps, Modular pumps, Manual, Electric, Air and Petrol hydraulic powerpacks, Split-Flow powerpacks, Hydrotest pumps, Battery powered pumps, Torque wrench pumps.

- ✓ 700 bar pumps as standard.
- ✓ 700 and 1.000 bar air hydraulic pumps.
- ✓ From 20 to 2.900 bar hydrotest pumps.
- ✓ Air, electric and hand operated hydrotest pumps.
- ✓ Wide range of reservoirs, from 240cc in hand pumps to 150 litres in standard powerpacks.
- ✓ Possibility to manufacture powerpacks up to 1.000 litres.
- ✓ Powerpacks according to ATEX standards upon request.





# PUMPS

Models	Pump type	Max. Oil Capacity litre	Max. Flow Rate l/min		Page
<b>W</b>	Hydraulic Single Acting Hand Pumps	7,5	4,6 cm <sup>3</sup> /stroke		80
<b>X</b>	Hydraulic Double Acting Hand Pumps	7,5	4,6 cm <sup>3</sup> /stroke		80
<b>WA</b>	Hydraulic Aluminium Hand Pumps	1,1	3,1 cm <sup>3</sup> /stroke		82
<b>WA</b>	Hydraulic Aluminium Hand Pump 2.800 bar	1,0	0,65 cm <sup>3</sup> /stroke		84
<b>Z - ZR</b>	Air Hydraulic Pumps 700 bar	20	0,14		86
<b>Z</b>	Air Hydraulic Pumps 1.000 bar	4	0,08		86
<b>HBM</b>	Hydraulic Powerpacks Manual valve	100	3,28		88
<b>HBE</b>	Hydraulic Powerpacks Solenoid valve	100	3,28		90
<b>HBM - HBE</b>	HBM and HBE Powerpacks Selection Tables			Build your powerpack using the charts	92
<b>HAZ</b>	Air Driven Hydraulic Pumps	100	2,2		94
<b>HAG</b>	Petrol Hydraulic Pumps	50	0,36		95
<b>B - C - D - H P - R</b>	Accessories for Powerpacks				96
<b>HFM - HFE</b>	Split-Flow Powerpacks	150	2,0		98
<b>WI</b>	Modular Hand Pumps		36 cm <sup>3</sup> /stroke		100
<b>HAB</b>	Battery Powered Portable Hydraulic Pump	2,3	0,16		101
<b>HAP</b>	Air Driven Hydrotest Pumps	7	3,5		102
<b>WAP - WIP</b>	Hydrotest Hand Pumps	100	20		104
<b>HEP</b>	Electric Hydrotest Pumps	100	15 cm <sup>3</sup> /stroke		106
<b>HAT</b>	Torque Wrench Pumps	14	0,36		108

**HYDRAULIC HAND PUMPS**



**W Single acting**



**X Double acting**

- ✓ W series pumps are for use with Single Acting cylinders.
- ✓ X series pumps are fitted with 4-way 3 position valve for use with Double Acting cylinders.
- ✓ The pump range includes single and two speed models. Two speed models provide rapid cylinder advance until contact is made with the load.
- ✓ Hydraulic port on all models is 3/8"-NPT female.
- ✓ W and X series pumps are fitted with internal safety valves to prevent overpressure.
- ✓ WP21007 and XP21007 models are foot pedal operated.
- ✓ All pumps except W00307 are fitted with handle clips for ease of carrying.

**SINGLE ACTING**

Model	Speeds	Usable oil	Handle effort
LARZEP	No.	cm <sup>3</sup>	kg
W00307	1	240	51
W10707	1	660	49
W20707	2	660	49
WP21007	2	1.000	43
W11207	1	1.200	49
W21207	2	1.200	49
W22307	2	2.400	49
W24307	2	4.200	49
W07807	2	7.500	41

**DOUBLE ACTING**

Model	Speeds	Usable oil	Handle effort
LARZEP	No.	cm <sup>3</sup>	kg
XP21007	2	1.000	43
X22307	2	2.400	49
X24307	2	4.200	49
X07807	2	7.500	41



**SINGLE ACTING W**

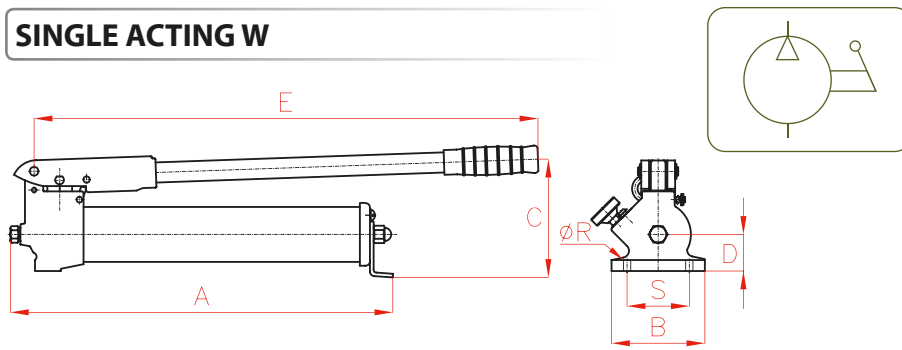

Type **W - X**

Capacity **0,24 - 7,5 litres**

Max. pressure **700 bar**

**DOUBLE ACTING X**

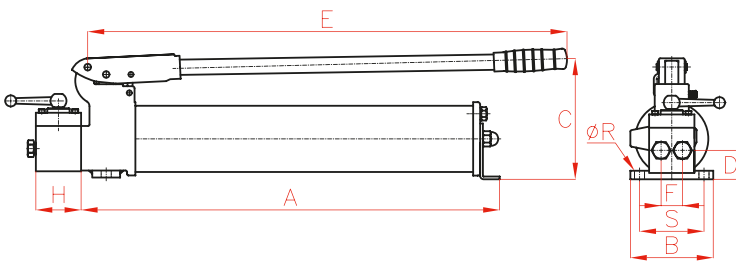

WP21007 pump, foot pedal operated.

**W07807 / X07807**

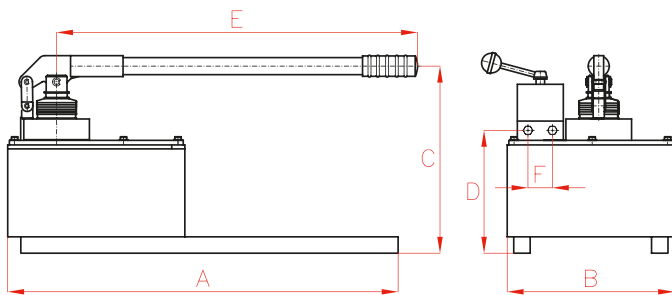

W07807, X07807 pumps.

	Oil displacement per stroke (cm <sup>3</sup> )		Pressure rating (bar)		A	B	C	D	E	R	S	Weight	Model
	1 <sup>st</sup> Stage	2 <sup>nd</sup> Stage	1 <sup>st</sup> Stage	2 <sup>nd</sup> Stage	mm	mm	mm	mm	mm	mm	mm		
	-	2,2	-	700	350	100	110	25	380	-	-	2,7	<b>W00307</b>
	-	2,6	-	700	500	100	150	40	560	-	-	5,5	<b>W10707</b>
	8,1	2,0	20	700	500	100	150	40	560	-	-	5,5	<b>W20707</b>
	12,0	2,0	50	700	582	189	445*	52	540	9	185	9,0	<b>WP21007</b>
	-	2,6	-	700	545	100	175	40	560	-	-	6,5	<b>W11207</b>
	8,1	2,0	20	700	545	100	175	40	560	-	-	6,5	<b>W21207</b>
	13,2	2,2	20	700	560	108	210	55	560	8,5	86	12,0	<b>W22307</b>
	16,5	2,8	20	700	570	108	210	75	560	8,5	86	20,0	<b>W24307</b>
	120,0	4,6	10	700	610	242	250	232	643	-	-	30,0	<b>W07807</b>

\* with the pedal completely open

	Oil displacement per stroke (cm <sup>3</sup> )		Pressure rating (bar)		A	B	C	D	E	F	H	R	S	Weight	Model
	1 <sup>st</sup> Stage	2 <sup>nd</sup> Stage	1 <sup>st</sup> Stage	2 <sup>nd</sup> Stage	mm	mm	mm	mm	mm	mm	mm	mm	mm		
	12,0	2,0	50	700	550	197	445*	52	540	-	-	9	185	9,0	<b>XP21007</b>
	13,2	2,2	20	700	560	108	210	55	560	40	50	8,5	86	14	<b>X22307</b>
	16,5	2,8	20	700	570	108	210	75	560	40	50	8,5	86	23	<b>X24307</b>
	120,0	4,6	10	700	610	242	250	232	643	30	-	-	-	32	<b>X07807</b>

## HYDRAULIC ALUMINIUM HAND PUMPS



- ✓ WA series pumps are for use with Single Acting cylinders.
- ✓ Lightweight aluminium pumps, ideal for easy portability and handling.
- ✓ Two speed models to provide rapid cylinder advance until contact is made with the load.
- ✓ Hydraulic outlet port: 3/8"-NPT female.
- ✓ Fitted with safety valves to prevent overpressure.
- ✓ Fitted with handle clip for ease of carrying.

Model	Usable oil cm <sup>3</sup>	Handle effort kg	Oil displacement per stroke (cm <sup>3</sup> )		Pressure rating (bar)		Weight kg
			1 <sup>st</sup> Stage	2 <sup>nd</sup> Stage	1 <sup>st</sup> Stage	2 <sup>nd</sup> Stage	
<b>WA20507</b>	500	29	13,4	2,6	20	700	3,7
<b>WA21107</b>	1.100	43	15,0	3,1	20	700	5,0



**AZ3**  
Coupler 3/8"-18 NPT



P.114

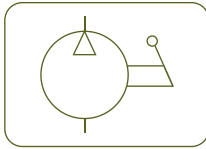

**AV - AVD - AT - AY**  
Pressure Gauges



P.123

**HYDRAULIC ALUM. HAND PUMPS**



Type **WA**

Capacity **0,5 - 1,1 litres**

Max. pressure **700 bar**

**WA21028**  
Aluminium Hand Pumps, 2.800 bar



P.84

**W**  
Single Acting Hand Pumps



P.80

**X**  
Double Acting Hand Pumps



P.80

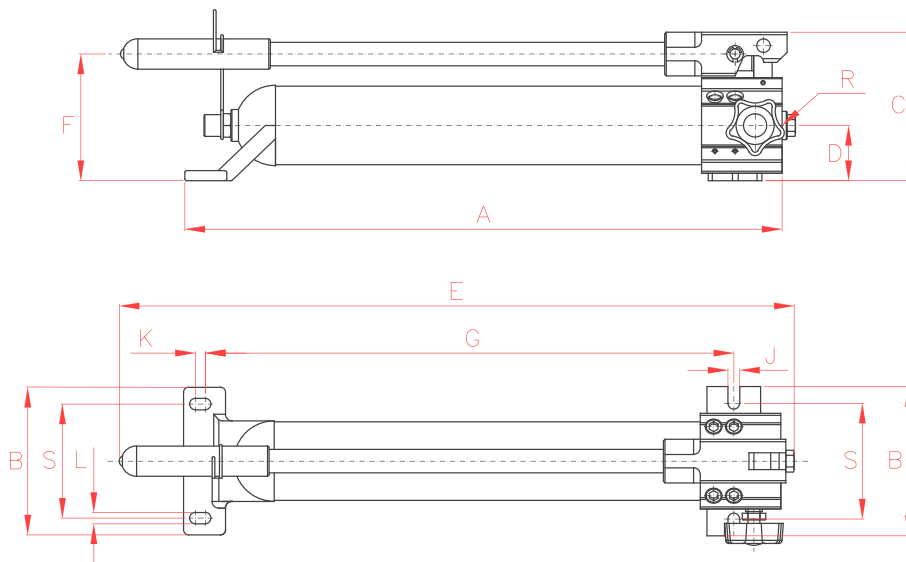

A	B	C	D	E	F	G	H	J	K	L	R	Model
mm	mm	mm	mm	mm	mm	mm	mm	mm	mm	mm	NPT	LARZEP
361	140	141	51	435	124	295,0	108	11,2	10	11,2	3/8"-NPT	<b>WA20507</b>
556	140	141	51	625	124	489,5	108	11,2	10	11,2	3/8"-NPT	<b>WA21107</b>

WA PUMPS



**ULTRA HIGH PRESSURE ALUMINIUM HAND PUMP (2.800 BAR)**



- ✓ WA series pumps are for use with Single Acting tools.
- ✓ Lightweight aluminium pump, ideal for easy portability and handling.
- ✓ Two speed models.
- ✓ Hydraulic outlet port: 3/4"-16 UNF female.
- ✓ Fitted with handle clip for ease of carrying.
- ✓ 3.000 bar accessories available: hoses, couplers, adaptors and gauge.

**3.000 BAR PRESSURE GAUGE**

Model	Pressure	Scale	Ext. Ø	Width	Thread	Model
LARZEP	bar	bar	mm	mm	mm	LARZEP
AV43010	3.000	50	100	60	Female M16x1.5	AZ1530

**3.000 BAR GAUGE ADAPTOR**

Model	A	B
LARZEP	60° Cone	60° Cone
AZ1530	3/4"-16 UNF	M16x1.5

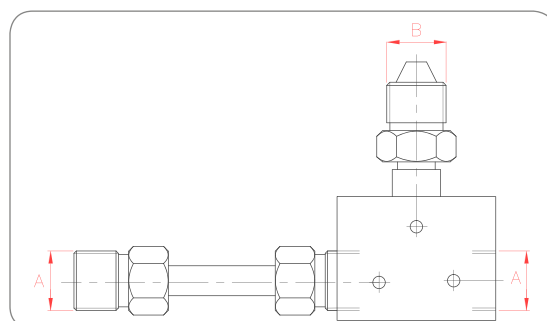

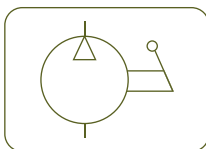

Type	<b>WA</b>
Capacity	<b>1,0 litre</b>
Max. pressure	<b>2.800 bar</b>

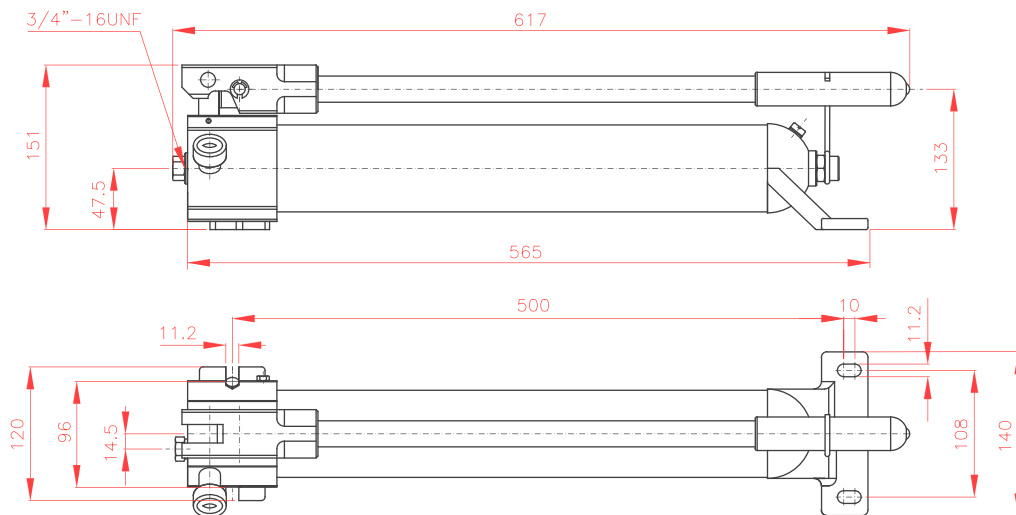

Model	Usable oil cm <sup>3</sup>	Handle effort kg	Oil displacement per stroke (cm <sup>3</sup> )		Pressure rating (bar)		Weight kg
			1 <sup>st</sup> Stage	2 <sup>nd</sup> Stage	1 <sup>st</sup> Stage	2 <sup>nd</sup> Stage	
<b>WA21028</b>	1.000	43	12,9	0,65	14	2.800	4,5

**HOSES MAXIMUM WORKING PRESSURE 3.000 BAR**

Int. Ø mm	End mm	Pressure bar	Length (m)							
			0,8	1,5	2	3	4	6	8	10
3,9	M16x1.5	3.000	<b>AP6008</b>	<b>AP6015</b>	<b>AP6020</b>	<b>AP6030</b>	<b>AP6040</b>	<b>AP6060</b>	<b>AP6080</b>	<b>AP6100</b>

**3.000 BAR ADAPTOR**

Model	A	B	C	D
LARZEP	60° Cone	60° Cone	mm	mm
<b>AZ1107</b>	3/4"-16 UNF	M16x1.5	50	22

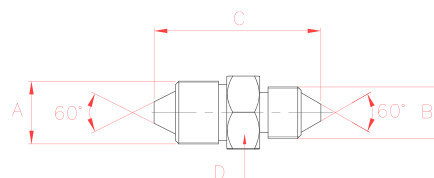

**3.000 BAR BALL COUPLERS**

Flow l/min	Coupling	Model	Thread	Pressure bar
4,6	Male	<b>AZ3330</b>	Female M16x1.5	3.000
	Female	<b>AZ3350</b>	Female M16x1.5	3.000

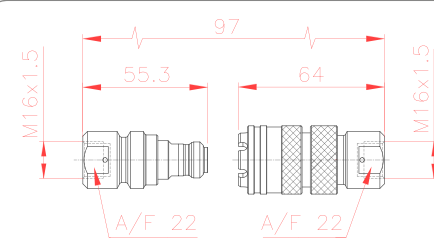

WA PUMPS

## AIR HYDRAULIC PUMPS



- ✓ On Z models for Single Acting cylinders, the pedal acts as the control valve, by controlling advance, hold and retract functions. In 'hold' mode, the pump maintains the output pressure.
- ✓ On ZR models, operation is controlled by a remote pendant.
- ✓ Double Acting models are fitted with a manual 4-way 3 position control valve.
- ✓ The hydraulic port on all models is 3/8"-NPT female.
- ✓ Working pressures 700 bar and 1.000 bar.
- ✓ Easily accessible adjustable relief valve.
- ✓ 4, 7, 10 and 20 litre pumps are fitted with steel tanks.
- ✓ Optional steel base plate available for Z12107 part number.
- ✓ Aluminium free models available as special.
- ✓ Air Inlet Port: 1/4" BSP female.
- ✓ Air Pressure: 2,8 - 10 bar.
- ✓ Air Consumption: 400 N l/min.
- ✓ 700 bar Flow Rate: 0,14 l/min.
- ✓ 1.000 bar Flow Rate: 0,08 l/min.
- ✓ Sound level: 75 dBA

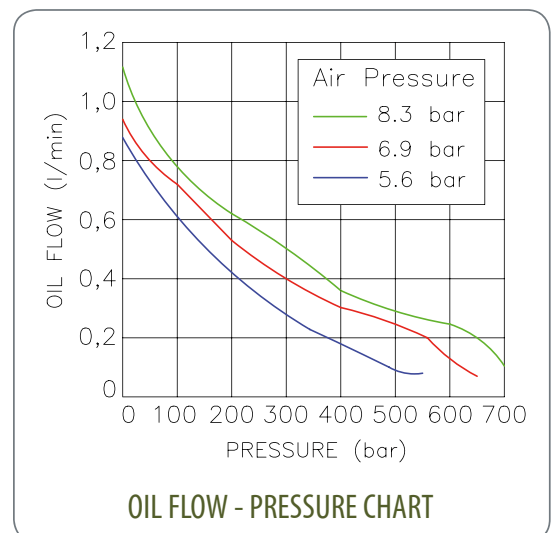

Models:  
Z12107  
Z14007  
Z17007  
Z19107  
Z19207  
Z12110  
Z14010

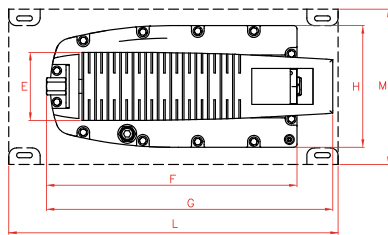
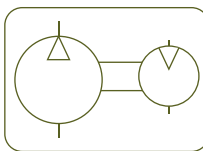
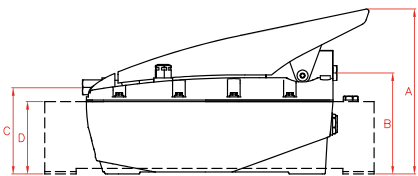

Models:  
Z22107  
Z24007  
Z27007  
Z29107  
Z29207

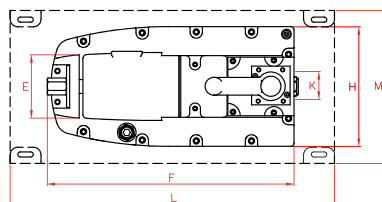
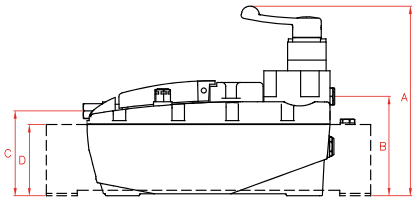

Models:  
ZR12107  
ZR14007  
ZR17007  
ZR19107  
ZR19207

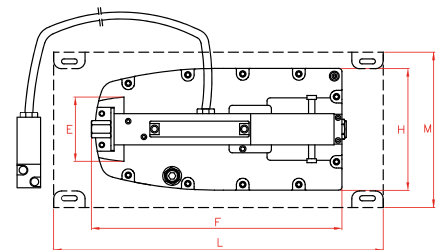
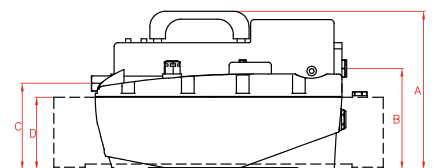

Type **Z - ZR**

Capacity **2,1 - 20 litres**

Max. pressure **700 - 1.000 bar**

Z - ZR PUMPS

**700 BAR WORKING PRESSURE**

Type	Oil capacity	Model	A	B	C	D	E	F	G	H	K	L	M	Weight
	litres	LARZEP	mm	mm	mm	mm	mm	mm	mm	mm	mm	mm	mm	kg
Single Acting	2,1	Z12107	209	127	109	-	82	320	364	155	-	-	-	7,6
Single Acting	4,0	Z14007	256	173	154	137	82	320	364	155	-	350	178	14,4
Single Acting	6,9	Z17007	256	173	154	137	82	320	364	155	-	415	206	19,2
Single Acting	10,0	Z19107	278	198	180	162	82	320	364	155	-	430	220	21,8
Single Acting	20,0	Z19207	278	198	180	162	82	320	364	155	-	500	356	29,1
Double Acting	2,1	Z22107	245	131	110	-	82	320	-	155	36	-	-	8,4
Double Acting	4,0	Z24007	290	176	154	137	82	320	-	155	36	350	178	15,2
Double Acting	6,9	Z27007	290	176	154	137	82	320	-	155	36	415	206	20,4
Double Acting	10,0	Z29107	315	201	180	162	82	320	-	155	36	430	220	23
Double Acting	20,0	Z29207	315	201	180	162	82	320	-	155	36	500	356	30,3
Single Acting	2,1	ZR12107	217	129	111	-	82	316	-	155	-	-	-	8,6
Single Acting	4,0	ZR14007	261	173	155	137	82	316	-	155	-	350	178	15,2
Single Acting	6,9	ZR17007	261	173	155	137	82	316	-	155	-	415	206	20,4
Single Acting	10,0	ZR19107	286	198	180	162	82	316	-	155	-	430	220	23
Single Acting	20,0	ZR19207	286	198	180	162	82	316	-	155	-	500	356	30,3
Double Acting	2,1	ZR22107	213	127	109	-	82	325	-	155	36	-	-	8,6
Double Acting	4,0	ZR24007	258	172	154	137	82	325	-	155	36	350	178	15,2
Double Acting	6,9	ZR27007	258	172	154	137	82	325	-	155	36	415	206	20,4

**1.000 BAR WORKING PRESSURE**

Type	Oil capacity	Model	A	B	C	D	E	F	G	H	K	L	M	Weight
	litres	LARZEP	mm	mm	mm	mm	mm	mm	mm	mm	mm	mm	mm	kg
Single Acting	2,1	Z12110	209	127	109	-	87	320	364	155	-	-	-	7,6
Single Acting	4,0	Z14010	221	139	120	104	87	320	364	155	-	420	240	14,4

**HYDRAULIC ELECTRIC PUMPS (MANUAL VALVE)**



- ✓ Manual directional control valves.
- ✓ Also available HBE model, remote pendant controlled solenoid valves.
- ✓ The manual control valve is easily converted from double acting to single acting operation.
- ✓ Internal safety valve set at 700 bar to prevent overpressure.
- ✓ External adjustable pressure relief valve.
- ✓ For use with single acting or double acting cylinders for heavy lifting or production applications.
- ✓ Options: roll bars, heat exchanger, pressure gauge (glycerine or digital), wheel kit, pedal and push button remote motor control.

NOTE: Pressure gauge is not included.

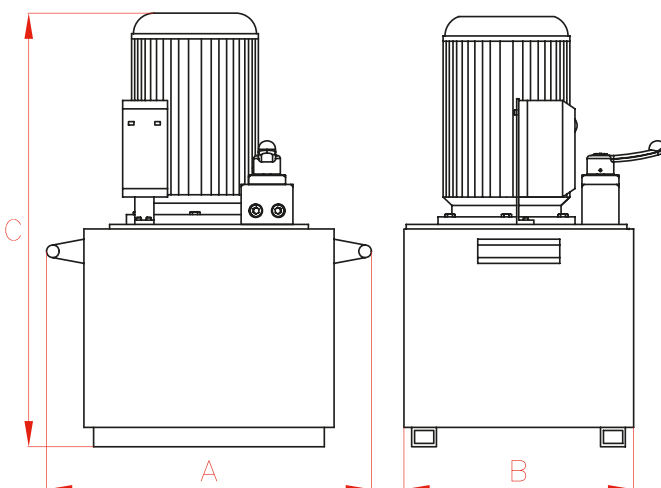

Capacity	A	B	C
l	mm	mm	mm
5	330	230	500
8,5	350	250	525
12,5	370	290	550
25	470	360	670
50	540	415	750
100	830	500	840





**PUMP**  
Accessories



P.96

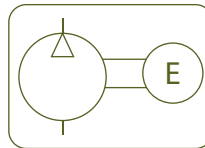

**HYDRAULIC POWERPACKS**



Type **HBM**

Capacity **5 - 100 litres**

Max. pressure **700 bar**

50-60 Hz 3 phase								
Tank	Flow at 700 bar	Flow at 50 bar	230 V		380V/415V		Power	Weight
l	l/min	l/min	S/A	D/A	S/A	D/A	kW	kg
5	0,36	4,00	HBM7222	HBM7242	HBM7224	HBM7244	0,75	21
8,5	0,54	5,90	HBM3322	HBM3342	HBM3324	HBM3344	1,10	30
12,5	0,54	5,90	HBM3422	HBM3442	HBM3424	HBM3444	1,10	38
12,5	0,82	8,64	HBM4422	HBM4442	HBM4424	HBM4444	1,10	40
25	1,64	14,00	HBM5522	HBM5542	HBM5524	HBM5544	2,20	78
25	3,28	11,77	HBM6522	HBM6542	HBM6524	HBM6544	5,50	90
50	1,64	14,00	HBM5622	HBM5642	HBM5624	HBM5644	2,20	130
50	3,28	11,77	HBM6622	HBM6642	HBM6624	HBM6644	5,50	160
100	3,28	11,77	HBM6722	HBM6742	HBM6724	HBM6744	5,50	240

50 Hz Single Phase								
Tank	Flow at 700 bar	Flow at 50 bar	115V		230 V		Power	Weight
l	l/min	l/min	S/A	D/A	S/A	D/A	kW	kg
5	0,36	4,00	HBM7225	HBM7245	HBM7221	HBM7241	0,75	29
8,5	0,54	5,90	HBM3325	HBM3345	HBM3321	HBM3341	1,10	38
12,5	0,54	5,90	HBM3425	HBM3445	HBM3421	HBM3441	1,10	46
12,5	0,82	8,64	HBM4425	HBM4445	HBM4421	HBM4441	1,50	48

60 Hz Single Phase								
Tank	Flow at 700 bar	Flow at 50 bar	115V		230 V		Power	Weight
l	l/min	l/min	S/A	D/A	S/A	D/A	kW	kg
5	0,36	4,00	HBM7226	HBM7246	HBM7223	HBM7243	0,75	29
8,5	0,54	5,90	HBM3326	HBM3346	HBM3323	HBM3343	1,10	38
12,5	0,54	5,90	HBM3426	HBM3446	HBM3423	HBM3443	1,10	46
12,5	0,82	8,64	HBM4426	HBM4446	HBM4423	HBM4443	1,50	48

**HYDRAULIC ELECTRIC PUMPS (SOLENOID VALVE)**



- ✓ Remote pendant controlled solenoid valves with up, down and emergency stop button.
- ✓ Internal safety valve set at 700 bar to prevent overpressure.
- ✓ External adjustable pressure relief valve.
- ✓ For use with single acting or double acting cylinders for heavy lifting or production applications.
- ✓ Supplied with a 3 metre cable with remote pendant.
- ✓ Options: roll bars, heat exchanger, pressure gauge (glycerine or digital), wheel kit, pedal and push button remote motor control.

NOTE: Pressure gauge is not included.

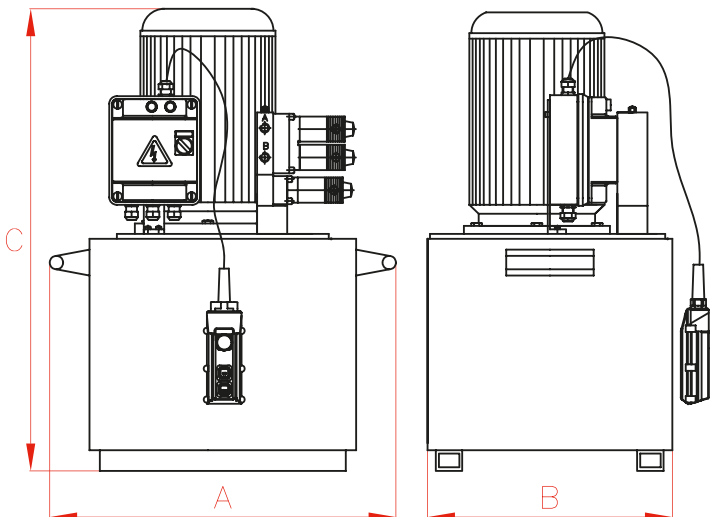

Capacity	A	B	C
l	mm	mm	mm
5	370	230	500
8,5	390	310	525
12,5	410	390	550
25	470	360	670
50	540	415	750
100	830	500	840



**PUMP**  
Accessories



P.96

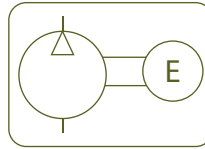

**HYDRAULIC POWERPACKS**



Type

**HBE**

Capacity

**5 - 100 litres**

Max. pressure

**700 bar**

50-60 Hz 3 phase								
Tank	Flow at 700 bar	Flow at 50 bar	230 V		380V/415V		Power	Weight
l	l/min	l/min	S/A	D/A	S/A	D/A	kW	kg
5	0,36	4,00	HBE7262	HBE7272	HBE7264	HBE7274	0,75	27
8,5	0,54	5,90	HBE3362	HBE3372	HBE3364	HBE3374	1,10	35
12,5	0,54	5,90	HBE3462	HBE3472	HBE3464	HBE3474	1,10	43
12,5	0,82	8,64	HBE4462	HBE4472	HBE4464	HBE4474	1,10	45
25	1,64	14,00	HBE5562	HBE5572	HBE5564	HBE5574	2,20	83
25	3,28	11,77	HBE6562	HBE6572	HBE6564	HBE6574	5,56	95
50	1,64	14,00	HBE5662	HBE5672	HBE5664	HBE5674	2,20	135
50	3,28	11,77	HBE6662	HBE6672	HBE6664	HBE6674	5,50	165
100	3,28	11,77	HBE6762	HBE6772	HBE6764	HBE6774	5,50	245

50 Hz Single Phase								
Tank	Flow at 700 bar	Flow at 50 bar	115V		230 V		Power	Weight
l	l/min	l/min	S/A	D/A	S/A	D/A	kW	kg
5	0,36	4,00	HBE7265	HBE7275	HBE7261	HBE7271	0,75	35
8,5	0,54	5,90	HBE3365	HBE3375	HBE3361	HBE3371	1,10	44
12,5	0,54	5,90	HBE3465	HBE3475	HBE3461	HBE3471	1,10	52
12,5	0,82	8,64	HBE4465	HBE4475	HBE4461	HBE4471	1,50	64

60 Hz Single Phase								
Tank	Flow at 700 bar	Flow at 50 bar	115V		230 V		Power	Weight
l	l/min	l/min	S/A	D/A	S/A	D/A	kW	kg
5	0,36	4,00	HBE7266	HBE7276	HBE7263	HBE7273	0,75	35
8,5	0,54	5,90	HBE3366	HBE3376	HBE3363	HBE3373	1,10	44
12,5	0,54	5,90	HBE3466	HBE3476	HBE3463	HBE3473	1,10	52
12,5	0,82	8,64	HBE4466	HBE4476	HBE4463	HBE4473	1,50	64

## HYDRAULIC POWERPACKS HBM, HBE SELECTION TABLES

- ✓ LARZEP 700 bar Electric Hydraulic Powerpacks provide high performance in a compact package with super quiet operation.

The range of powerpacks includes:

1. Manual directional control valves (HBM versions) or remote pendant controlled solenoid valves (HBE versions).
2. Seven different pumps, two speeds, from 0.36 to 3.28 l/min at 700 bar.
3. Six tank sizes from 5 to 100 litre capacity.
4. Eight control valves, 2, 3 and 4 ways and 2 or 3 positions.
5. Single-phase (115V or 230V) or three-phase motor (230V or 400/415V).
6. Options: Remote pendant, oil cooler, roll bar, wheel kit, pedal and glycerine or digital gauge.

The powerpacks are available in configurations to suit single acting or double acting cylinders for heavy lifting or production applications.

### 1. POWERPACK MODEL Build your powerpack using the charts numbered from 2 to 6

HB	1. Operation	2. Pump	3. Tank	4. Valve HBM	4. Valve HBE	5. Motor	6. Options
	<b>M</b> (Manual)	-	-	0	-	1	<b>B</b> Remote Pendant (For HBM)
	<b>E</b> (Solenoid)	-	2	1	-	2	<b>C</b> Roll Bar
		3	3	2	-	3	<b>D</b> Digital Gauge
		4	4	4	-	4	<b>G</b> Glycerine Gauge
		5	5	-	5	5	<b>H</b> Oil cooler
		6	6	-	6	6	<b>P</b> Foot Switch
		7	7	-	7	-	<b>R</b> Wheels
		-	-	8	-	-	
<b>HB</b>	<b>E</b>	<b>3</b>	<b>4</b>	<b>-</b>	<b>7</b>	<b>2</b>	<b>CR</b>

Example



If you need any help ordering a Powerpack please contact our Internal Sales department.

Type: **HBE3472CR**  
1 2 3 4 5 6

- HBE: Hydraulic Powerpack with (E) Solenoid Valve
- 3: 2 speed pump, 5,90 - 0,54 l/min flow
- 4: 12,5 litre tank
- 7: 4/3 valve, double acting
- 2: 3 phase, 230V, 50/60 Hz motor
- CR: with roll bar and wheels



## 2. PUMP MODEL

Pump	No. of speeds	Oil flow (l/min) at low pressure	Oil flow (l/min) at 700 bar	Minimum tank size (l)	3 phase kW	Single phase kW
3	2	5,90	0,54	8,5	1,10	1,10
4	2	8,64	0,82	12,5	1,10	1,50
5	2	14,00	1,64	25	2,20	-
6	2	11,77	3,28	25	5,50	-
7	2	4,00	0,36	5	0,75	0,75

Higher power series 5 and 6 pumps (2,2kW and 5,5kW) are not available in single phase versions.

## 3. TANK MODEL

Tank	Oil effective capacity (l)	Length (mm)	Width (mm)	Height (mm)	Material
2	5	≤370	230	500	Aluminium
3	8,5	≤390	≤310	525	Aluminium
4	12,5	≤410	≤390	550	Aluminium
5	25	470	360	760	Steel
6	50	540	415	750	Steel
7	100	830	500	840	Steel

### Pump / Tank combinations.

Pump / Tank combinations shown in green are standard. Other possible combinations are shown in white or grey.

Standard	5 L	8,5 L	12,5 L	25 L	50 L	100 L
2 Speed Pump/Tank	72	73	74	75		
		33	34	35	36	
			44	45	46	
				55	56	
				65	66	67

Higher power series, 5 and 6 pumps (2.2 kW and 5.5 kW) are not available in single phase versions.

## 4. VALVE MODEL

Valve	Ways / Positions	Function	Single / Double acting	Locking*
0	2/2	Advance-Retract auto	Single	No
1	3/2	Advance-Retract	Single	Yes
2	3/3	Advance-Hold-Retract	Single	Yes
4	4/3	Advance-Hold-Retract	Double	Yes
5	3/2	Advance-Retract	Single	No
6	3/3	Advance-Hold-Retract	Single	No
7	4/3	Advance-Hold-Retract	Double	No
8	4/1	No valve	--	--

\* Locking valves stays in the selected position. For Non locking valves, the handle or push button must be continuously pressed to deliver oil.

## 5. MOTOR MODEL

Motor	Voltage (V)	Phases	Hz
1	230	1	50
2	230	3	50/60
3	230	1	60
4	380/415	3	50/60
5	115	1	50
6	115	1	60

## 6. OPTIONS





## AIR HYDRAULIC PUMPS



Type

**HAZ**

Capacity **14 - 100 litres**

Max. pressure **700 bar**

## AIR DRIVEN HYDRAULIC PUMPS

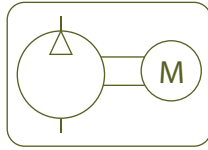

- ✓ Powered by a rotary vane air motor suitable for use in hazardous environments.
- ✓ The manual control valve is easily converted from double acting to single acting operation.
- ✓ Internal safety valve set at 700 bar to prevent overpressure.
- ✓ External adjustable pressure relief valve.
- ✓ Roll bar and wheel kits available as options on request.

Capacity	A	B	C
l	mm	mm	mm
14	368	290	410
25	450	325	540
50	540	415	742
100	830	500	812

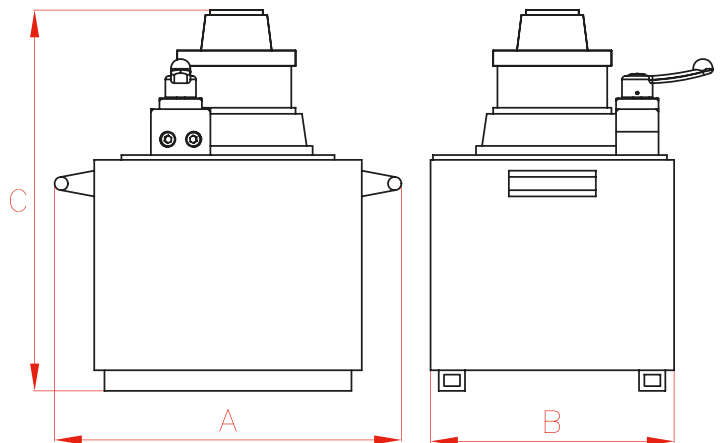

Tank	Flow at 700 bar	Flow at 60 bar	Air consump. at 5,6 bar	Valve Function	Single/A	Double/A	Power	Weight
l	l/min	l/min	l/sec				kW	kg
14	0,36	4	30	Advance-Hold-Retract	HAZ742	HAZ744	3,0	32
25	1,17	-	50	Advance-Hold-Retract	HAZ452	HAZ454	3,7	57
50	2,20	-	80	Advance-Hold-Retract	HAZ562	HAZ564	6,6	109
100	2,20	11*	80	Advance-Hold-Retract	HAZ872	HAZ874	6,6	184

\* Flow at 100 bar



PETROL HYDRAULIC PUMPS

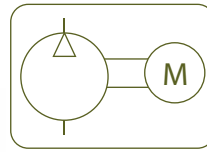

Type **HAG**

Capacity **14 - 50 litres**

Max. pressure **700 bar**

- ✓ Powered by a gasoline engine. For operation in remote locations where electric supply is not available.
- ✓ The manual control valve is easily converted from double acting to single acting operation.
- ✓ Internal safety valve set at 700 bar to prevent overpressure.
- ✓ External adjustable pressure relief valve.
- ✓ Roll bar and wheel kits available as options on request.

Capacity	A	B	C
l	mm	mm	mm
14	368	290	665
25	450	325	760
50	540	415	860

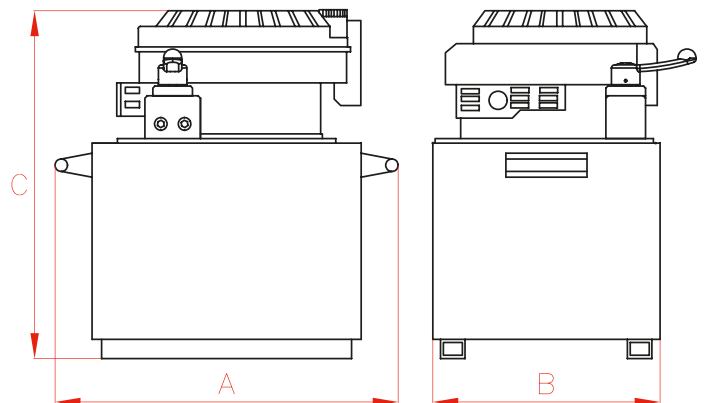

Tank	Flow at 700 bar	Flow at 60 bar	Valve Function	Single/A	Double/A	Power	Weight
l	l/min	l/min				kW	kg
14	0,36	4	Advance-Hold-Retract	<b>HAG742</b>	<b>HAG744</b>	3,6	36
25	0,36	4	Advance-Hold-Retract	<b>HAG752</b>	<b>HAG754</b>	3,6	60
50	0,36	4	Advance-Hold-Retract	<b>HAG762</b>	<b>HAG764</b>	3,6	93

## ACCESSORIES FOR POWERPACKS

### B Remote Pendant



- ✓ With 3 metre long cable.
- ✓ For the remote operation of the motor in HBM series, 'ON' button starts the motor and it stops when the button is released.
- ✓ HBE series are supplied with the remote pendant as standard, with up, down and emergency stop button.
- ✓ Remote pendant is not available for HAG and HAZ.

### H Oil Cooler



- ✓ It is used when the powerpack is used continuously.
- ✓ Stabilizes oil viscosity.

### C Roll Bar



- ✓ Protects pump and its components: motor, valves, etc
- ✓ For easy portability.
- ✓ Different sizes available.



## R Wheel Kit



- ✓ Makes powerpacks easy to move.
- ✓ Two wheels supplied with brake.

## P Pedal



- ✓ Optional instead of remote pendant.
- ✓ With 3 metre long cable.
- ✓ For the remote operation of the motor in HBM series.
- ✓ For the remote operation of the movements in HBE series.

## D Digital Gauge



- ✓ Excellent stability and accuracy:
- ✓  $\pm 0,1-0,5$  % Full Scale (FS)
- ✓ For reliable pressure measurement.
- ✓ Digital pressure measurement and back-lit display.
- ✓ Easy operation.
- ✓ Pressure range: 0-1000 bar.

**SPLIT-FLOW POWERPACKS**

- ✓ Simultaneous lifting system to power 4 or 8 single or double acting cylinders.
- ✓ Simultaneous lifting with less than 4% flow difference between outlets.
- ✓ Manual directional control valves (HFM versions) or remote pendant controlled solenoid valves (HFE versions).
- ✓ Suitable for most of the applications where a uniform lifting is required.
- ✓ HFE solenoid valve powerpacks are supplied with a remote pendant with 5 metre cable.
- ✓ Remote pendant allows independent control of the lifting or lowering.
- ✓ Options: roll bars, oil cooler, wheel kit and remote control, to motor control (HFM).

**SPLIT-FLOW**  
Accessories

P.96







HFE

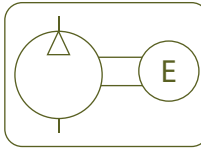

Type **HFM HFE**

Capacity **100 - 150 litres**

Max. pressure **700 bar**

**AZ5255**  
Single Way Flow Regulating Valve



P.123

**AZ3**  
Coupler 3/8"-18 NPT



P.114

**AZ8 - AZ9**  
Directional control valves



P.122

**Remote Pendant in HFE**

- ✔ Allows the individual or simultaneous movement of each cylinder when lifting or lowering.
- ✔ Advance/retract switch selects the position of the solenoid valves.
- ✔ Individual buttons for each cylinder to operate them independently or at the same time.
- ✔ Simultaneous button moves all the jacks at the same time.
- ✔ To improve the control over lowering of the cylinders it is highly recommended to use AZ5255 lowering valves.
- ✔ To make the retraction of single acting spring return cylinders easier, once the lifting is completed and the cylinders are not under load a switch in the electric box allows automatic retraction of the cylinder.



**HFM (MANUAL VALVE) / HFE (SOLENOID VALVE)**

380-415V / 50-60 Hz / 3 phase							
Outlets	Tank	Flow at 700 bar	Manual Valve HFM		Solenoid Valve HFE		Power
No.	l	l/min	Single/A	Double/A	Single/A	Double/A	kW
4	100	0,4	HFM46724	HFM46744	HFE46764	HFE46774	3,0
		0,9	HFM47724	HFM47744	HFE47764	HFE47774	5,5
		2,0	HFM49724	HFM49744	HFE49764	HFE49774	11,0
	150	0,4	HFM46824	HFM46844	HFE46864	HFE46874	3,0
		0,9	HFM47824	HFM47844	HFE47864	HFE47874	5,5
		2,0	HFM49824	HFM49844	HFE49864	HFE49874	11,0
8	150	1,3	HFM88824	HFM88844	HFE88864	HFE88874	15,0

 Available 230V - 3 phase as special

## MODULAR HAND PUMPS



Type

**WI**

Capacity

-

Max. pressure

40 - 700 bar

## MODULAR HAND PUMPS

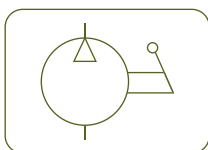

- ✓ Wide range with different working pressures.
- ✓ Lightweight with tapped holes in the base for easy mounting.
- ✓ All models are black nitrided.
- ✓ Designed for use with external reservoirs.
- ✓ Operating lever included.
- ✓ Tank is not included.

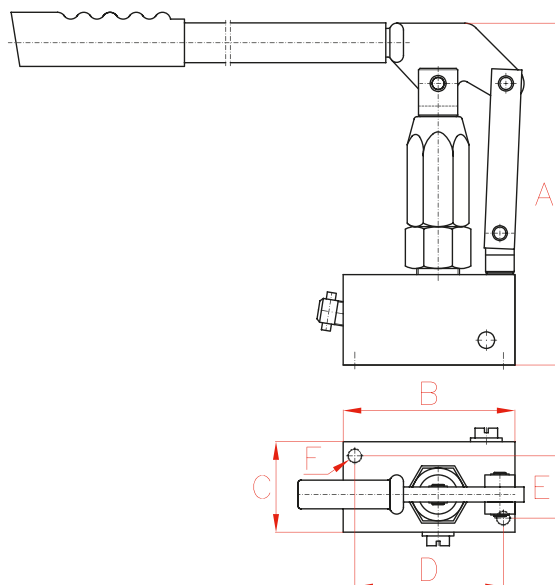

Working Pressure	Model	Max. Pressure	Piston ø	Oil per Stroke	Port Size	A	B	C	D	E	F	Weight
bar	LARZEP	bar	mm	cm <sup>3</sup>	NPT	mm	mm	mm	mm	mm	UNC	kg
700	<b>WI1400</b>	1.400	10	3	3/8"-18NPT	230	114	57	98,5	41,3	3/8"-16UNC	5,3
400	<b>WI700</b>	700	13	4	3/8"-18NPT	230	114	57	98,5	41,3	3/8"-16UNC	5,3
200	<b>WI210</b>	300	19	10	3/8"-18NPT	230	114	57	98,5	41,3	3/8"-16UNC	5,3
100	<b>WI100</b>	200	26	18	3/8"-18NPT	230	114	57	98,5	41,3	3/8"-16UNC	5,7
40	<b>WI040</b>	80	38	36	3/8"-18NPT	230	114	57	98,5	41,3	3/8"-16UNC	7,0



Always read the safety instructions.

**BATTERY POWERED PORTABLE HYDRAULIC PUMP**



Type	<b>HAB</b>
Capacity	2,3 litres
Max. pressure	700 bar

HAB PUMPS

- ✓ 2,3 litre tank.
- ✓ Internal safety valve set at 700 bar to prevent overpressure.
- ✓ 3/2 valve with load holding position.
- ✓ Lightweight and easy portability.
- ✓ For use with cutters and crimping tools.
- ✓ Supplied with 2 batteries, 230V charger and a metal box.

AP2 Hoses



P.112

Oil Capacity	Flow at 700 bar	Model	Voltage	Battery	Length	Width	Height	Weight
l	l/min	LARZEP	V	Ah	mm	mm	mm	kg
2,3	0,16	<b>HAB1102</b>	18	4	220	170	300	8,5

Battery	Voltage	Battery Life	Charger		Charging Temperature
Li-ion		Al/Steel Cable 570/40	Charging Time	Input	Output
Ah	V	Cuts	Minutes	V (AC) / Hz	V (DC) / A
4	18	70	40	220-240 / 50-60	18 / 4,0
					-10 to 40

## AIR DRIVEN HYDROTEST PUMPS



- ✓ 10 Models Available, from 70 bar to 2.900 bar.
- ✓ Engineered and designed for easy operation.
- ✓ Compact and lightweight steel frame for full protection and handling.
- ✓ Fully integrated, protected and calibrated pressure gauge.
- ✓ Clearly labelled controls for improved safety.
- ✓ Supplied with air inlet connector, air filter, air pressure regulator, air lubricator, air pressure gauge, air pressure limit valve, pump on/off control, oil pressure gauge.
- ✓ All pumps can work with water or oil.
- ✓ All pumps supplied complete with a full test certificate as standard.
- ✓ High pressure fittings and any length of high pressure hose available from stock.

Hydraulic Pressure Gauge: Dual scale bar/psi

Oil / Water Reservoir: 7 litres

Working Air Pressure: 1,7 to 6,9 bar

Air Inlet Port: 1/2" NPTF Female

Air Consumption: 0,79 m<sup>3</sup>/min

Sound Level: 90 dBA

Weight: 30 kg





Free standing Chart recorders:  
HAPR19, HAPR28



Options: **Chart recorders** Integral or free standing; Chart recorder pens and charts; Stroke counter; Stainless steel framework; External connection to liquid supply to increase available fluid during testing; USB connection for laptop including software.

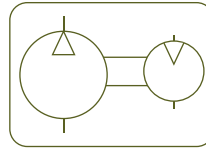

Type	<b>HAP</b>
Capacity	7 litres
Max. pressure	70 - 2.900 bar

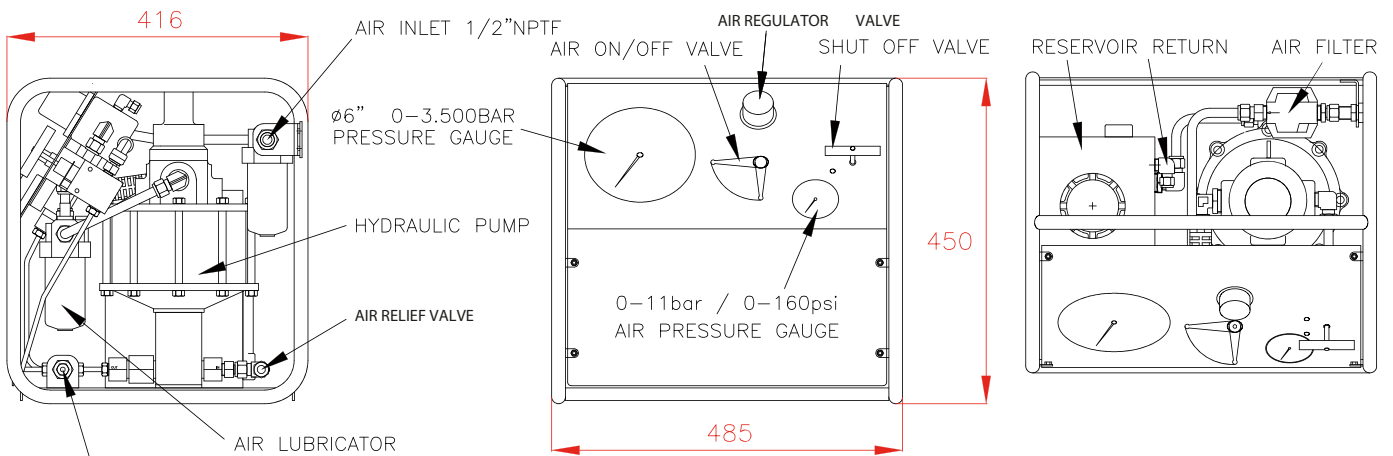

OUTLET PORT\*

\* 3/8" NPTF FROM 70 TO 740 BAR

\* 9/16"-18UNF FROM 1300 TO 2900 BAR

### HYDROTEST PUMPS

Hydrotest Pump	Maximum Hydraulic Pressure (bar)			Flow (l/min)			Outlet Port
	Air 6.9 bar	Air 5.1 bar	Air 4.1 bar	20% Max. P	50% Max. P	80% Max. P	
LARZEP							Female
HAP0070	70	55	40	16,2	11,0	3,7	3/8" NPT
HAP0130	130	100	80	8,5	6,0	3,9	3/8" NPT
HAP0180	180	150	100	6,1	4,7	2,6	3/8" NPT
HAP0250	250	200	150	4,1	3,1	2,0	3/8" NPT
HAP0400	400	320	240	2,6	1,8	1,2	3/8" NPT
HAP0740	740	600	440	1,2	0,9	0,6	3/8" NPT
HAP1300	1.300	1.000	770	0,65	0,5	0,3	9/16"-18UNF
HAP1900	1.900	1.500	1.100	0,4	0,3	0,2	9/16"-18UNF
HAP2900	2.900	2.300	1.800	0,25	0,2	0,1	9/16"-18UNF

### BOLT TENSIONER PUMP

Bolt Tensioner Pump	Maximum Hydraulic Pressure (bar)			Flow (l/min)			Outlet Port
	Air 6.9 bar	Air 3.5 bar	Air 1.7 bar	20% Max. P	50% Max. P	80% Max. P	
LARZEP							Coupler
HAP2900BT	-	1.500	760	0,3	0,2	0,1	AZ3341



## HYDROTEST HAND PUMPS



- ✓ Tanks from 12 to 100 litres.
- ✓ 13 models available, from 25 bar to 1.300 bar.
- ✓ Engineered and designed for easy operation.
- ✓ WAP models with cast iron or mild steel frame.
- ✓ WIP models with stainless steel frame. Used by the Chemical industry or when aggressive liquids are used.
- ✓ Supplied with pressure gauge and control valve.
- ✓ All pumps can work with water.
- ✓ Pressure gauge: Dual scale bar / psi. / Class 1.6 up to 200 bar and Class 1.0 from 300 to 1.300 bar.

### WAP0025, WAP0035, WAP0045, WAP0050, WAP0100

- ✓ Manufactured in cast iron for heavy duty and professional uses.
- ✓ Supplied with pressure gauge ø60 mm and double control valve, except model WAP0035 that is supplied with single control valve.



### WAP0300, WAP0500, WAP1000, WAP1300

- ✓ Hand pumps used for high pressure hydrostatic tests.
- ✓ 2 stages pumps with 100 litres tank manufactured in mild steel.
- ✓ Supplied with pressure gauge ø100 mm and control valve.



**WAP0040, WAP0070, WIP0040, WIP0200**

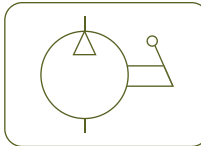

- ✓ Lightweight hand pumps manufactured in mild steel and stainless steel for use on bench in workshop hydrostatic tests.
- ✓ Supplied with pressure gauge ø60 mm, control valve and 13 litre tank.
- ✓ WIP0040 and WIP0200 models have stainless steel tanks. Used by the Chemical industry or when aggressive liquids are used.
- ✓ WAP0040 and WIP0040 pumps are supplied with 1.5 metre hose. These pumps are normally used on plumbing for heating plant testing.



Type **WAP - WIP**

Capacity **12 - 100 litres**

Max. pressure **25 - 1.300 bar**

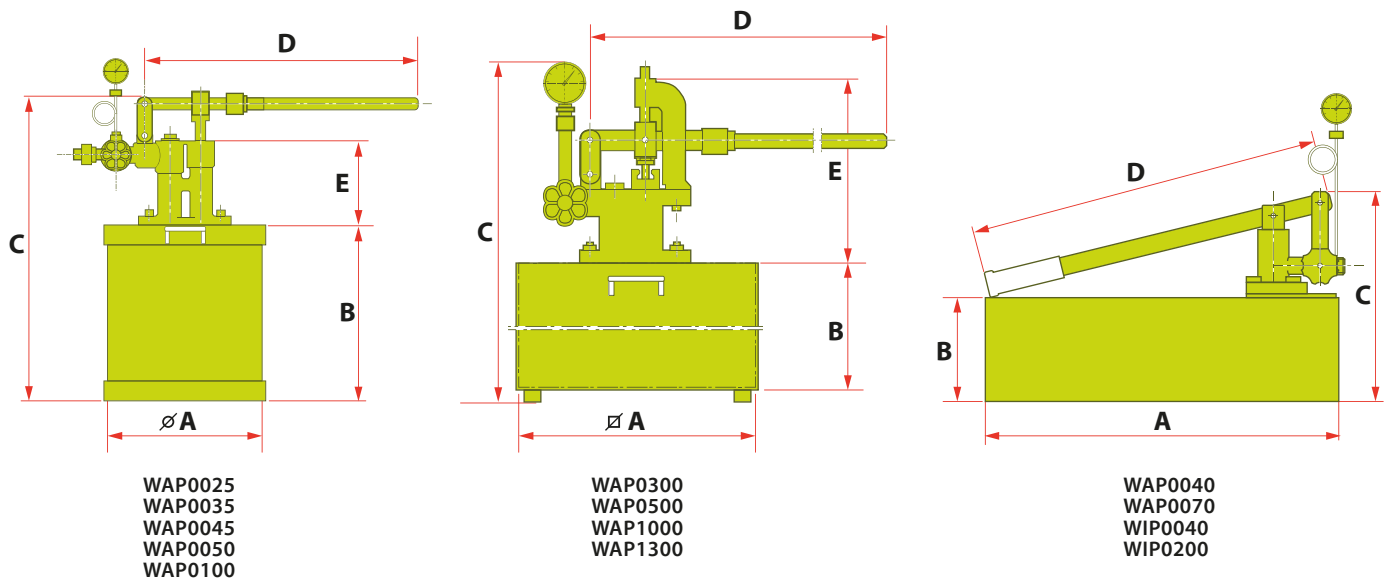

**CAST IRON AND MILD STEEL PUMPS - WAP**

Hydrotest Pump	Max. Pressure	Capacity	Flow / stroke	Material	Outlet Port	A	B	C	D	E	Weight
LARZEP	bar	litres	cc		BSP	mm	mm	mm	mm	mm	kg
WAP0025	25	12	11	Cast iron	3/8" Male	ø255	272	450	420	120	10
WAP0035	35	12	14	Cast iron	1/2" Female	ø255	272	430	350	100	8
WAP0045	45	21	14	Cast iron	3/8" Male	ø260	397	558	420	150	12
WAP0050	50	38	20	Cast iron	3/8" Male	ø390	397	558	683	150	22
WAP0100	100	38	20	Cast iron	3/8" Male	ø390	397	558	683	150	22
WAP0040	40	13	18	Mild steel	1/2" Male	500 x 190	140	280	500	-	8
WAP0070	70	13	11	Mild steel	1/2" Female	500 x 190	140	295	700	-	9
WAP0300	300	100	18 / 3,5	Mild steel	1/2" Female	500 x 500	400	800	800	400	54
WAP0500	500	100	18 / 3,5	Mild steel	1/2" Female	500 x 500	400	800	800	400	54
WAP1000	1.000	100	18 / 3,5	Mild steel	1/2" Female	500 x 500	400	800	1.000	400	60
WAP1300	1.300	100	18 / 3,5	Mild steel	1/2" Female	500 x 500	400	800	1.000	400	60

**STAINLESS STEEL PUMPS - WIP**

Hydrotest Pump	Max. Pressure	Capacity	Flow / stroke	Material	Outlet Port	A	B	C	D	Weight
LARZEP	bar	litres	cc		BSP	mm	mm	mm	mm	kg
WIP0040	40	13	18	Bronze & SS	1/2" Male	500 x 190	140	280	500	10
WIP0200	200	13	18	SS	1/2" Female	500 x 190	140	295	700	8

**ELECTRIC HYDROTEST PUMPS**

HEP0020

- ✓ 6 models available, from 20 bar to 500 bar.
- ✓ Engineered and designed for easy operation.
- ✓ HEP0050D model, without tank.
- ✓ HEP0500 model, without tank and on trolley.
- ✓ Supplied with pressure gauge and control valve.
- ✓ HEP0180 pump supplied with double control valve.
- ✓ All pumps, except HEP0180 model, are supplied with 1.5 metre hose.
- ✓ All pumps can work with water.
- ✓ Pressure gauge: Dual scale bar / psi. Class 1.6.



HEP0120 - HEP0250



HEP0050D



**HEP0020**

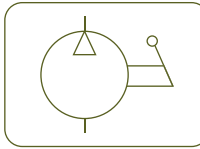

- ✓ Working pressure: **20 bar**.
- ✓ Electric pump for filling, pouring, pressurizing and testing water systems and other non-oily liquids, such as antifreeze fluids. It can be connected directly to the water mains or tank. Maximum suction height 3 metres.
- ✓ Body of the pump made of anodized aluminium.
- ✓ Supplied with 1.5 metres hose, pressure gauge ø60 mm and control valve.

**HEP0050D**

- ✓ Working pressure: **50 bar**.
- ✓ Electric pump for filling, pouring, pressurizing and testing water systems and other non-oily liquids, such as antifreeze fluids.
- ✓ Supplied without tank. To be connected directly to the water mains.
- ✓ Lightweight and strong construction. Manufactured with anticorrosive and wear and tear resistant materials.
- ✓ Supplied with 1.5 metre hose, pressure gauge and control valve.

**HEP0120, HEP0180, HEP0250**

- ✓ Working pressure: **120, 180 and 250 bar**.
- ✓ Electric pump with 100 litre tank used for filling and testing hydraulic systems in industrial plants.
- ✓ HEP0120 and HEP0250 models are supplied with 1.5 metre hose, pressure gauge and control valve.
- ✓ HEP0180 model is supplied with pressure gauge and double control valve. Hose is not supplied as standard.
- ✓ Supplied with a second gauge to regulate the pressure before filling the system.

**HEP0500**

- ✓ Working pressure: **500 bar**.
- ✓ Electric pump designed for filling, pressurizing and testing hydraulic and steam systems, in chemical, electric and pharmaceutical industry.
- ✓ Supplied without tank. To be connected directly to the water mains.
- ✓ During testing the pump can be physically disconnected from the circuit.
- ✓ Mounted on trolley with wheels and hooks for lifting the pump with straps.
- ✓ Control panel with automatic thermic protection and emergency stop button.
- ✓ Pressure can be set before the test, to avoid overpressure on the system.



Type	<b>HEP</b>
Capacity	<b>0 - 100 litres</b>
Max. pressure	<b>20 - 500 bar</b>



Hydrotest Pump	Max. Pressure	Capacity	Flow	Outlet Port	Motor	Dimensions	Power	Weight
LARZEP	bar	litres	l/min	BSP	V/Hz	mm	kW	kg
HEP0020	20	12	15	1/2" BSP Female	230V / 50 Hz	250 x 530 x 410	0,75	17
HEP0050D	50	-	8	1/2" BSP Female	230V / 50 Hz	200 x 440 x 310	1,75	16
HEP0120	120	100	4	1/2" BSP Female	230-400V / 50 Hz	500 x 500 x 750	1,50	66
HEP0180	180	100	13	3/8" BSP Male	400V / 50 Hz	500 x 500 x 750	5,00	66
HEP0250	250	100	13	1/2" BSP Female	400V / 50 Hz	500 x 500 x 750	6,35	76
HEP0500	500	-	15	3/8" BSP Male	400V / 50 Hz	975 x 570 x 600	15,00	135

## TORQUE WRENCH PUMPS



- ✓ Tanks from 5 to 14 litres.
- ✓ Push button controlled solenoid valves.
- ✓ Internal safety valve set at 700 bar to prevent overpressure.
- ✓ Precision adjustable pressure regulating valve.
- ✓ 4 way / 2 position valve.
- ✓ For use with double acting torque wrenches only.
- ✓ Supplied with a 3 metre cable with remote pendant.
- ✓ Easy to operate: Pressing the button advances the tool and when releasing it retracts automatically.
- ✓ Option: Oil cooler. Add 'H' to the reference.



**AZ3**  
Coupler 3/8"-18 NPT included.



P.114

**AR2**  
Hoses



P.112





Couplers

Model	Coupler	Thread	Pressure
LARZEP	Type	NPT	bar
AZ3325	Male	Female 3/8"-NPT	1.000
AZ3326	Male	Male 1/4"-NPT	1.000
AZ3341	Female	Female 3/8"-NPT	1.000
AZ3346	Female	Male 1/4"-NPT	1.000

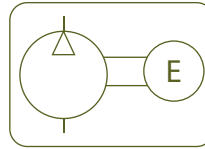

Type **HAT**

Capacity 5- 14 litres

Max. pressure 700 bar

AR, Twin Hoses

Int.	Hose 1	Hose 2	Pressure	Length		
	End	End		3 m	6 m	10 m
6,4	2 x AZ3341	2 x AZ3325	700	AR2030G2	AR2060G2	AR2100G2

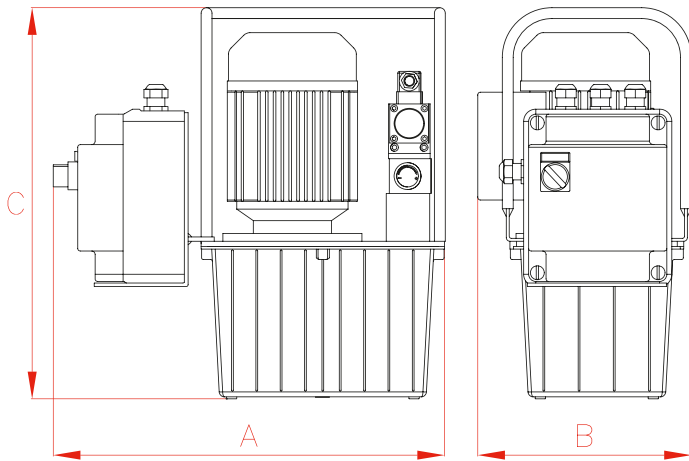

Capacity	A	B	C
l	mm	mm	mm
5	460	280	540
10	500	350	600
14	540	368	615

Tank	Flow at 700 bar	Flow at 60 bar	Valve	50 Hz Single Phase		60Hz Single Phase		Power	Weight
				l/min	l/min	ways/positions	230 V		
5	0,36	4	4/2	HAT7291	HAT7295	HAT7293	HAT7296	0,75	35
10	0,36	4	4/2	HAT7391	HAT7395	HAT7393	HAT7396	0,75	41
14	0,36	4	4/2	HAT7491	HAT7495	HAT7493	HAT7496	0,75	45

Tank	Flow at 700 bar	Flow at 60 bar	Valve	50/60 Hz 3 Phase		Power	Weight
				l/min	l/min		
5	0,36	4	4/2	HAT7292	HAT7294	0,75	32
10	0,36	4	4/2	HAT7392	HAT7394	0,75	38
14	0,36	4	4/2	HAT7492	HAT7494	0,75	42



## ACCESSORIES









**LARZEP** offers a wide range of accessories to optimize our products performance: Hoses, Couplers, Tilting saddles, Hollow saddles, Flow control valves, Fittings and Manifolds, Pressure gauges and Directional control valves are available as standard.

- ✓ Wide range of standard hoses up to 100 metres and 720 bar working pressure.  
Available hoses for 1.100 and 1.800 bar working pressure and Twin hoses for torque wrenches.
- ✓ Low flow and high flow quick couplers available as standard.  
Working pressure: 700 bar, 1.000 bar and 1.500 bar.
- ✓ Wide range of Flow control valves: Snubber valves, Flow regulating valves with 2 or 4 outlets, Manually operated check valve, Single way flow regulating valve, Check valve, Pressure relief valve and Pilot operated check valve.
- ✓ Tilting saddles highly recommended for side load application.  
Hollow saddles used in hollow piston cylinders specially in pulling and tensioning operations.
- ✓ Wide range of fittings and manifolds for multiple applications.
- ✓ Glycerine filled pressure gauges for monitoring working pressure and force.  
Available digital pressure gauges and pressure transducers.
- ✓ 3- or 4- ways directional control valves for single and double acting cylinders, suitable for remote operation.



# ACCESSORIES



Models	Accessories type		Page
AP - AR	Hydraulic Hoses		112
AZ89	Hydraulic Oil		113
AZ3	Hydraulic Couplers		114
AZ5	Flow Control Valves		116
AZ04 - AZ05	Saddles		118
AZ1	Fittings and Manifolds		120
AZ8 - AZ9	Directional Control Valves		122
AV-AVD AT-AY	Pressure Gauges		123

**HYDRAULIC HOSES**

- ✓ 4:1 Safety Factor.
- ✓ Wide range of standard hoses. Hoses can be supplied in any length on request.
- ✓ Rubber Guard on both ends.
- ✓ 3/8"-NPT thread on each end. Can be supplied with couplers on one or both ends.
- ✓ Internal Diameter 6,4mm; Oil Capacity: 35 cm<sup>3</sup> per metre.
- ✓ Internal Diameter 9,5mm; Oil Capacity: 75 cm<sup>3</sup> per metre.
- ✓ Twin hoses for torque wrenches available. AR model.
- ✓ 1.100, 1.800 and 2.800 bar working pressure hoses available.
- ✓ Minimum Bending radius: 80 mm.

**WARNING**

**Never disconnect the hose when the system is pressurized.  
Never exceed the maximum working pressure of the hose.**



Apply 2 rounds of Teflon around all 3/8" NPT threads of the system, in the thread direction, leaving the first thread uncovered to prevent the tape breaking and entering the hydraulic system. Torque: 80 Nm.



HYDRAULIC HOSES



Type **AP - AR**

Capacity **0,8 - 100 m length**

Max. pressure **700 - 1.800 bar**

**MAXIMUM WORKING PRESSURE 700 / 720 BAR**

Int. ø mm	End		Pressure bar	Length						
	1	2		0,8 m	1,5 m	2 m	3 m	4 m	6 m	10 m
6,4	3/8"-NPT	3/8"-NPT	720	AP2008	AP2015	AP2020	AP2030	AP2040	AP2060	AP2100
6,4	3/8"-NPT	AZ3120	720	AP2008G	AP2015G	AP2020G	AP2030G	AP2040G	AP2060G	AP2100G
6,4	AZ3120	AZ3120	720	AP2008G2	AP2015G2	AP2020G2	AP2030G2	AP2040G2	AP2060G2	AP2100G2
9,5	3/8"-NPT	3/8"-NPT	700	AP4008	AP4015	AP4020	AP4030	AP4040	AP4060	AP4100
9,5	3/8"-NPT	AZ3120	700	AP4008G	AP4015G	AP4020G	AP4030G	AP4040G	AP4060G	AP4100G
9,5	AZ3120	AZ3120	700	AP4008G2	AP4015G2	AP4020G2	AP4030G2	AP4040G2	AP4060G2	AP4100G2

**MAXIMUM WORKING PRESSURE : 700 BAR - TWIN HOSES AR, FOR TORQUE WRENCHES**

Int. ø mm	End		Pressure bar	Length							
	Hose 1	Hose 2		0,8 m	1,5 m	2 m	3 m	4 m	6 m	8 m	10 m
6,4	2 x 3/8"-NPT	2 x 3/8"-NPT	700	AR2008	AR2015	AR2020	AR2030	AR2040	AR2060	AR2080	AR2100

**MAXIMUM WORKING PRESSURE 1.100 BAR**

Int. ø mm	End		Pressure bar	Length							
	1	2		0,8 m	1,5 m	2 m	3 m	4 m	6 m	8 m	10 m
6,4	3/8"-NPT	3/8"-NPT	1.100	AP3008	AP3015	AP3020	AP3030	AP3040	AP3060	AP3080	AP3100

**MAXIMUM WORKING PRESSURE 1.800 BAR**

Int. ø mm	End		Pressure bar	Length							
	1*	2*		0,8 m	1,5 m	2 m	3 m	4 m	6 m	8 m	10 m
6,4	1/4"-BSP	1/4"-BSP	1.800	AP5008	AP5015	AP5020	AP5030	AP5040	AP5060	AP5080	AP5100

\*Cone 120°

**HYDRAULIC OIL**

Model	Capacity (l)	For use with
AZ8901	5	Hand Pumps, Bottle Jacks
AZ8902	5	Powerpacks



## HYDRAULIC COUPLERS



- ✓ Low flow and high flow couplers, from 6 to 40 litres/min.
- ✓ 700 and 1.000 bar couplers have 3/8"-18 NPT thread. 1.500 bar couplers have 1/4"-BSP thread.
- ✓ Male and Female couplers can be supplied separately.
- ✓ Steel dust cup available for AZ3120, AZ3140 and AZ3141 couplers.
- ✓ AZ3321, AZ3322, AZ3324, AZ3325, AZ3341, AZ3344 and AZ3345: ball quick couplers to guarantee easy and quick connection.
- ✓ AZ3120, AZ3140 and AZ3141: standard high flow couplers.
- ✓ AZ3220 and AZ3240: low flow couplers. Only used in Maintenance Sets.
- ✓ All standard cylinders are supplied with AZ3140 female coupler.
- ✓ All cutters are supplied with AZ3321 male ball coupler.



### WARNING

**Never disconnect the hose when the system is pressurized.  
Never exceed the maximum working pressure of the hose.**



Apply 2 rounds of Teflon around all 3/8" NPT threads of the system, in the thread direction, leaving the first thread uncovered to prevent the tape breaking and entering the hydraulic system. Torque: 80 Nm.





**HIGH FLOW COUPLERS 700 BAR**

**AZ3120**

**AZ3140**

**AZ3141**

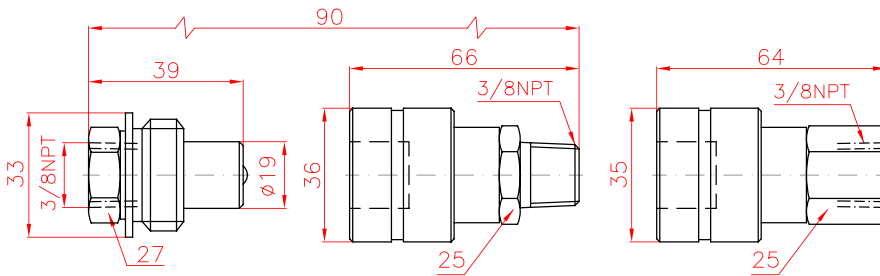

**LOW FLOW COUPLERS 700 BAR**

**AZ3220**

**AZ3240**

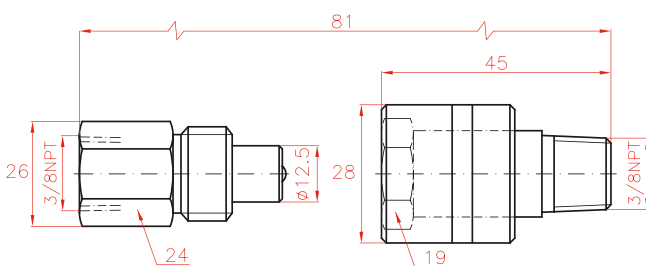

**1.000 BAR BALL COUPLERS**

**AZ3321**

**AZ3341**

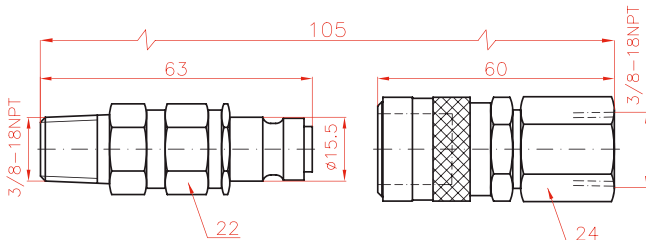

**AZ3325**

**AZ3345**

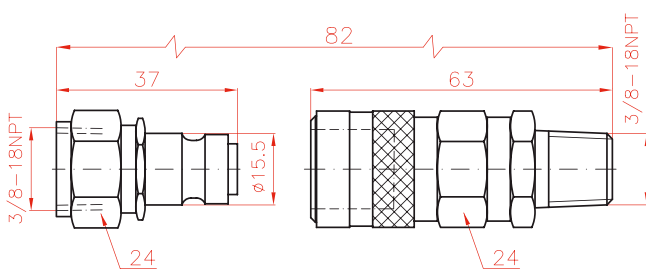

**1.500 BAR BALL COUPLERS**

**AZ3322**

**AZ3324**

**AZ3344**

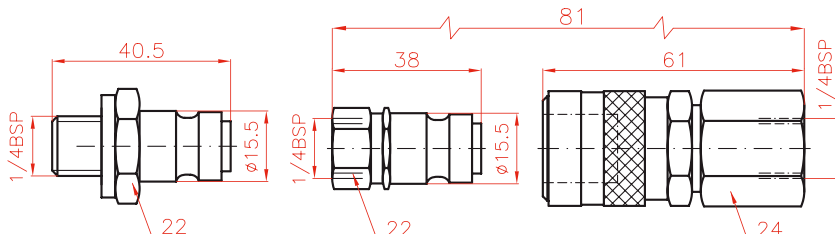

Ref. AZ3322 without valve.

Type **AZ3**

Capacity **6 - 40 l/min**

Max. pressure **700 - 1.500 bar**

Steel dust cup available:

AZ3144 for female couplers AZ3140 and AZ3141  
AZ3124 for male coupler AZ3120



Plastic dust cup AZ3103 available

to suit AZ3120, AZ3140 and AZ3141 couplers



Flow l/min	Coupling	Model LARZEP	Thread	Pressure bar
40	Male	AZ3120	Female 3/8"NPT	700
	Female	AZ3140	Male 3/8"NPT	700
	Female	AZ3141	Female 3/8"NPT	700
7	Male	AZ3220	Female 3/8"NPT	700
	Female	AZ3240	Male 3/8"NPT	700
6	Male	AZ3321	Male 3/8"NPT	1.000
	Male	AZ3325	Female 3/8"NPT	1.000
	Female	AZ3341	Female 3/8"NPT	1.000
	Female	AZ3345	Male 3/8"NPT	1.000
6	Male	AZ3322	Male 1/4"BSP*	1.500
	Male	AZ3324	Female 1/4"BSP*	1.500
	Female	AZ3344	Female 1/4"BSP*	1.500

\*Cone 120°

AZ3321, AZ3322, AZ3324 and AZ3325 male couplers are connectable with AZ3341, AZ3344 and AZ3345 female couplers



**FLOW CONTROL VALVES**



Model	SNUBBER VALVE	Symbol	
AZ5121	Used for flow control and load holding when closed. Also suitable for use as a gauge snubber.		

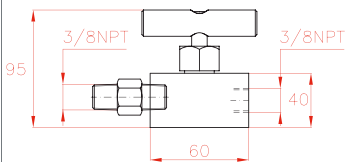

Model	MANIFOLD WITH FLOW REGULATING VALVE, 2 OUTLETS	Symbol	
AZ5122	Used for flow control of two outlets from one pressure source.		

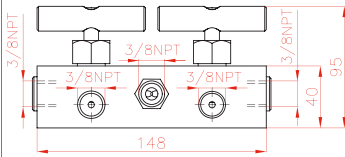

Model	MANIFOLD WITH FLOW REGULATING VALVE, 4 OUTLETS	Symbol	
AZ5124	Used for flow control of four outlets from one pressure source.		

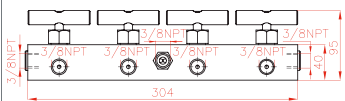

- ✓ All flow and pressure control valves are designed for 700 bar working pressure.
- ✓ All valves have 3/8"-NPT pressure ports to prevent leakage.



Type	<b>AZ5</b>
Capacity	-
Max. pressure	<b>700 bar</b>

Model	MANUALLY OPERATED CHECK VALVE	Symbol	
AZ5200	<p>When open, allows oil flow in both directions.</p> <p>When closed, allows oil flow in one direction only, holding the load in the other one.</p>		

Model	SINGLE WAY FLOW REGULATING VALVE	Symbol	
AZ5255	<p>Similar to AZ5200, allows free oil flow in one direction and in the other, flow can be regulated or completely closed.</p>		

Model	CHECK VALVE	Symbol	
AZ5500	<p>Allows oil flow in one direction only.</p>		

Model	PRESSURE RELIEF VALVE	Symbol	
AZ5600	<p>Regulates the pressure in the hydraulic circuit. From 50 to 700 bar. Supplied with a 0.9 metre return line hose kit.</p>		

Model	PILOT OPERATED CHECK VALVE	Symbol	
AZ5700	<p>Load holding valve used with double-acting cylinders which is released by pilot pressure from the return line.</p>		

AZ5 ACCESSORIES

**SADDLES**



**TILTING SADDLES AZ04**

- ✓ Recommended for high side load applications.
- ✓ These saddles allow up to 5° tilt angle.
- ✓ Push-in or threaded to suit different cylinder models.

**AZ04 TILTING SADDLES**

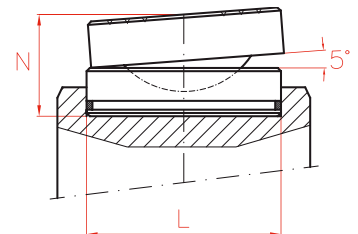

**HOLLOW SADDLES AZ05**

- ✓ Used in hollow piston cylinders.
- ✓ Especially used in pulling operations and as support.
- ✓ These saddles can be plain, threaded or solid.

**AZ05 HOLLOW SADDLES**

Standard Plain

Optional Internal Thread

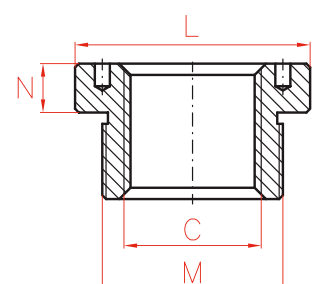
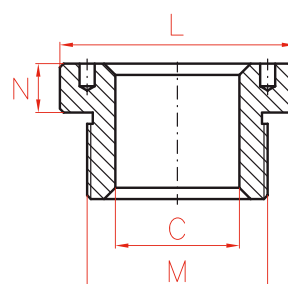

SADDLES



Type **AZ04 - AZ05**

Capacity -

Max. pressure **700 bar**

**THREADED TILTING SADDLES**

Model	L	M	N	E	Weight	Cylinder Model
LARZEP	mm		mm	mm	kg	
AZ0420	28	1"-8	29	43	0,2	SM010-D010
AZ0423	35	1"-8	29	49	0,3	SM015-D020
AZ0421	45	1 1/2"-16	28	50	0,4	SM023-SM030-D030
AZ0422	61	1 3/4"-12	38	58	0,7	D050-D075-D100
AZ0424	88	2 1/2"-12	47	82	2,5	D150
AZ0425	111	2 1/2"-12	52	107	4,5	D200
AZ0431	34	M28x1,5	29	44	0,3	SH012
AZ0432	48	1 9/16"-16	29	46	0,5	SH022
AZ0433	55	1 13/16"-16	37	57	0,6	SH030-SAH030-DH030-DAH030
AZ0434	80	2 3/4"-16	47	67	2,3	SH060-SAH060-DH060-DAH060
AZ0435	116	2 1/2"-12	52	76	5,5	SH100-SAH100-DH100-DAH100

**AZ04 THREADED TILTING SADDLES**

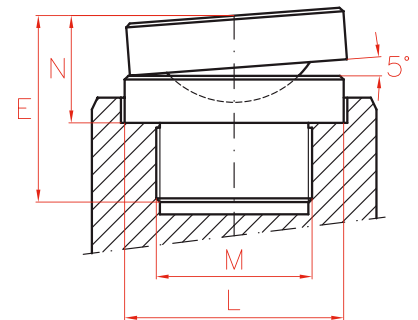

**TILTING SADDLES**

Model	L	N	Weight	Cylinder Model
LARZEP	mm	mm	kg	
AZ0401	45	36	0,4	SAM023-SAM030-SP030-SMP030-STR030-SAT030-SATM030
AZ0402	61	39	0,8	SM050-SM075-SAM050-SP050-SMP050-SX050-SX075-STR050-SAT050-SATM050-DDA050-DDA075-DDR050
AZ0404	88	47	2,2	SM100-SM140-SAM100-SAM140-SP100-SMP100-SPR140-SX100-SX150-STR100-STR140 SAT100-SAT140-SATM100-SATM140-SSR140-DDA100-DDA140-DDR100-DDR140
AZ0405	111	52	4,0	SM220-SAM200-SPR220-STR220-SAT200-SATM200-SSR220-DDA200-DDR220
AZ0408	178	67	13,0	SPR350-SPR430-STR350-STR430-SSR350-SSR430-DDR350-DDR430
AZ0411	200	79	19,3	SPR560-SPR670-STR560-STR670-SSR560-SSR670-DDR560-DDR670
AZ0413	250	105	40,0	SPR880-STR880-SSR880-DDR880
AZ0415	325	175	113,0	SPR1100-STR1100-SSR1100-DDR1100

**HOLLOW SADDLES**

Standard Plain					Cylinder Model	Optional Threaded				
Model	C	L	M	N		Model	C	L	M	N
LARZEP	mm	mm		mm		LARZEP	mm	mm		mm
AZ0531	19,5	34	M28x1,5	7	SH012	AZ0551	3/4"-16	34	M28x1,5	7
AZ0532	27,0	48	1 9/16"-16	8	SH022-SAH022	AZ0552	1"-8	48	1 9/16"-16	8
AZ0533	33,4	55	1 13/16"-16	9	SH030-SAH030-DH030-DAH030	AZ0553	1 1/4"-7	55	1 13/16"-16	9
AZ0536	56,0	80	2 3/4"-16	12	SH060-SAH060-DH060-DAH060	AZ0556	1 5/8"-5 1/2	80	2 3/4"-16	12
AZ0540	81,0	116	4"-16	13	SH100-SAH100-DH100-DAH100	AZ0560	2 1/2"-8	116	4"-16	13
AZ0545	81,0	135	4 1/4"-16	20	DH150-DAH150	AZ0565	2 1/2"-8	135	4 1/4"-16	20

**FITTINGS AND MANIFOLDS**



✔ Wide range of Fittings and Manifolds for multiple applications.

**HEXAGON NIPPLE**



Model	A	B	C	D
LARZEP			mm	mm
AZ1102	3/8"-NPT	3/8"-NPT	45	19
AZ1103	3/8"-NPT	3/8"-NPT	66	19
AZ1104	3/8"-NPT	3/8"-NPT	100	22

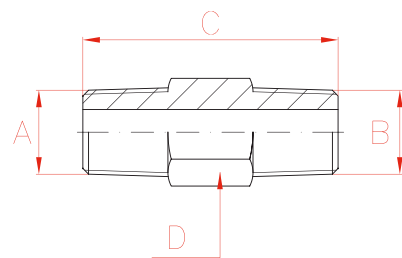

**ADAPTOR**



Model	A	B	C	D
LARZEP			mm	mm
AZ1112	3/8"-BSP	3/8"-NPT	36	27
AZ1113	3/8"-NPT	1/4"-BSP	36	27
AZ1114	3/8"-NPT	3/8"-BSP	36	27

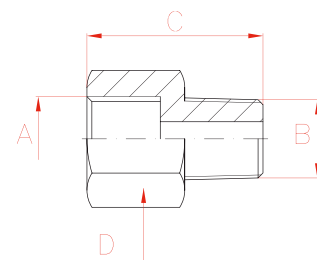

**COUPLING**



Model	A	B	C	D
LARZEP			mm	mm
AZ1142	3/8"-NPT	3/8"-BSP	45	27
AZ1143	3/8"-NPT	3/8"-NPT	45	27

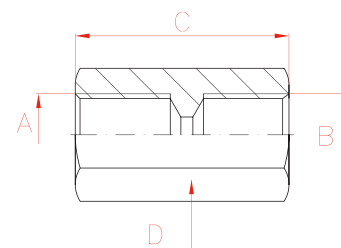



Type **AZ1**

Capacity -

Max. pressure **700 bar**



On request, LARZEP can supply other accessories to special requirements of threads and sizes.

**PLUG**



Model	A	C	D
LARZEP		mm	mm
AZ1182	3/8"-NPT	24	18
AZ1183	1/2"-NPT	28	22

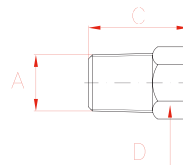

**ADAPTOR ELBOW**



Model	A	B	C	D
LARZEP			mm	mm
AZ1511	3/8"-NPT	3/8"-BSP	51	30
AZ1512	3/8"-NPT	3/8"-NPT	51	30

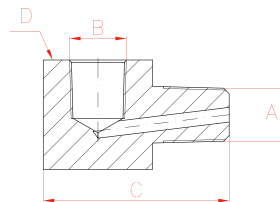

**ELBOW**



Model	A	B	C	D
LARZEP		mm	mm	mm
AZ1202	3/8"-NPT	40	25	12,5

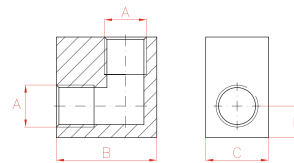

**TEE**



Model	A	B	C	D
LARZEP		mm	mm	mm
AZ1242	3/8"-NPT	40	25	12,5

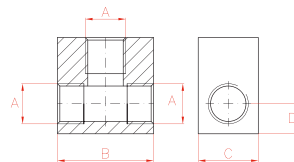

**CROSS**



Model	A	B	C	D
LARZEP		mm	mm	mm
AZ1282	3/8"-NPT	50	25	24

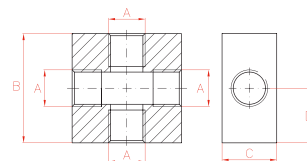

**GAUGE ADAPTOR**



Model	A	B	C	D
LARZEP			mm	mm
AZ1501	3/8"-NPT	3/8"-BSP	117	35
AZ1502	3/8"-NPT	1/4"-NPT	98	35
AZ1507	3/8"-NPT	1/4"-BSP	98	35

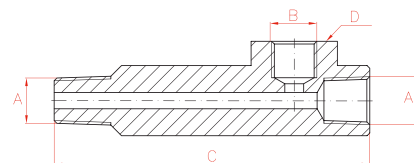

**MANIFOLDS**



Model	A	B	C	D	Ports
LARZEP			mm	°	No.
AZ1602	3/8"-NPT	3/8"-BSP	62	90°	2
AZ1604	3/8"-NPT	3/8"-BSP	82	60°	4
AZ1606	3/8"-NPT	3/8"-BSP	102	48°	6

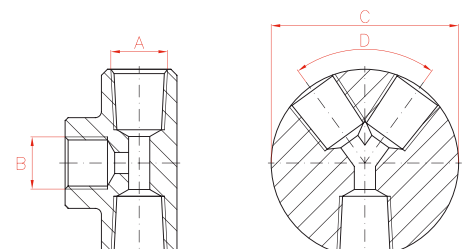



## DIRECTIONAL CONTROL VALVES



Type

**AZ8 - AZ9**

Capacity

4 - 30 l/min

Max. pressure

700 bar

## DIRECTIONAL CONTROL VALVES



- ✓ 3- or 4- ways directional control valves for single and double acting cylinders.
- ✓ Manually operated, without spring to centre.
- ✓ Suitable for remote operation.
- ✓ Possibility to select open or closed centre.

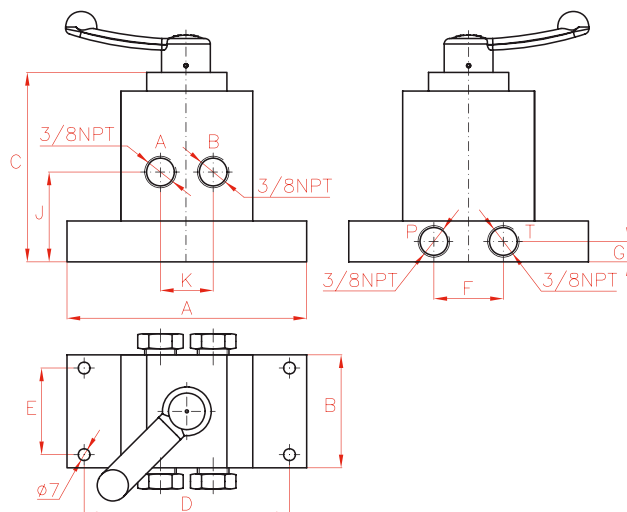

Symbol	Flow l/min	Model LARZEP	Operation Remote	Central Position	A mm	B mm	C mm	D mm	E mm	F mm	G mm	J mm	K mm
	4	<b>AZ8300</b>	Single act.	Open Centre	128	50	107	113	36,0	86	20	60	-
	30	<b>AZ9300</b>	Single act.	Open Centre	128	70	127	113	50,8	54	25	63	-
	4	<b>AZ8301</b>	Single act.	Closed Centre	128	50	107	113	36,0	86	20	60	-
	30	<b>AZ9301</b>	Single act.	Closed Centre	128	70	127	113	50,8	54	25	63	-
	4	<b>AZ8500</b>	Double act.	Open Centre	128	50	107	113	36,0	86	20	60	30
	30	<b>AZ9500</b>	Double act.	Open Centre	128	70	127	113	50,8	54	25	63	38
	4	<b>AZ8501</b>	Double act.	Closed Centre	128	50	107	113	36,0	86	20	60	30
	30	<b>AZ9501</b>	Double act.	Closed Centre	128	70	127	113	50,8	54	25	63	38



**PRESSURE GAUGES**

**PRESSURE GAUGES**



Type **AV-AVD-AT-AY**

Capacity **5 - 250 Tn**

Max. pressure **0 - 1.000 bar**

- ✓ High accuracy gauges,  $\pm 1.6\%$  full scale.
- ✓ Essential for monitoring working pressure or force.
- ✓ Glycerine filled gauges.
- ✓ Available as system pressure gauges or as dual scale gauges to measure load on specific cylinders.

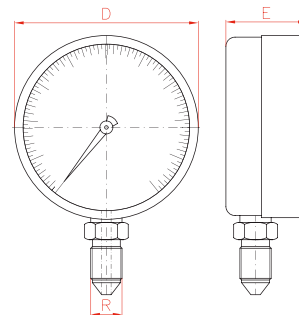

**WARNING**

Do not exceed the 70% of the nominal capacity of the gauge.



Digital pressure gauge: **AVD10008**  
Thread: 1/4"-BSP  
Gauge adaptor: **AZ1507**



Pressure gauge for Hollow Cylinders: **ATH**  
Digital Pressure Transducer: **AVT**

Used with	Model	Type		Scale	D	E	R	Gauge Adaptor
		Tn	kg/cm <sup>2</sup>					
All Cylinders	<b>AV10006</b>	-	1000	50	68	31	1/4"-NPT	AZ1502
	<b>AV10008</b>	-	1000	20	80	35	3/8"-BSP	AZ1501
	<b>AV10010</b>	-	1000	10	100	35	3/8"-BSP	AZ1501
Cylinders	<b>AT00410</b>	5 / 10	1000	-	100	35	3/8"-BSP	AZ1501
	<b>AT01610</b>	16 / 23	1000	-	100	35	3/8"-BSP	AZ1501
	<b>AT03010</b>	30 / 50	1000	-	100	35	3/8"-BSP	AZ1501
	<b>AT07510</b>	75 / 100	1000	-	100	35	3/8"-BSP	AZ1501
	<b>AT15010</b>	150 / 200	1000	-	100	35	3/8"-BSP	AZ1501
Press 10 Tn	<b>AY01008</b>	10	-	0,5	80	35	3/8"-BSP	AZ1501
Press 20 Tn	<b>AY02008</b>	20	-	0,5	80	35	3/8"-BSP	AZ1501
Press 30 Tn	<b>AY03008</b>	30	-	2	80	35	3/8"-BSP	AZ1501
Press 60 Tn	<b>AY06010</b>	60	-	2	100	35	3/8"-BSP	AZ1501
Press 120 Tn	<b>AY12010</b>	120	-	4	100	35	3/8"-BSP	AZ1501
Press 250 Tn	<b>AY25010</b>	250	-	5	100	35	3/8"-BSP	AZ1501

## HYDRAULIC TOOLS

**LARZEP** offers a wide range of tools for different applications: Chain cutters, Cable cutters, Nut Splitters, Pullers, Spread cylinders, Dynamometers and Load cells, Toe jacks, Lifting cushions, Square drive and Hexagon Torque wrenches, Punching heads and Crimping tools.

- ✓ Chain cutters designed for chain and high resistance bar cutting.  
Available with either built-in pump, or powered by a separate pump.
- ✓ Cable cutters for operation in any place and position, the cable cutters make heavy jobs easier in forced and uncomfortable positions or on difficult access places like poles, shafts or high-voltage towers.
- ✓ Nut Splitters designed to work either cutting or deforming nuts, depending on the material grade.
- ✓ Wide range of Pullers from 5 to 50 Tn to cover most pulling applications.  
Available in 2 and 3 Jaws puller,  
Cross Bearing puller, Bearing Cup puller, Bearing puller and Self-centering pullers.
- ✓ Spread cylinders are used for many tasks in confined access situations.
- ✓ Dynamometers from 5 to 100 Tn, are used to measure tension.  
Load Cells from 5 to 150 Tn, measure compression loads.  
Used in pile testing applications.
- ✓ Toe jacks are compact and lightweight for easy transportation.  
Are used for lifting load in reduced height access situations.
- ✓ Pneumatic lifting cushions made of friction resistant material.  
Often used in rescue operations, rubble lifting in collapses and other lifting applications with very limited access.
- ✓ Flange spreaders used for safely pipe flange opening.



# TOOLS

- ✓ Torque wrenches are designed to tighten and loosen nuts requiring accurate high torque during bolt tightening and maximum torque during bolt loosening.
- ✓ Lightweight, easy transportable punching heads are designed for round, square or oblong puncher holes in mild steel sheets.
- ✓ Compression crimping tools for low, medium and high voltage terminals and sleeves.

Models	Tool type	Capacity		Page
		Tn (kN)		
CK	Hydraulic Chain Cutters	13-112 (135-1.120)		126
CC	Hydraulic Cable Cutters	5-43 (50-437)		128
CN	Hydraulic Nut Splitters	13-113 (135-1.134)		130
FU - FV - FZ	Hydraulic Pullers	5-50		132
FA	Self-Centering Pullers	10-50		135
CY	Spread Cylinders	0.8-15 (8-150)		136
CT - C	Dynamometers & Load Cells	5-150 (44-1.449)		138
AA	Lifting Cushions	6-65		140
AU	Hydraulic Toe Jacks	20-60		141
BS	Flange Spreaders	5-10		142
LS	Square Drive Hydraulic Torque Wrenches	1.898-34.079 Nm		144
LX	Low Profile Hydraulic Hexagon Torque Wrenches	2.712-47.450 Nm		148
PH	Portable Hydraulic Punching Heads	15-45		152
CB - CH - CM	Hydraulic Crimping Tools	5-100		153

**HYDRAULIC CHAIN CUTTERS**



- ✓ Maximum working pressure 700 bar.
- ✓ CK0016 model includes an integral built-in hand pump.  
Other models are powered by an external hand, air, electric, or petrol pump.
- ✓ CK0216, CK0230 and CK0250 models are double acting, for fast retraction.
- ✓ CK0116 and CK0216 are not equipped with handle.
- ✓ All models are provided with a male ball quick coupler AZ3321.
- ✓ Available battery powered portable pump HAB1102.

**HAB1102**  
Battery Powered Portable Hydraulic Pump



P.101

**Z12107**  
Air Hydraulic Pump



P.86

**HBM**  
Manual Powerpack



P.88





CK0016

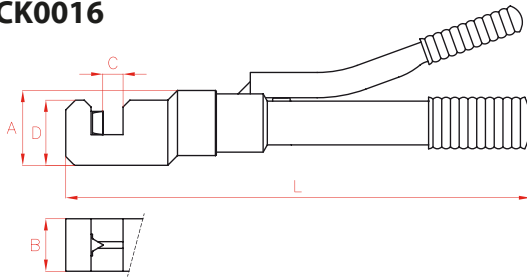

CK0116 - CK0130

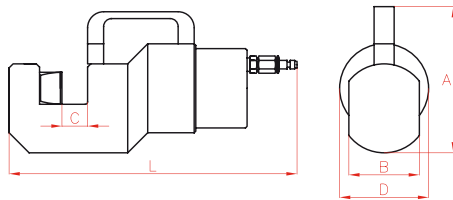

CK0216 - CK0230 - CK0250

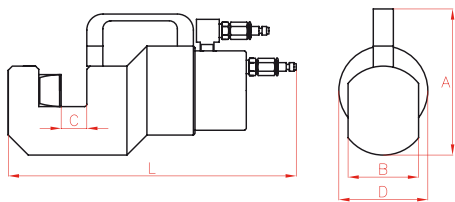

Type	<b>CK</b>
Capacity	<b>13 - 112 Tn</b>
Chain	<b>max. 50 mm</b>
Max. pressure	<b>700 bar</b>

Model	Replacement Blades	
	Mobile	Fixed
CK0016	CRK16/1	CRK16/2
CK0116	CRK16/1	CRK16/2
CK0130	CRK30/1	CRK30/2
CK0216	CRK16/1	CRK16/2
CK0230	CRK30/1	CRK30/2
CK0250	CRK50/1	CRK50/2

\* maximum ø

Model	Capacity	Oil Cap.	Weight	A	B	C	D	L	Chain*	Strength	Bar*	Strength
LARZEP	kN	cm <sup>3</sup>	kg	mm	mm	mm	mm	mm	mm	by grades	mm	N/mm <sup>2</sup>
CK0016	135	-	5,8	81,5	54	20	68	489	19	28 - 43	19	700
									14	60 - 80	15	1.000
CK0116	135	38	4,8	81,5	54	19,5	68	290	19	28 - 43	19	700
									14	60 - 80	13	1.400
											11	1.600
CK0130	390	182	16,8	183	88	31,5	113	360	30	28 - 43	30	700
									20	60 - 80	25	1.000
CK0216	135	38	8,4	126	54	19,5	81	343	30	28 - 43	20	1.400
									19	28 - 43	17	1.600
											14	60 - 80
CK0230	345	161	16,0	183	88	30	113	412	30	28 - 43	11	1.600
									20	60 - 80	25	1.000
											17	1.600
CK0250	1.120	842	68,0	228	120	52	207	475	50	28 - 43	30	700
									40	60 - 80	45	1.000
											40	1.400
											35	1.600



## HYDRAULIC CABLE CUTTERS



- ✓ CC0260 model is double acting and is especially recommended for sub-sea applications. Optionally we can supply special seal kits for deep water operation.
- ✓ CC0018, CC0040 and CC0075 models are self contained, with integral built-in pump. These tools are supplied with a relief valve to prevent overload.
- ✓ Single acting models have spring return.
- ✓ Rotating heads for easy operation.
- ✓ Installing replacement blades is a simple operation.
- ✓ All models are provided with a male ball quick coupler AZ3321.
- ✓ CC0190 and CC01120 are equipped with handle.
- ✓ Carry box included for easy transport and tool protection.

**HAB1102**

Battery Powered Portable Hydraulic Pump



P.101

**Z12107**

Air Hydraulic Pump



P.86

**HYDRAULIC CABLE CUTTERS**



Type

**CC**

Capacity

**5 - 43 Tn**

Cable

**max. 120 mm**

Max. pressure

**700 bar**

**CC0118 - CC0140 - CC0160 - CC0175 - CC0190 - CC01120**

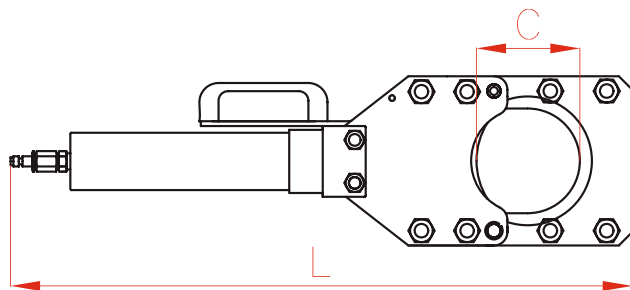

**CC0018 - CC0040 - CC0075**

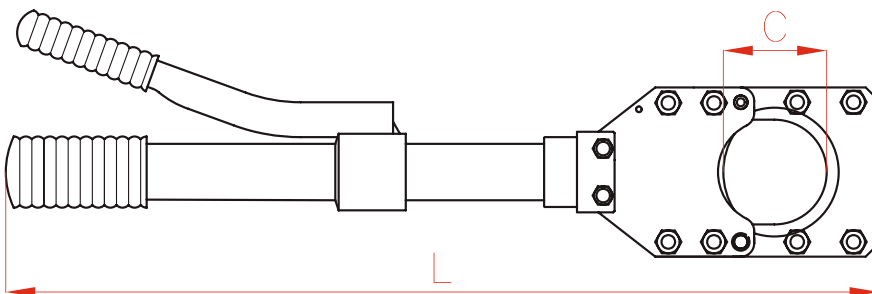

Model	Replacement Blades
LARZEP	LARZEP
CC0018	CRC18
CC0040	CRC35-40
CC0075	CRC75
CC0118	CRC18
CC0140	CRC35-40
CC0160	CRC0160
CC0175	CRC75
CC0190	CRC0190
CC01120	CRC01120
CC0260	CRC0160

Model	Capacity	Oil Capacity	L	C	Weight	Wire Rope ø (Al)	Cable ø			Wire Rope ø (Steel) <sup>1)</sup>	
							Telephone	Lead Shielded	Underground	Cable	Wire
	kN	cm <sup>3</sup>	mm	mm	kg	mm	mm	mm	mm	mm	mm
CC0018	70	-	385	19	2,8	18	18	18	18	18	1
CC0040	135	-	490	41	5,6	40	40	40	40	32	1
CC0075	70	-	650	77	6,6	40	75	75	75	*	*
CC0118	70	24	212	18	2,0	18	18	18	18	18	1
CC0140	135	86	292	40	5,3	40	40	40	40	32	1
CC0160	437	420	388	64	15,8	60	60	60	60	60	2
CC0175	70	74	451	75	5,5	40	75	75	75	*	*
CC0190	109	149	535	90	10,0	35	90	90	90	*	*
CC01120	109	203	635	120	11,7	35	120	120	120	*	*
CC0260	390	431	480	64	24,6	60	60	60	60	60	2

\* This unit is not designed to cut this material. Any attempt to do so may result in personal injury or damage to the unit and will void the warranty.

Shown diameters are only for guidance.

1) Max. Strength 1.800 N/mm<sup>2</sup>

## HYDRAULIC NUT SPLITTERS



- ✓ Designed to work in two different ways, depending on the material grade of the nuts, either cutting or deforming them, allowing nut removal.
- ✓ CN0024 Model with integral pump, provides more confort.
- ✓ CN0224 Model especially designed to cut guard rail nuts.
- ✓ CN0324 Model, with open design, especially suitable for limited access situations.
- ✓ Plastic carry box included for easy transport and tool protection.
- ✓ Relief valve on CN0024 to avoid overloading.
- ✓ All models are provided with a male ball quick coupler AZ3321.

Model	Capacity	Volume	Length	Weight	Quality			Minimun	Replacement Blade
					12.9	8.8	5.6		
LARZEP	kN	cm <sup>3</sup>	mm	kg				ASTM A 194	LARZEP
CN0024	135	-	471	4,8	M24 7/8"	M27 1"	M27 1"	M12 1/2"	CRN24
CN0152	437	296	368	14,0	M52 2"	M52 2"	M52 2"	M27 1"	CRN33-52
CN0180	1.134	479	435	40,0	M80 3"	M80 3"	M80 3"	M68 2-1/2"	CRN0180
CN0224	135	47	207	3,7	M24 7/8"	M24 7/8"	M24 7/8"	M10 3/8"	CRN0224
CN0233	345	156	270	12,2	M33 2"	M36 1-1/4"	M36 1-1/4"	M24 7/8"	CRN0233
CN0324	135	49	296	5,0	-	M24 7/8"	M24 7/8"	M10 3/8"	CRN0324



**HAB1102**

Battery Powered Portable Hydraulic Pump



P.101

**Z12107**

Air Hydraulic Pump



P.86

**HYDRAULIC NUT SPLITTERS**



Type

**CN**

Capacity

**13 - 113 Tn**

Nut

**M10 - M80 mm**

Max. pressure

**700 bar**



**WARNING**

The tool cuts materials with a resistance lower than 500 N/mm<sup>2</sup> and deforms all materials up to a resistance of 1.250 N/mm<sup>2</sup>.

**CN0024**

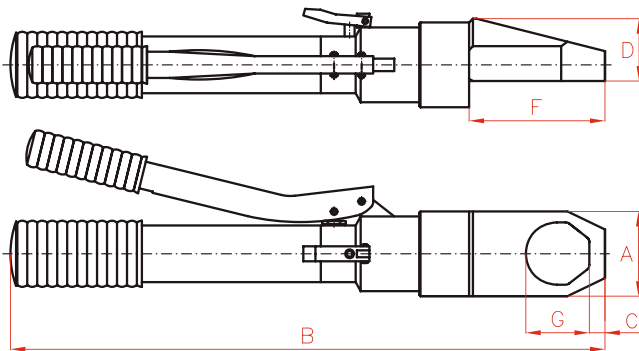

**CN0224-CN0233**

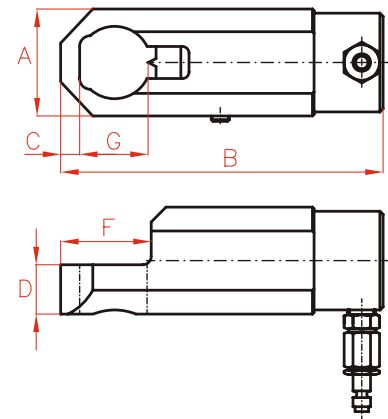

**CN0324**

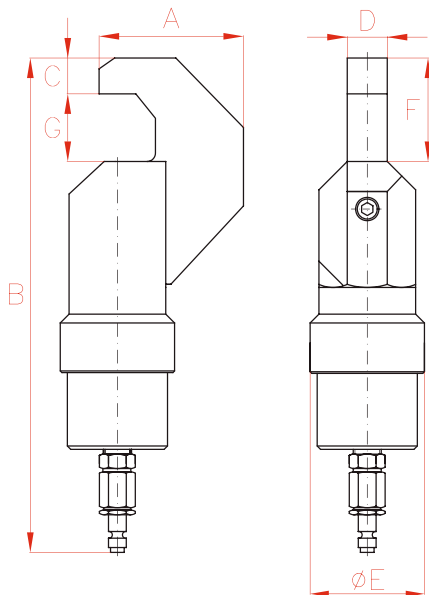

**CN0152-CN0180**

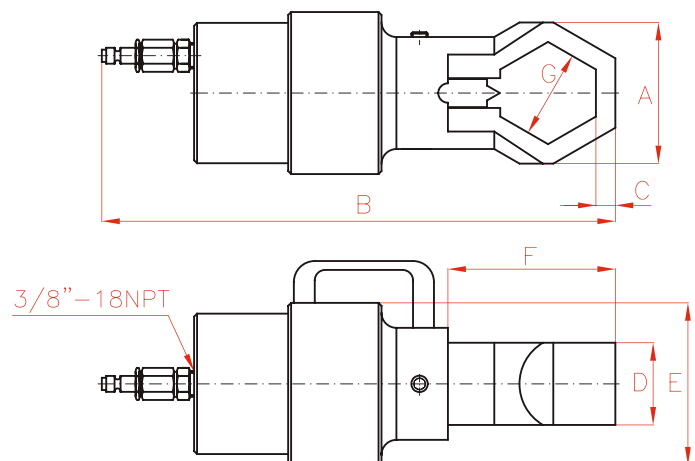

Model	A	B	C	D	E	F	G
LARZEP	mm	mm	mm	mm	mm	mm	mm
CN0024	68	471	12,5	51	-	108	48
CN0152	131	368	27	55	120	136	83
CN0180	185	435	37	90	200	202	120
CN0224	65	207	12	30	-	56	40
CN0233	106	270	24	55	-	84	59
CN0324	87	296	22	24	69	62	38

Model	Nut	Across Flats
LARZEP	ASTM A 194	mm
CN0024	M12 - M27	19 - 41
CN0152	M27 - M52	41 - 80
CN0180	M68 - M80	100 - 115
CN0224	M10 - M24	17 - 36
CN0233	M24 - M36	36 - 55
CN0324	M10 - M24	17 - 36

**HYDRAULIC PULLERS**



- ✓ Wide range of models from 5 to 50 Tn suitable for most maintenance pulling applications.
- ✓ All pullers are delivered in a strong wooden box for ease of transport and storage.
- ✓ Manufactured in high quality forged steel, includes hydraulic and all mechanical components.
- ✓ Hydraulic part includes: cylinder, pump, hose, pressure gauge, gauge adaptor, male coupling and hollow saddle.
- ✓ Mechanic part includes:
  - 2 Jaws puller (FX) / 3 Jaws puller (FV)
  - Complete Cross Bearing puller (FZ) that includes:
    - Simple Cross Bearing puller (FT) with long and short extension pieces,
    - Bearing Cup puller (FI), Bearing puller (FR)
- ✓ Universal puller (FU), Jaws pullers (FX and FV) and Cross Bearing puller (FT), include hydraulic and mechanical parts.

**FX - FV Jaws puller**

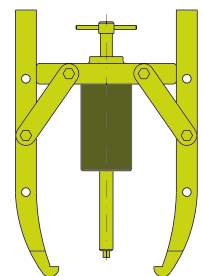

**FZ Cross Bearing pullers**

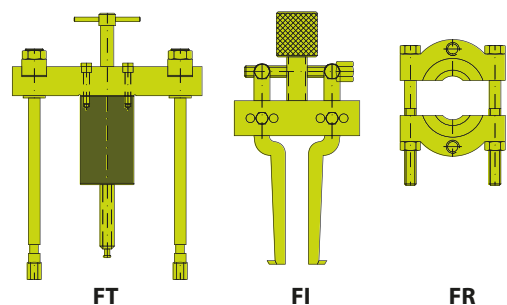



**UNIVERSAL HYDRAULIC PULLERS - FU** (Include hydraulic and mechanic part)

Capacity (Tn)	5	10	20	30	50
Model	FU0500	FU1000	FU2000	FU3000	FU5000
Hydraulic Part	JH00518/1	JH01204/1	JH02205/1	JH03005/1	JH06008/1
Mechanic Part	FU0500/M	FU1000/M	FU2000/M	FU3000/M	FU5000/M
Weight (kg)	20	35	80	145	315



Type **FU - FV - FZ**

Capacity **5 - 50 Tn**

Max. pressure **700 bar**

**HYDRAULIC PART**

Capacity (Tn)	5	10	20	30	50
Model	JH00518/1	JH01204/1	JH02205/1	JH03005/1	JH06008/1
Cylinder	SM00518	SH01204	SH02205	SH03006	SH06008
Pump	W00307	W00307	W10707	W20707	W21207
Hose	AP2015	AP2015	AP2015	AP2015	AP2020
Gauge adaptor	AZ1502	AZ1502	AZ1502	AZ1502	AZ1502
Pressure gauge	AV10006	AV10006	AV10006	AV10006	AV10006
Male half coupling	AZ3120	AZ3120	AZ3120	AZ3120	AZ3120
Hollow saddle	-	AZ0551	AZ0552	AZ0553	AZ0556
Weight (kg)	7	8	16	21	34



**MECHANIC PART**

Capacity (Tn)	5	10	20	30	50	FV	FX	FZ	FT
Model	FU0500/M	FU1000/M	FU2000/M	FU3000/M	FU5000/M				
Jaw	FU0507	FU1007	FU2007	FU3007	FU5007	3	2	-	-
3 Jaws crosshead	-	-	FU2008	FU3008	FU5008	✓	-	-	-
2 Jaws crosshead	-	-	FU2009	FU3009	FU5009	✓	✓	-	-
2 and 3 Jaws crosshead	FU0508	FU1008	-	-	-	✓	✓	-	-
Arms	FU0510	FU1010	FU2010	FU3010	FU5010	6	4	-	-
Jaws bolts + Nuts	FU0511	FU1011	FU2011	FU3011	FU5011	6	4	-	-
Slinde + Handle	-	FU1012	FU2012	FU3012	FU5012	✓	✓	✓	✓
Short bolts (2)	-	14A0330	14A0074	14A0075	14A0076	✓	✓	-	-
Bearing puller	FR1000	FR1000	FR2000	FR3000	FR5000	-	-	✓	-
Gross crosshead	FU0517	FU1017	FU2017	FU3017	FU5017	-	-	✓	✓
Blank nuts (2)	FU1018	FU1018	FU2018	FU3018	FU5018	-	-	✓	✓
Washer (2)	FU1019	FU1019	FU2019	FU3019	FU5019	-	-	✓	✓
Slides (2)	FU0520	FU1020	FU2020	FU3020	FU5020	-	-	✓	✓
Fixing nuts (2)	FU0521	FU2021	FU2021	FU3021	FU5021	-	-	✓	✓
Large extenders (2)	FU0522	FU1022	FU2022	FU3022	FU5022	-	-	✓	✓
Short extenders (2)	FU0523	FU1023	FU2023	FU3023	FU5023	-	-	✓	✓
Bearing cup puller	-	FI1000	FI2000	FI3000	FI5000	-	-	✓	-
Point protector	FU0525	FU1025	FU2025	FU5025	FU5025	✓	✓	✓	✓
Connection nuts (2)	14B0050	14B0051	14B0029	14B0030	14B0031	-	-	✓	✓
Long bolts (2)	-	14A0331	14A0098	14A0099	14A0100	-	-	✓	✓
Weight (kg)	11	27	63	123	280				

✓ Included - Not available



### JAWS PULLER FX - FV

(Include hydraulic and mechanic part)

Capacity	2 JAWS				3 JAWS			
	Model	A max.	B max.	Weight	Model	A max.	B max.	Weight
Tn	LARZEP	mm	mm	kg	LARZEP	mm	mm	kg
5	FV0500	240	225	7	FV0500	240	225	7
10	FV1000	350	320	9	FV1000	350	320	9
20	FX2000	480	340	18	FV2000	480	320	26
30	FX3000	580	390	30	FV3000	680	390	46
50	FX5000	920	727	66	FV5000	980	710	96

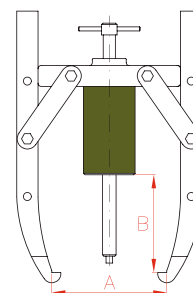

FX - FV

### FULL CROSS BEARING PULLER - FZ

(Include hydraulic and mechanic part: FZ = FT + FI + FR)

Capacity	Model	Simple Cross Bearing Puller	Bearing Cup Puller	Bearing Puller
Tn	LARZEP	FT	FI	FR
5	FZ0500	FT0500	-	FR1000
10	FZ1000	FT1000	FI1000	FR1000
20	FZ2000	FT2000	FI2000	FR2000
30	FZ3000	FT3000	FI3000	FR3000
50	FZ5000	FT5000	FI5000	FR5000

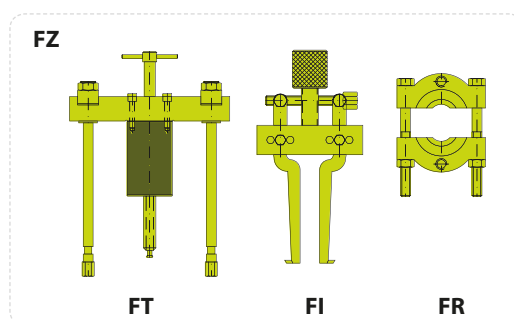

### SIMPLE CROSS BEARING PULLER - FT

(Include hydraulic and mechanic part)

Capacity	Model	A min.	A max.	B max.	Weight
Tn	LARZEP	mm	mm	mm	kg
5	FT0500	40	185	170	7
10	FT1000	115	260	300	8
20	FT2000	170	345	265	19
30	FT3000	185	425	284	37
50	FT5000	220	580	447	71

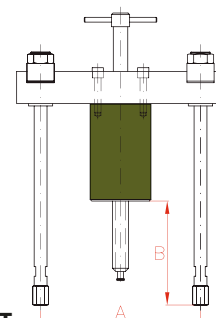

FT

### BEARING CUP PULLER - FI

(Only mechanic part)

Capacity	Model	A min.	A max.	B	Weight
Tn	LARZEP	mm	mm	mm	kg
10	FI1000	40	145	115	2,2
20	FI2000	40	145	115	2,4
30	FI3000	60	240	150	6,0
50	FI5000	60	240	150	6,4

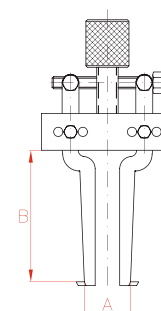

FI

### BEARING PULLER - FR

(Only mechanic part)

Capacity	Model	A min.	A max.	B	D
Tn	LARZEP	mm	mm	mm	UN
5 - 10	FR1000	10	110	130	5/8" UNF-18
20	FR2000	12	134	155	5/8" UNF-18
30	FR3000	17	250	260	1" UNF-14
50	FR5000	35	300	300	1 1/4" UNF-12

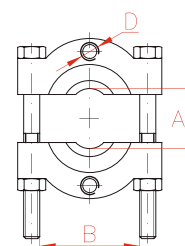

FR



SELF-CENTERING PULLERS

SELF-CENTERING PULLERS



Type	<b>FA</b>
Capacity	<b>10 - 50 Tn</b>
Max. pressure	<b>700 bar</b>

- ✓ Self-Centering Puller available in 10, 20, 30 and 50 Tn versions.
- ✓ Ergonomic, self-centering of the jaws provides easy and safe setups on pulling jobs.
- ✓ FA Self-Centering Pullers include the hydraulic components and mechanical components.
- ✓ The large jaw opening allows bigger diameter reach and spread which makes the puller more versatile.

Model	A	B max.	Weight
LARZEP	mm	mm	kg
<b>FA1000</b>	50-350	320	25
<b>FA2000</b>	70-480	340	49
<b>FA3000</b>	90-680	390	76
<b>FA5000</b>	120-1.080	750	177

Capacity (Tn)	10	20	30	50
Model	FA1000	FA2000	FA3000	FA5000
Hydraulic part*	JH01204/1	JH02205/1	JH03005/1	JH06008/1
Mechanic part	FA1000/M	FA2000/M	FA3000/M	FA5000/M

\*See page 127.

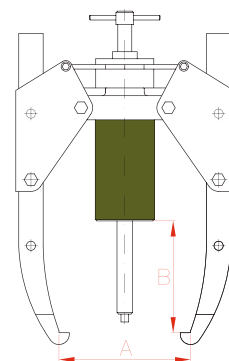

**WEDGE SPREADER**



**WEDGE SPREADER**

Type

**CY**

Capacity

**15 Tn**

Max. pressure

**700 bar**



- ✓ 15 Tn capacity wedge spreader.
- ✓ Lightweight and ergonomic tool. Easy and quick maintenance.
- ✓ Specially designed for pipe and flange repair and maintenance.  
Can be used also for seal replacement, removing elbows or heavy equipment maintenance.
- ✓ Required access gap of only 5 mm.
- ✓ Suitable for harsh offshore environment due to corrosion protection.
- ✓ Recommended to be used in pairs.
- ✓ Options: Aluminium Safety block CY15B; Handle CY15H; Kit CY1501S, with pump and 2 wedge spread

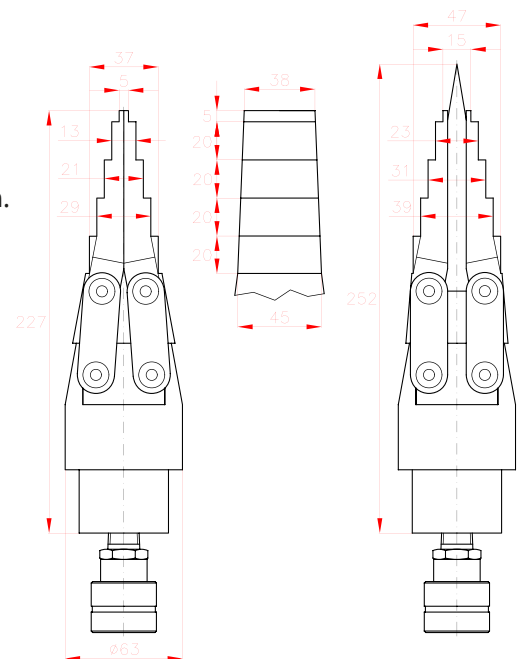

**Aluminium Safety Block CY15B as option.**

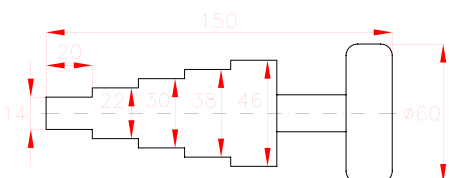

Capacity	Model	Oil Capacity	Access Gap	Max. open width	Weight
Tn	LARZEP	cm <sup>3</sup>	mm	mm	kg
15	CY1501	16	5	47	3,2



Always read the safety instructions.

SPREAD CYLINDERS



Type	<b>CY</b>
Capacity	<b>0,8 - 1 Tn</b>
Max. pressure	<b>700 bar</b>



- ✓ CY series spreaders are used for many tasks in confined access situations.
- ✓ CY0109G is used for very confined situations and CY0122 is used for greater spreading distance.
- ✓ CY0109G and CY0122 models are supplied with AZ3140 high flow female couplers.
- ✓ Also available CY0109 and CY0122P fitted with AZ3240 low flow female coupler.

**CY0109G**

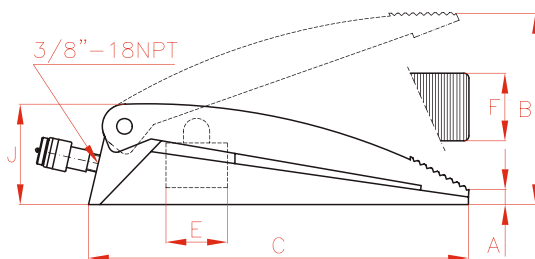

**CY0122**

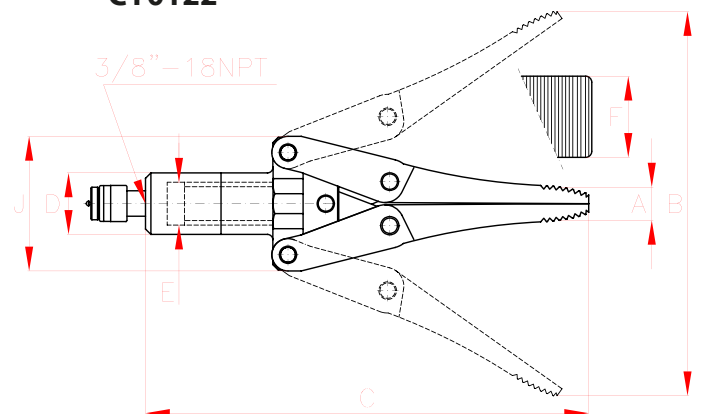

Capacity		Stroke	Model	Oil Cap.	Area	A	B	C	D	E	F	J	Weight
Tn	kN	mm	LARZEP	cm <sup>3</sup>	cm <sup>2</sup>	mm	mm	mm	mm	mm	mm	mm	kg
1	10	75	<b>CY0109G</b>	10	7	15	90	168	-	29	55	55	2
0,8	8	189	<b>CY0122</b>	63	11,3	31	220	382	50	38	50	124	6

## DYNAMOMETERS & LOAD CELLS



- ✓ Accuracy  $\pm 4\%$  full scale.
- ✓ 5 to 100 Tn models available for dynamometers, and 5 to 150 Tn models for load cells.
- ✓ Includes glycerine filled gauges with maximum load indicating pointer.

### CT DYNAMOMETERS

- ✓ Measure loads in compression.
- ✓ Can be used for measuring tension loads in cables, tensile testing and can be used as a weighing device.

### C LOAD CONTROL CELLS

- ✓ Portable compression load cells, measure loads in compression.
- ✓ All models have remote mounted gauge with 0,8 metre hose AP2008.



Type	<b>CT - C</b>
Capacity	<b>5 - 150 Tn</b>
Max. pressure	<b>700 bar</b>

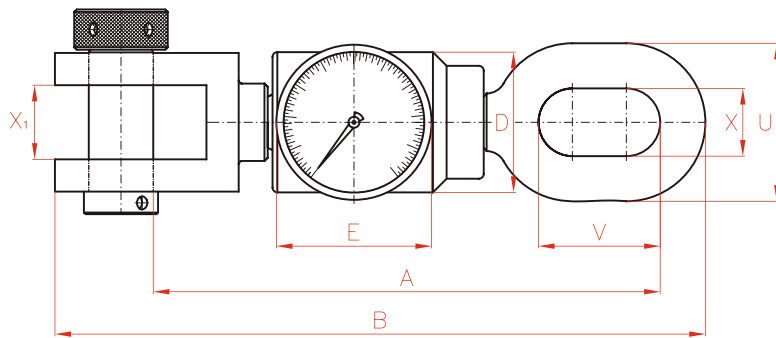

**DYNAMOMETERS**

Capacity		Model	A	B	D	E	U	V	X	X1	Weight	Gauge	
Tn	kN	LARZEP	mm	mm	mm	mm	mm	mm	mm	mm	kg	Model	Scale (Tn)
5	49	CT00525	328	397	87	100	98	98	42	46	12,5	AX00510	0,05
10	98	CT01025	367	446	102	100	107	108	46	50	18,5	AX01010	0,1
30	303	CT03025	447	563	125	100	108	153	50	70	27,0	AX03010	0,3
50	486	CT05025	643	793	148	100	130	150	50	50	50,0	AX05010	0,5
100	1.026	CT10025	726	851	260	100	296	146	146	146	120,0	AX10010	1

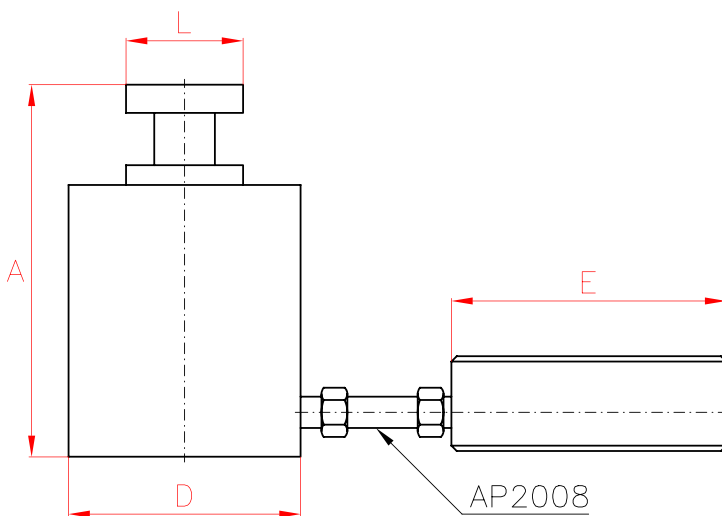

Pressure gauge separated from the load cell with a 0,8 metre hose AP2008.



DDR200015 cylinder. 2.000 Tn capacity cylinder for electronic load cell for pile testing.

**LOAD CELLS**

Capacity		Model	A	D	E	L	Weight	Gauge	
Tn	kN	LARZEP	mm	mm	mm	mm	kg	Model	Scale (Tn)
5	44	CX00510	39	60	100	25	1,9	AX00510	0,05
10	99	CX01010	54	83	100	38	2,3	AX01010	0,1
30	287	C03010	72	114	100	60	4,8	AX03010	0,3
50	486	C05010	84	140	100	61	7,3	AX05010	0,5
100	953	C10010	103	178	100	88	15,7	AX10010	1
150	1.449	C15010	116	216	100	111	25,7	AX15010	1,5



Larzep designs and manufactures special cylinders for electronic load cells for pile testing. For further information, please contact our Internal Sales department.



**LIFTING CUSHIONS**



Type **AA**

Capacity **6 - 65 Tn**

Max. pressure **8 bar**

**LIFTING CUSHIONS**



- ✓ Used in rescue operations, rubble lifting in collapses and other lifting applications with very limited access. Excellent for lifting loads at restricted spaces.
- ✓ Pneumatic cushion made of friction resistant material.
- ✓ Closed height of 28 mm.
- ✓ Working pressure: 8 bar.
- ✓ 1/4" BSP male thread.
- ✓ Use two cushions to increase the lifting height.
- ✓ Hoses, couplers and control valves are available.

\* Maximum capacity when using the maximum effective lifting area.  
Lifting capacity decreases as the load is being lifted.

Model	Max. Capacity*	Stroke	Volume	Dimensions	Weight
LARZEP	Tn	mm	l	mm	kg
AA00617	6	175	4,5	300x300x28	2,5
AA01423	14	235	11,7	420x420x28	6
AA01928	19	280	23,4	510x510x28	8
AA03034	30	345	41,4	620x620x28	12
AA04341	43	410	72,0	750x750x28	17
AA06550	65	500	139,5	920x920x28	23

Model	Hose	
LARZEP	m	
AZN2020	2	
AZN2040	4	
AZN2100	10	
Model	Valve	Weight
LARZEP	Outlet No.	kg
AZN6100	1	1,1
AZN6501	2	2,2
Model	Coupler	
LARZEP	1/4" BSP	
AZN3021	Male	
AZN3041	Female	



HYDRAULIC TOE JACK

HYDRAULIC TOE JACK



Type **AU**

Capacity **20 - 60 Tn**

Max. pressure **700 bar**



- ✓ Compact and lightweight jacks for easy transportation.
- ✓ Load can be lifted with either toe or main plunger.
- ✓ Fitted with relief valve to prevent overloading.
- ✓ Excellent for lifting loads in limited access situations.
- ✓ Pumping handle included.

Capacity	Model	Toe Capacity	Stroke	Length	Width	Toe Height	Closed Height	Weight
Tn	LARZEP	Tn	mm	mm	mm	mm	mm	kg
20	AU02015	8	152	246	121	67	280	15
	AU02030	8	305	246	121	67	456	23
30	AU03015	12	152	273	140	73	281	21
	AU03030	12	305	273	140	73	472	32
60	AU06015	24	152	342	190	73	327	44
	AU06030	24	305	342	190	73	540	65

**FLANGE SPREADER**



**FLANGE SPREADER**



Type **BS**

Capacity **5 - 10 Tn**

Max. pressure **700 bar**

- ✓ 5 and 10 Tn models available.
- ✓ Used for safely opening pipe flanges.
- ✓ Adjustable jaw width from 70 to 226 mm.
- ✓ Ergonomic and lightweight tools.
- ✓ Can be operated individually or in pairs when the diameter of the flange is too big.

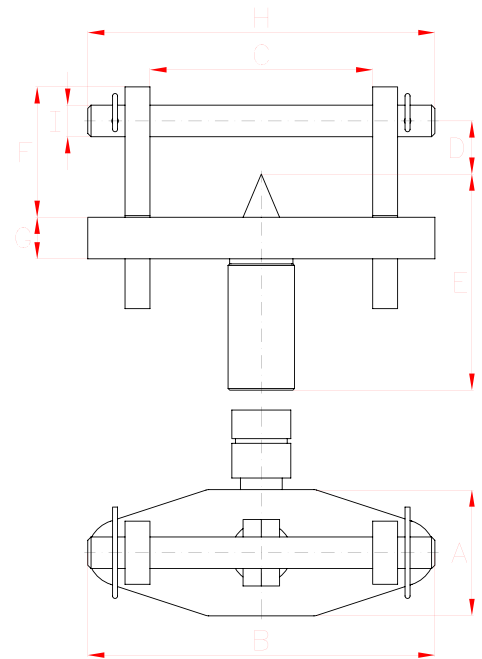

Capacity	Stroke	Module	Oil. Cap	Max. Flange thickness	A	B	C (mm)		D	E	F	G	H	I	Weight
Tn	mm	LARZEP	cm <sup>3</sup>	mm	mm	mm	min	max	mm	mm	mm	mm	mm	mm	kg
5	25	<b>BS00502</b>	18	2 x 57	76	209	70	155	32	130	79	25	209	19	4,2
10	55	<b>BS01005</b>	78	2 x 92	126	300	110	226	57	148	115	38	291	30	13,5



HYDRAULIC TORQUE WRENCHES



Type	<b>LS - LX</b>
Torque	<b>198 - 47.450 Nm</b>
Max. pressure	<b>690 bar</b>

- ✓ Square drive and low profile hexagon torque wrenches.
- ✓ Robust design to tighten and loosen nuts.
- ✓ Torque accuracy:  $\pm 3\%$  across full stroke.
- ✓ Wide range of accessories available.
- ✓ Torque wrench pumps HAT available.

 Always read the safety instructions.

Choose the most suitable model for the application from the wide range available and ensure that it will **not exceed 80%** of its nominal capacity during normal operation.

Remember that when loosening bolts or nuts a torque value higher than tightening torque is required. Depending on conditions, the loosening torque can reach 2,5 x the tightening torque.



**HAT**  
Torque Wrench Pump.



P.103

**AZ3**  
Coupler included.



P.108

**SQUARE DRIVE HYDRAULIC TORQUE WRENCHES**



- ✓ Designed to tighten and loosen nuts requiring accurate high torque during bolt tightening and maximum torque during bolt loosening.
- ✓ Compact body construction, provides high strength and small operating radius.
- ✓ 35° rotation angle and rapid return stroke.
- ✓ Adjustable 360° reaction arm with quick release lever.
- ✓ Easy positioning that provides the maximum torque at any angle.
- ✓ Torque accuracy: ±3% across full stroke.
- ✓ All models include LSQ square drive, with push button release for quickly reversing for tightening and loosening applications.

Torque (Nm)		Model	Square Drive	A	B	C	D	E	F	G	H	Weight
Min.	Max.	LARZEP	"	mm	mm	mm	mm	mm	mm	mm	mm	kg
198	1.898	LS02	3/4"	39	65	108	97	136	25	70	129	2,7
433	4.339	LS04	1"	48	78	135	128	173	33	90	161	5,0
835	8.144	LS08	1 1/2"	55	92	169	157	192	40	110	188	8,5
1.491	14.914	LS15	1 1/2"	72	114	197	190	228	50	133	229	15,0
3.407	34.079	LS34	2 1/2"	89	143	246	244	287	64	182	295	31,0



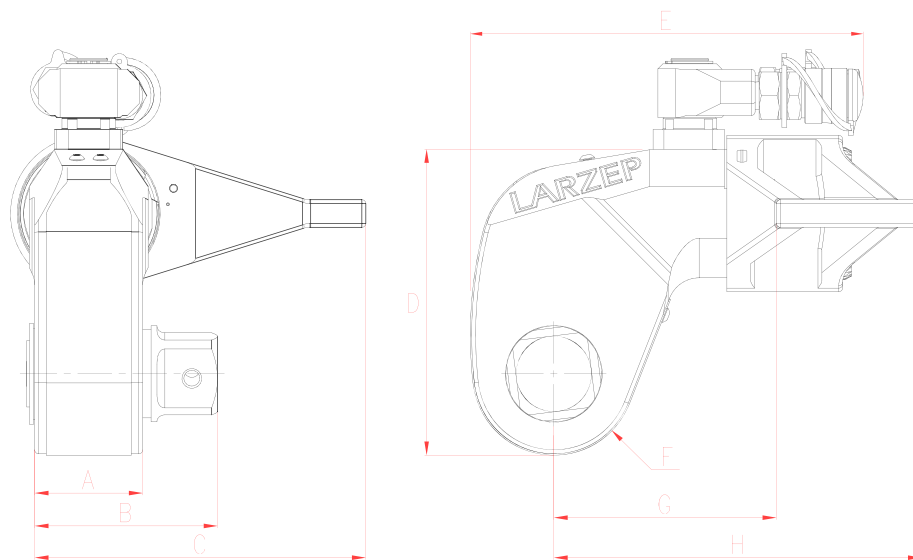

Type	<b>LS</b>
Torque	<b>198 - 34.079 Nm</b>
Max. pressure	<b>690 bar</b>



Available wide range of heavy-duty impact sockets.  
Wide range of accessories available: Reaction Tube Extensions and Extended Reaction Arms.  
Optional Allen hexagonal Drives and Short Reaction Arms for use with allen drives.  
Several models of HAT torque wrench pumps available.

### Extended Reaction Arms

Wrench	Max. Torque	Model	A	B	C	D	E	Weight
Model	Nm	LARZEP	mm	mm	mm	mm	mm	kg
LS02	1.800	LS02LA1	94	86	127	24	34	0,8
	1.640	LS02LA2	119	97	138	24	34	1,0
	1.530	LS02LA3	145	109	148	24	34	1,2
LS04	3.915	LS04LA1	111	106	168	34	48	1,6
	3.710	LS04LA2	137	117	182	34	48	2,0
	3.570	LS04LA3	162	132	198	34	48	2,5
LS08	7.840	LS08LA1	138	128	192	39	62	2,3
	7.450	LS08LA2	163	144	207	39	62	2,7
	7.175	LS08LA3	189	159	222	39	62	3,4
LS15	14.650	LS15LA1	149	157	232	46	76	4,4
	13.955	LS15LA2	175	172	247	46	76	5,1
	13.390	LS15LA3	200	187	261	46	76	5,8
LS34	33.535	LS34LA1	183	209	295	50	100	7,6
	32.045	LS34LA2	208	222	310	50	100	8,4
	30.750	LS34LA3	233	236	326	50	100	10,0

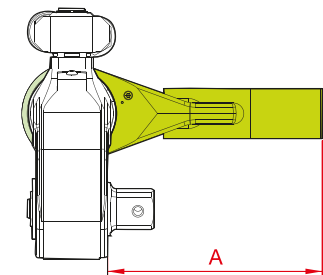
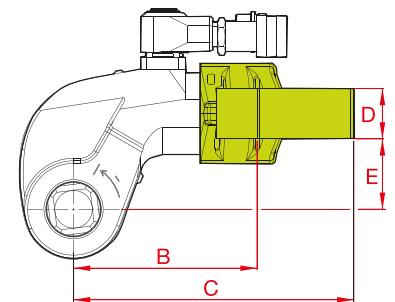
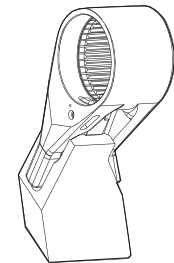

### Reaction Tube Extension

Wrench	Model	A	B	C	D	Weight
Model	LARZEP	mm	mm	mm	mm	kg
LS02	LS02RT	706	152	636	58	4,6
LS04	LS04RT	733	152	647	57	5,5
LS08	LS08RT	747	152	659	65	7,7
LS15	LS15RT	769	152	675	76	11,2
LS34	LS34RT	813	152	685	100	17,3

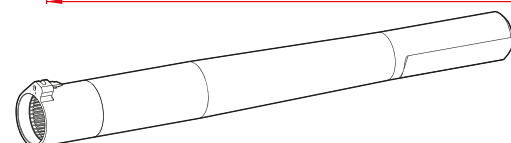
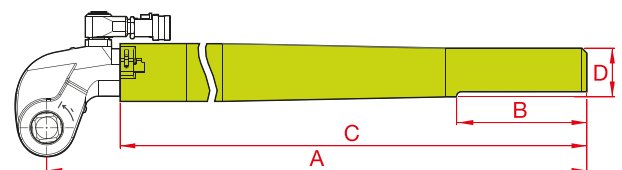



**HEAVY DUTY IMPACT SOCKETS**

Type

**LSS**

Nut

**M14 - M125**

 Hexagon size **22 -180 mm (A/F)**
**HEAVY DUTY IMPACT SOCKETS**

Socket		Square Drive			
Hexagon	Thread	Model	Model	Model	Model
mm (A/F)	ø	3/4"	1"	1 1/2"	2 1/2"
22	M14	LSS07022	-	-	-
24	M16	LSS07024	-	-	-
27	M18	LSS07027	LSS10027	-	-
30	M20	LSS07030	LSS10030	-	-
32	M22	LSS07032	LSS10032	LSS15032	-
36	M24	LSS07036	LSS10036	LSS15036	-
41	M27	LSS07041	LSS10041	LSS15041	-
46	M30	LSS07046	LSS10046	LSS15046	-
50	M33	LSS07050	LSS10050	LSS15050	-
55	M36	LSS07055	LSS10055	LSS15055	LSS25055
60	M39	-	LSS10060	LSS15060	LSS25060
65	M42	-	LSS10065	LSS15065	LSS25065
70	M45	-	LSS10070	LSS15070	LSS25070
75	M48	-	LSS10075	LSS15075	LSS25075
80	M52	-	LSS10080	LSS15080	LSS25080
85	M56	-	LSS10085	LSS15085	LSS25085
90	M60	-	LSS10090	LSS15090	LSS25090
95	M64	-	LSS10095	LSS15095	LSS25095
100	M68	-	-	LSS15100	LSS25100
105	M72	-	-	LSS15105	LSS25105
110	M76	-	-	LSS15110	LSS25110
115	M80	-	-	LSS15115	LSS25115
120	M85	-	-	LSS15120	LSS25120
130	M90	-	-	LSS15130	LSS25130
135	M95	-	-	LSS15135	LSS25135
145	M100	-	-	LSS15145	LSS25145
150	M105	-	-	LSS15150	LSS25150
155	M110	-	-	-	LSS25155
165	M115	-	-	-	LSS25165
175	M120	-	-	-	LSS25175
180	M125	-	-	-	LSS25180



ALLEN KEY DRIVES & SHORT REACTION ARMS

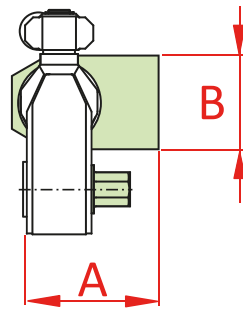

Type **LSA**

Hexagon size **14 - 85 mm (A/F)**

Max. Torque **644 - 34.079 Nm**

Torque Wrench	Allen Drives				Short Reaction Arm		
Model	Model	Hexagon	Max. Torque	Length	Model	A	B
LARZEP	LARZEP	mm	Nm	mm	LARZEP	mm	mm
LS02	LSA0214	14	644	66	LS02SA	67,5	74
	LSA0217	17	1.150	68			
	LSA0219	19	1.605	70			
	LSA0222	22	1.897	73			
	LSA0224	24	1.897	74			
LS04	LSA0417	17	1.150	77	LS04SA	80,0	74
	LSA0419	19	1.605	79			
	LSA0422	22	2.485	82			
	LSA0424	24	3.230	84			
	LSA0427	27	4.336	85			
	LSA0430	30	4.336	87			
	LSA0432	32	4.336	88			
LS08	LSA0817	17	1.150	86	LS08SA	91,5	89
	LSA0819	19	1.605	88			
	LSA0822	22	2.485	91			
	LSA0824	24	3.230	93			
	LSA0827	27	4.600	94			
	LSA0830	30	6.308	96			
	LSA0832	32	7.656	97			
LS15	LSA1530	30	6.308	112	LS15SA	127,5	106
	LSA1532	32	7.656	114			
	LSA1536	36	10.894	117			
	LSA1541	41	14.905	121			
	LSA1546	46	14.905	127			
LS34	LSA3436	36	10.894	140	LS34SA	158,5	135
	LSA3441	41	16.098	144			
	LSA3446	46	22.730	148			
	LSA3450	50	29.194	151			
	LSA3455	55	34.079	154			
	LSA3460	60	34.079	158			
	LSA3465	65	34.079	161			
	LSA3470	70	34.079	164			
	LSA3475	75	34.079	168			
	LSA3485	85	34.079	175			

LSS - LSA TOOLS

**LOW PROFILE HYDRAULIC HEXAGON TORQUE WRENCHES**



- ✓ Designed to tighten and loosen directly nuts requiring accurate high torque during bolt tightening and maximum torque during bolt loosening.
- ✓ Low profile design and small operating radius.
- ✓ Robust and easy to disassemble for maintenance without special tools.
- ✓ Fast release drive unit for quick exchange of cassette.
- ✓ 30° rotation angle and rapid return stroke.
- ✓ Torque accuracy:  $\pm 3\%$  across full stroke.
- ✓ Wide range of interchangeable cassettes, from 30mm to 155mm hexagon.
- ✓ Wide range of hexagonal reducer inserts to extend the range of nut size as option.
- ✓ Wide range of accessories available: Extended Reaction Arms and Reaction Paddles.
- ✓ Several models of HAT torque wrench pumps available.



**HAT**  
Torque Wrench Pump.



P.103



HEXAGONAL TORQUE WRENCHES

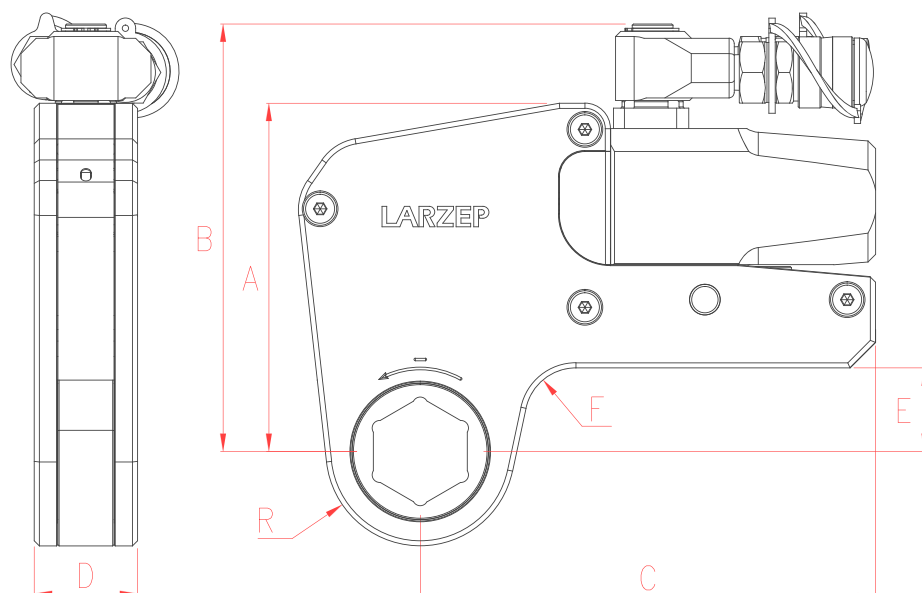

Type **LX**

Torque **2.712 - 47.450 Nm**

Max. pressure **690 bar**

Torque	Drive Unit		Cassette			Dimensions						
	Maximum	Model	Weight	Model	Hexagon	Weight	A	B	C	D	E	F
Nm	LARZEP	kg	LARZEP	mm	kg	mm	mm	mm	mm	mm	mm	mm
2.712	LX03	1,4	LX03H_	30 to 60	2,1-2,3	109	141	148	32	24	20	
5.423	LX06	2,0	LX06H_	36 to 85	3,7-4,5	136	167	178	41	33	20	
10.846	LX11	3,0	LX11H_	50 to 105	7,9-9,3	172	205	208	53	42	25	
20.337	LX21	5,0	LX21H_	65 to 115	13,6-15,1	207	240	253	63	50	20	
30.505	LX31	7,7	LX31H_	75 to 135	21,9-25,0	227	266	297	77	48	35	
47.450	LX47	11,4	LX47H_	80 to 155	31,8-36,7	268	301	345	91	69-73	50	



The wrenches consist of a drive unit (LX\_ ) and an interchangeable hexagonal cassette (LX\_ H\_ ).

**Example:** If you need a torque wrench for 50 mm hexagon with a maximum torque of 5.100 Nm, References to request are **LX06 + LX06H050**.

Extended Reaction Arms

Wrench	Model	A	B	C	Weight
Model	LARZEP	mm	mm	mm	kg
LX03	LX03LA	56	398	76	2,6
LX06	LX06LA	66	436	74	4,6
LX11	LX11LA	85	449	55	7,6
LX21	LX21LA	102	498	72	12,0
LX31	LX31LA	114	524	77	17,3
LX47	LX47LA	127	419	133	17,8

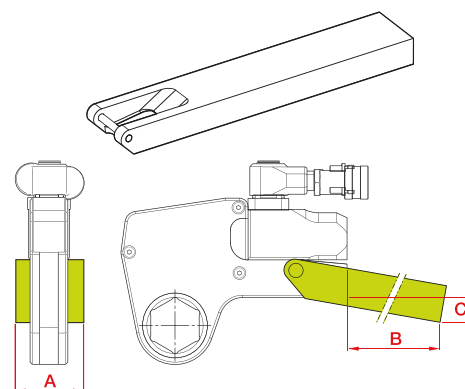

Reaction Paddles

Wrench	Model	A	B	C	D	E	Weight
Model	LARZEP	mm	mm	mm	mm	mm	kg
LX03	LX03SA	84	16	35	45	148	0,4
LX06	LX06SA	109	21	47	59	190	0,8
LX11	LX11SA	137	26	57	69	223	2,0
LX21	LX21SA	165	32	69	87	257	3,9
LX31	LX31SA	207	37	91	134	317	7,2
LX47	LX47SA	225	42	91	182	367	10,6

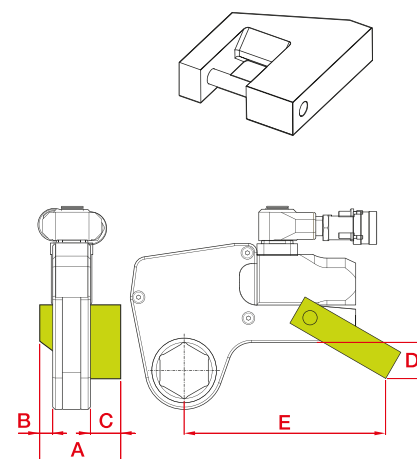

**HEXAGONAL REDUCER INSERTS**

**HEXAGONAL REDUCER INSERTS**

CASSETTES				HEXAGONAL REDUCER INSERTS					
Model	Thread	Hexagon	R	Model	Reducer	Model	Reducer	Model	Reducer
LX03		mm (A/F)	mm	LX03	mm (A/F)	LX03	mm (A/F)	LX03	mm (A/F)
LX03H030	M20	30	31	-	-	-	-	-	-
LX03H032	M22	32	31	-	-	-	-	-	-
LX03H036	M24	36	31	-	-	-	-	-	-
LX03H041	M27	41	34	LX03R041032	41 - 32	LX03R041030	41 - 30	LX03R041024	41 - 24
LX03H046	M30	46	34	LX03R046036	46 - 36	LX03R046032	46 - 32	-	-
LX03H050	M33	50	39	LX03R050041	50 - 41	LX03R050036	50 - 36	-	-
LX03H055	M36	55	42	LX03R055046	55 - 46	LX03R055041	55 - 41	LX03R055036	55 - 36
LX03H060	M39	60	45	LX03R060050	60 - 50	LX03R060046	60 - 46	LX03R060041	60 - 41
				LX03R060036	60 - 36	-	-	-	-

CASSETTES				HEXAGONAL REDUCER INSERTS					
Model	Thread	Hexagon	R	Model	Reducer	Model	Reducer	Model	Reducer
LX06		mm (A/F)	mm	LX06	mm (A/F)	LX06	mm (A/F)	LX06	mm (A/F)
LX06H036	M24	36	37	-	36 - 30	-	-	-	-
LX06H041	M27	41	37	-	41 - 32	-	-	-	-
LX06H046	M30	46	40	-	46 - 36	-	-	-	-
LX06H050	M33	50	42	LX06R050036	50 - 36	-	-	-	-
LX06H055	M36	55	44	LX06R055041	55 - 41	LX06R055036	55 - 36	LX06R055032	55 - 32
LX06H060	M39	60	47	LX06R060050	60 - 50	LX06R060046	60 - 46	LX06R060036	60 - 36
AX06H065	M42	65	50	LX06R065055	65 - 55	LX06R065050	65 - 50	LX06R065046	65 - 46
LX06H070	M45	70	53	LX06R070060	70 - 60	LX06R070055	70 - 65	-	-
LX06H075	M48	75	55	LX06R075065	75 - 65	LX06R075060	75 - 60	LX06R075055	75 - 55
				LX06R075050	75 - 50	-	-	-	-
LX06H080	M52	80	59	LX06R080070	80 - 70	LX06R080065	80 - 65	LX06R080060	80 - 60
				LX06R080055	80 - 55	LX06R080050	80 - 50	-	-
LX06H085	M56	85	62						

CASSETTES				HEXAGONAL REDUCER INSERTS					
Model	Thread	Hexagon	R	Model	Reducer	Model	Reducer	Model	Reducer
LX11		mm (A/F)	mm	LX11	mm (A/F)	LX11	mm (A/F)	LX11	mm (A/F)
LX11H050	M33	50	45	-	-	-	-	-	-
LX11H055	M36	55	48	-	-	-	-	-	-
LX11H060	M39	60	51	-	-	-	-	-	-
LX11H065	M42	65	56	LX11R065050	65 - 50	-	-	-	-
LX11H070	M45	70	56	LX11R070055	70 - 55	-	-	-	-
LX11H075	M48	75	58	LX11R075060	75 - 60	LX11R075055	75 - 55	-	-
LX11H080	M52	80	61	LX11R080065	80 - 65	LX11R080060	80 - 60	LX11R080055	80 - 55
				LX11R080050	80 - 50	-	-	-	-
LX11H085	M56	85	66	LX11R085070	85 - 70	LX11R085065	85 - 65	LX11R085060	85 - 60
				LX11R085055	85 - 55	-	-	-	-
LX11H090	M60	90	74	LX11R090075	90 - 75	-	-	-	-
LX11H095	M64	95	74	LX11R095080	95 - 80	LX11R095075	95 - 75	-	-
LX11H100	M68	100	80						
LX11H105	M72	105	80						



## HEXAGONAL REDUCER INSERTS



CASSETTES				HEXAGONAL REDUCER INSERTS					
Model	Thread	Hexagon	R	Model	Reducer	Model	Reducer	Model	Reducer
LX21		mm (A/F)	mm	LX21	mm (A/F)	LX21	mm (A/F)	LX21	mm (A/F)
LX21H070	M45	70	59	-	-	-	-	-	-
LX21H075	M48	75	62	-	-	-	-	-	-
LX21H080	M52	80	65	LX21R080065	80 - 65	-	-	-	-
LX21H085	M56	85	70	LX21R085070	85 - 70	-	-	-	-
LX21H090	M60	90	75	LX21R090075	90 - 75	-	-	-	-
LX21H095	M64	95	75	LX21R095080	95 - 80	LX21R095075	95 - 75	-	-
LX21H100	M68	100	81	-	-	-	-	-	-
LX21H105	M72	105	81	LX21R105090	105 - 90	-	-	-	-
LX21H110	M76	110	88	LX21R110095	110 - 95	-	-	-	-
LX21H115	M80	115	88	LX21R115100	115 - 100	-	-	-	-

CASSETTES				HEXAGONAL REDUCER INSERTS					
Model	Thread	Hexagon	R	Model	Reducer	Model	Reducer	Model	Reducer
LX31		mm (A/F)	mm	LX31	mm (A/F)	LX31	mm (A/F)	LX31	mm (A/F)
LX31H075	M48	75	67	-	-	-	-	-	-
LX31H080	M52	80	67	LX31R080060	80 - 60	LX31R080055	80 - 55	-	-
LX31H085	M56	85	73	LX31R085065	85 - 65	LX31R085060	85 - 60	-	-
LX31H090	M60	90	78	LX31R090070	90 - 70	LX31R090060	90 - 60	-	-
LX31H095	M64	95	78	LX31R095075	95 - 75	-	-	-	-
LX31H100	M68	100	85	-	-	-	-	-	-
LX31H105	M72	105	85	-	-	-	-	-	-
LX31H110	M76	110	90	-	-	-	-	-	-
LX31H115	M80	115	90	-	-	-	-	-	-
LX31H120	M85	120	95	-	-	-	-	-	-
LX31H130	M90	130	100	-	-	-	-	-	-
LX31H135	M95	135	100	LX31R135105	135 - 105	-	-	-	-

CASSETTES				HEXAGONAL REDUCER INSERTS					
Model	Thread	Hexagon	R	Model	Reducer	Model	Reducer	Model	Reducer
LX47		mm (A/F)	mm	LX47	mm (A/F)	LX47	mm (A/F)	LX47	mm (A/F)
LX47H080	M52	80	129	LX47R080050	80 - 50	-	-	-	-
LX47H085	M56	85	129	-	-	-	-	-	-
LX47H090	M60	90	135	LX47R090060	90 - 60	-	-	-	-
LX47H095	M64	95	135	-	-	-	-	-	-
LX47H100	M68	100	139	-	-	-	-	-	-
LX47H105	M72	105	139	-	-	-	-	-	-
LX47H110	M76	110	146	LX47R110085	110 - 85	-	-	-	-
LX47H115	M80	115	146	-	-	-	-	-	-
LX47H120	M85	120	153	LX47R120095	120 - 95	-	-	-	-
LX47H130	M90	130	160	LX47R130105	130 - 105	-	-	-	-
LX47H135	M95	135	160	LX47R135110	135 - 110	-	-	-	-
LX47H140	M95	140	163	LX47R140115	140 - 115	-	-	-	-
LX47H145	M100	145	163	LX47R145120	145 - 120	-	-	-	-
LX47H150	M105	150	169	-	-	-	-	-	-
LX47H155	M110	155	169	LX47R155130	155 - 130	-	-	-	-



**PORTABLE PUNCHING HEADS**

Type

**PH**

Capacity

**15 - 45 Tn**

Max. pressure

**700 bar**
**PORTABLE PUNCHING HEADS**

- ✓ Direct punching hydraulic machine designed for round, square or oblong punched holes in mild steel plate.
- ✓ Lightweight, easy transport and handling, especially in confined spaces.
- ✓ Provided with a male ball quick coupler AZ3321.
- ✓ Used in electric conducting towers, metallic structures, bridges, etc.
- ✓ For punches on all type of plates I-L-T. Depending on material, indicate if 14% or 8% inclination punchers are needed.
- ✓ Material thickness depends on its hardness and should not exceed hole diameter. Up to 12,7 mm thickness in mild steel.
- ✓ Material maximum strength: 37 kg/mm<sup>2</sup>.
- ✓ Puncher and dies are not included in the tool. Order them indicating required diameter.

Capacity	Model	Punching ø min - max	Maximum Thickness	Distance to edge	Dimensions	Weight
Tn	LARZEP	mm	mm	mm	mm	kg
<b>15</b>	<b>PH015</b>	6 - 18	7	40	80 x 170 x 280	8,5
<b>35</b>	<b>PH035</b>	6,4 - 20,6	12,7	70	120 x 250 x 360	15,0
<b>45</b>	<b>PH045</b>	8 - 24	16	110	150 x 360 x 450	40,0



Always read the safety instructions.

HYDRAULIC CRIMPING TOOLS



Type	<b>CB - CH - CM</b>
Capacity	<b>5 - 100 Tn</b>
Max. pressure	<b>700 bar</b>

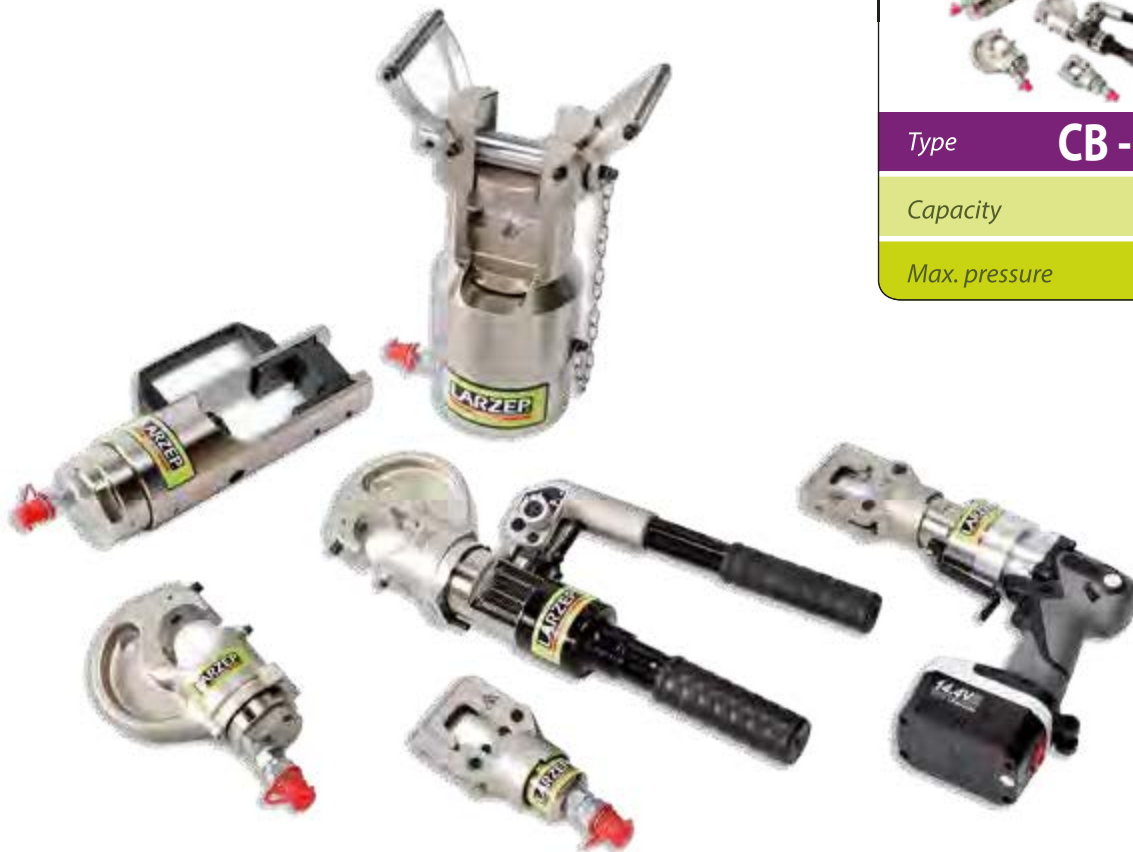

- ✓ Models up to 20 Tn: Hydraulic compression tools for low voltage terminals and sleeves.
- ✓ Models from 50 to 100 Tn: Hydraulic compression tools for medium and high voltage aluminium and steel terminals and sleeves.
- ✓ Three types of hydraulic crimping tools are available: self contained (CM), battery powered (CB) or crimping head only (CH).
- ✓ With audible safety valve to limit the crimping force. Models up to 20 Tn.
- ✓ Maximum working pressure 700 bar, except CB005 model: 450 bar.
- ✓ Dies are interchangeable between models of the same capacity. Dies are not included in the tool. Order them indicating the required section and material.
- ✓ Box included for easy transport and tool protection.



Self Contained CM



Crimping Head CH



Battery Powered CB

## CRIMPING HEADS

- ✓ CH, hydraulic compression head, with AZ3321 quick coupler to connect to a hydraulic pump with a maximum working pressure of 700 bar.
- ✓ Models from 5 to 100 Tn.
- ✓ CH050D and CH100D are double acting models.
- ✓ Applications for 50 and 100 Tn models:  
Compression clamps and sleeves for:  
Aluminium conductors steel reinforced (ACSR),  
Aluminium conductors (AAC),  
Aluminium alloy conductors (AAAC),  
Aluminium conductors alloy reinforced (ACAR).

Capacity		Model	Oil Cap.	Stroke	ø max. connector	Dimensions	Weight
Tn	kN	LARZEP	cm <sup>3</sup>	mm	mm	mm	kg
5	55	CH005	50	15	25	185 x 75	1,5
12	120	CH012	50	25	35	240 x 85	2,7
		CH012C	50	25	35	225 x 130	3,2
20	200	CH020	50	45	58	345 x 140	8,5
50	500	CH050	303	38	60	350 x ø140	17,0
		CH050D	303	38	60	350 x ø140	17,0
100	1.000	CH100	314	22	75	365 x ø190	40,0
		CH100D	314	22	75	365 x ø190	40,0



## SELF-CONTAINED CRIMPING TOOLS

- ✓ CM, hydraulic compression tool with integral pump.
- ✓ Models from 5 to 20 Tn.
- ✓ With 180° rotating head.
- ✓ CM005 model lightweight and compact. Ideal for use in confined spaces.
- ✓ CM012 model, suitable for deep indenting underground lines (16 - 240 mm<sup>2</sup>), as well as other general compression applications. Adaptors available.
- ✓ Two-stage CM012C model, a fast speed for terminal fixing and a slow one for the crimping action.

Capacity		Model	Stroke	ø max. connector	Dimensions	Weight
Tn	kN	LARZEP	mm	mm	mm	kg
5	55	CM005	15	25	350 x 120	2,4
12	120	CM012	25	35	480 x 160	4,3
		CM012C	25	35	470 x 160	5,5





Type **CB - CH - CM**

Capacity **5 - 100 Tn**

Max. pressure **700 bar**

### BATTERY POWERED CRIMPING TOOLS

- ✓ CB, electro hydraulic portable tool with rechargeable battery and quick retract mechanism.
- ✓ Models from 5 to 20 Tn.
- ✓ With 180° rotating head.
- ✓ Two-stage CB012 model, suitable for deep indenting underground lines (16 - 240 mm<sup>2</sup>), as well as other general compression applications. Adaptors available.
- ✓ Supplied with 2 batteries 18V - 4 A·h, 1 charger and 1 safety belt.

Capacity		Model	Oil Cap.	Stroke	∅ max. connector	Dimensions	Weight
Tn	kN	LARZEP	cm <sup>3</sup>	mm	mm	mm	kg
5	55	CB005	100	16	25	315 x 230	3,4
12	120	CB012	100	25	35	350 x 280	6,4
		CB012C	100	25	35	380 x 280	6,6

Battery (Ref. CBB)				Charger (Ref. CBC)	
Voltage	Li-ion	Battery Life	Max. compression duration	Input	Output
18V	4 Ah	<b>91 compressions</b> (Cu 150mm <sup>2</sup> )	CB005: 6 sec. - CB012: 11 sec. CB012C: 10 sec.	100 - 240 VAC 50 - 60 Hz	18VDC 4 Ah



### MAXIMUM SECTION FOR APPLICATIONS

Model	Sleeves and preinsulated terminals				Sleeves and terminals
	MJPT	MJB	CPTA	CPTAU	Standard Cu
LARZEP	mm <sup>2</sup> (mcm)	mm <sup>2</sup>	mm <sup>2</sup> (mcm)	mm <sup>2</sup> (mcm)	mm <sup>2</sup> (mcm)
CM005 - CH005	150 (350)	25 (#2)	150 (350)	150 (350)	240 (500)
CB005	150 (350)	25 (#2)	150 (350)	150 (350)	240 (500)
CB012, CH012, CM012	150 (350)	25 (#2)	150 (350)	150 (350)	400 (750)
CB012C, CH012C, CM012C	150 (350)	25 (#2)	150 (350)	150 (350)	400 (750)
CH020	150 (350)	25 (#2)	150 (350)	150 (350)	630 (1.250)

Model	Tubular Al	Tubular Cu	Connectors	Bimetallic terminal
		DIN 46235	'C' Type	Norm EDF HN-68-S-90
LARZEP	mm <sup>2</sup> (mcm)	mm <sup>2</sup> (mcm)	mm <sup>2</sup> (mcm)	mm <sup>2</sup> (mcm)
CM005 - CH005	150 (350)	185 (400)	50/50 (2/0-2/0)	-
CB005	150 (350)	185 (400)	50/50 (2/0-2/0)	-
CB012, CH012, CM012	300 (600)	185 (400)	185 (400)	240 (500)
CB012C, CH012C, CM012C	300 (600)	185 (400)	185 (400)	-
CH020	500 (1.000)	240 (500)	185 (400)	630 (1.250)

## AUTOMOTIVE

**LARZEP** offers a wide range of jacks and automotive products including:











Bottle jacks, High lift transmission jacks, Trolley jacks, Portable cranes, Hydraulic tables, Air service jacks, High tonnage air service jacks, Pipe benders, Presses and Maintenance units.

- ✓ Bottle jacks from 2 to 50 Tn. Also available telescopic jacks.
- ✓ High lift transmission jacks have 4 wheels for easy manoeuvrability.  
The adaptable head allows a variety of jobs to be undertaken safely.
- ✓ Trolley jacks have a precise control during lifting or lowering operations.
- ✓ Portable cranes with an extendable jib to increase reach and with polyamide wheels and swivel rear castor for easy movement.
- ✓ Lifting tables can be blocked at different heights with safety pins.
- ✓ Three telescopic air service jacks available as standard. Easy to operate, with the control located at the end of the handle and with three-position handle to place the jack under the load safely.
- ✓ High tonnage air service jacks from 30 to 150 Tn with one, two or three stages. Easy to operate, with the control located at the end of the handle and with three-position handle to place the jack under the load safely.
- ✓ Pipe benders suitable for carrying out operations with plumbing pipes from 1/2" to 3".  
Built-in pump as standard.
- ✓ Presses from 10 to 250 Tn with strong bench mount frame (EC models 10 and 20 Tn) or floor mounted H frame. Available with electric, air hydraulic or hand pump.
- ✓ Maintenance unit designed for operations such as pushing, separating, joining, lifting, compressing, stretching and fixing.



# AUTOMOTIVE



Models	Tool type	Capacity Tn		Page
<b>A - AB</b>	Bottle Jacks	2-50		<b>158</b>
<b>AF</b>	High Lift Transmission Jacks	0,3-1,5		<b>160</b>
<b>B</b>	Trolley Jacks	2-20		<b>161</b>
<b>DLR</b>	Portable Cranes	0,65-2,0		<b>162</b>
<b>F</b>	Lifting Tables	0,65-2,5		<b>163</b>
<b>HN</b>	Air Service Jacks	30-80		<b>164</b>
<b>HL</b>	High Tonnage Air Service Jacks	60-150		<b>166</b>
<b>VA- VB</b>	Pipe Benders	1/2-3 inch		<b>168</b>
<b>EC-EE-EM-EZ</b>	Presses	10-250		<b>169</b>
<b>CA</b>	Maintenance Set	10		<b>172</b>



**BOTTLE JACKS**

- ✓ From 2 to 50 Tn.
- ✓ Up to 30 Tn 'A' Models are single stage with screw extension.
- ✓ 'AB' versions are telescopic with two hydraulic extensions.
- ✓ All models include safety relief valve.
- ✓ Supplied with zinc plated handle and individual cardboard box.
- ✓ Bottle jacks will operate horizontally, provided that the pump element is at the lowest point.



**BOTTLE JACKS**



Bottle jack with lock nut



50 Tn, 2 speed,  
long stroke bottle jack



Type	<b>A - AB</b>
Capacity	<b>2 - 50 Tn</b>
Max. pressure	<b>700 bar</b>



Larzep designs and manufactures special bottle jacks upon request.

**BOTTLE JACKS - A**

Capacity	Model	A	B	C	D	Screw E	Weight
Tn	LARZEP	mm	mm	mm	mm	mm	kg
2	A10210	168	338	105	118x75	65	3,6
3	A10310	168	338	105	118x75	65	3,7
5	A10515	212	437	150	125x75	75	4,5
8	A10815	219	444	150	145x90	75	6,2
10	A11015	219	444	150	145x90	75	6,4
15	A11515	228	453	150	165x110	75	8,8
20	A12015	234	459	150	173x122	75	10,6
30	A13015	242	467	150	196x142	75	15,5
50	A25014	216	361	145	180x190	-	19,9

**TELESCOPIC BOTTLE JACKS - AB**

Capacity	Model	A	B	C	D	Weight
Tn	LARZEP	mm	mm	mm	mm	kg
5	AB10530	215	515	300	110 x 165	8,5
12	AB11232	245	571	326	144 x 196	15,5

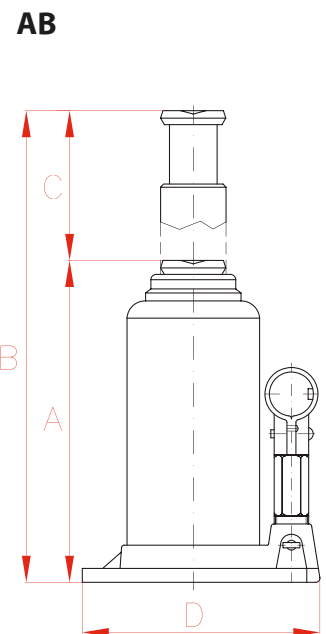
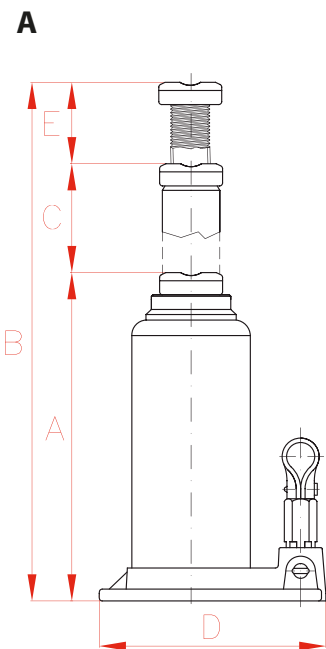

**HIGH LIFT TRANSMISSION JACKS**



Type

**AF**

Capacity

**300 - 1.500 kg**

Max. pressure

**700 bar**

**HIGH LIFT TRANSMISSION JACKS**



- ✓ From 300 to 1.500 kg lifting capacity.
- ✓ Hand operated release valve. Dead Man system.
- ✓ 4 swivel castor wheels for easy manoeuvrability.
- ✓ Foot operated pump keeps hands free.
- ✓ Packed in strong cardboard box.
- ✓ An adaptable head allows a variety of jobs to be undertaken safely.

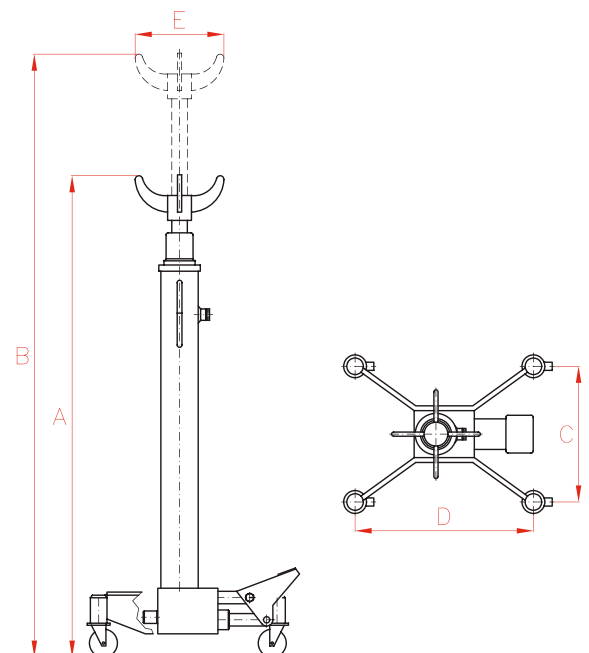

Capacity	Model	A	B	C	D	E	Weight
kg	LARZEP	mm	mm	mm	mm	mm	kg
300	<b>AF30085</b>	1.200	1.990	610	610	320	22
750	<b>AF75082</b>	1.170	1.930	720	720	320	30
1.200	<b>AF120082</b>	1.170	1.925	720	720	320	32
1.500	<b>AF150080</b>	1.150	1.930	550	610	380	60

**AF - BAUTOMOTIVE**



Always read the safety instructions.

TROLLEY JACKS

TROLLEY JACKS



Type	<b>B</b>
Capacity	2 - 20 Tn
Max. pressure	700 bar



- ✓ From 2 to 20 Tn.
- ✓ Two wide wheels to support the load and swivel castor wheels for easy manoeuvrability.
- ✓ Handle features integral safety release mechanism to prevent accidental release.
- ✓ Safe and precise control during lifting or lowering operations.
- ✓ Foot pedal to provide quick approach.
- ✓ Safety valve to prevent accidental overpressure.
- ✓ End of stroke limiting valve.

Capacity	Stroke	Model	A	B	C	D	E	F	Weight
Tn	mm	LARZEP	mm	mm	mm	mm	mm	mm	kg
2	380	<b>B02038</b>	90	470	905	135	270	870	30
3	380	<b>B03038</b>	90	470	905	135	270	870	34
7	410	<b>B06041</b>	170	580	1.310	220	414	965	81
10	435	<b>B10043</b>	170	605	1.600	270	414	995	121
15	405	<b>B15041</b>	195	600	1.750	265	375	1.105	145
20	415	<b>B20041</b>	200	615	1.777	310	415	1.122	235

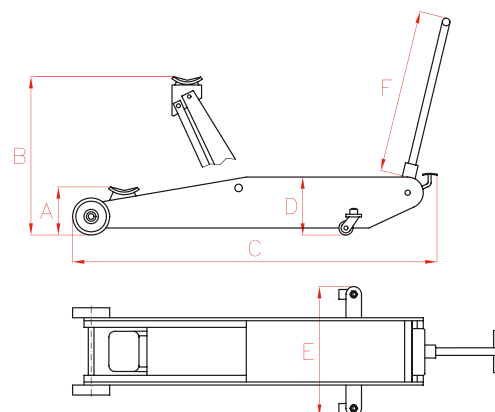

**PORTABLE CRANES**



Type

**DLR**

Capacity

**650 - 2.000 kg**

Max. pressure

**700 bar**

**PORTABLE CRANES**



- ✓ From 650 to 2.000 kg lifting capacity.
- ✓ Polyamide wheels and swivel rear castor for easy movement.
- ✓ Exceptionally versatile due to their compact dimensions when folded up.
- ✓ Fitted with a safety relief valve to prevent overloading.
- ✓ All models are fitted with an extendable jib to increase reach.
- ✓ Special lowering valve in all models for safer and better control of descent.
- ✓ If the knob is released accidentally, the arm stops.

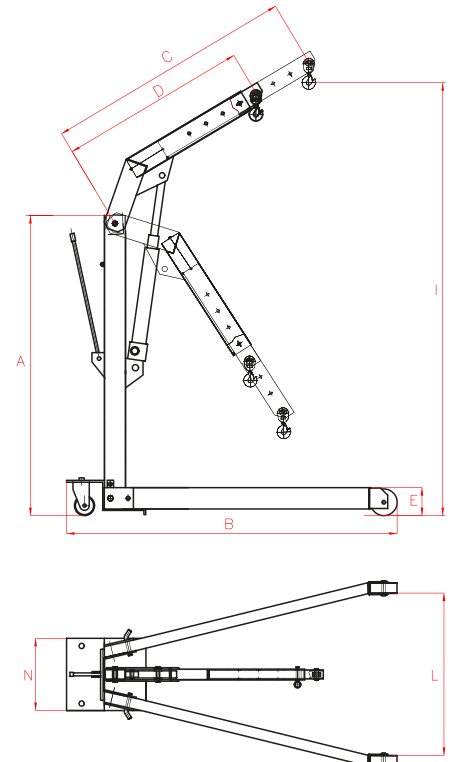

Model	4 / 3 / 2 / 1 Jib position
LARZEP	kg
<b>DLR006</b>	650 - 550 - 450 - 350
<b>DLR010</b>	1.000 - 900 - 800 - 700
<b>DLR020</b>	2.000 - 1.750 - 1.650 - 1.250

Capacity	Model	A	B	C	D	E	I	L	N	Weight
kg	LARZEP	mm	mm	mm	mm	mm	mm	mm	mm	kg
<b>650</b>	<b>DLR006</b>	1.580	1.480	1.300	960	112	2.200	820	530	83
<b>1.000</b>	<b>DLR010</b>	1.580	1.580	1.300	960	112	2.200	970	530	99
<b>2.000</b>	<b>DLR020</b>	1.740	1.920	1.610	1.200	150	2.460	1.080	700	175

**DLR - F AUTOMOTIVE**



LIFTING TABLES

LIFTING TABLES



Type	<b>F</b>
Capacity	<b>650 - 2.500 kg</b>
Max. pressure	<b>700 bar</b>



- ✓ Single lift, from 650 to 2.500 kg lifting capacity.
- ✓ A foot pedal is fitted to advance the lifting table quickly to contact the load. The operating handle is then used to lift the load.
- ✓ Special lowering valve for a safe and controlled movement. Overload safety relief valve.
- ✓ Operating handle facilitates easier operation.
- ✓ The table can be locked at different heights with safety pins.
- ✓ Polyamide duty swivel castors for easy manoeuvrability.
- ✓ The frame is in accordance with lifting table security standards.

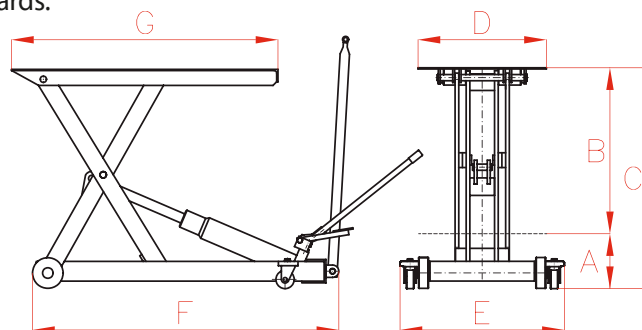

Capacity	Model	A	B	C	D	E	F	G	Weight
kg	LARZEP	mm	mm	mm	mm	mm	mm	mm	kg
650	<b>F00643</b>	215	430	645	500	645	1.060	830	72
1.500	<b>F01567</b>	210	670	880	500	690	1.380	1.020	136
2.500	<b>F02558</b>	300	580	880	540	795	1.440	1.060	188



## AIR SERVICE JACKS



- ✓ From 30 to 80 Tn.
- ✓ Telescopic models with two and three stages.
- ✓ Operated by an air/hydraulic pump. Air pressure required: 8 to 12 bar.
- ✓ Ram return is automatic. Constant and controlled speed under load, can be increased without load.
- ✓ Check valves guarantee load holding, even if an air or oil pipe is accidentally broken.
- ✓ Equipped with an overpressure safety valve as protection against overloading.
- ✓ Three-position handle can be lowered to place the jack under the load.
- ✓ A hardened serrated load saddle and extension pieces of 70 and 120 mm are supplied as standard.
- ✓ Easy to operate, with the control at the end of handle.

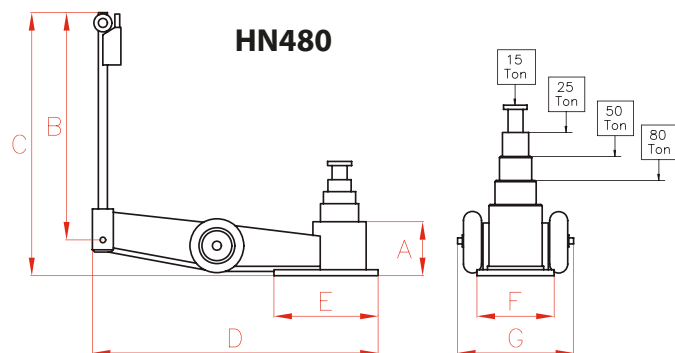
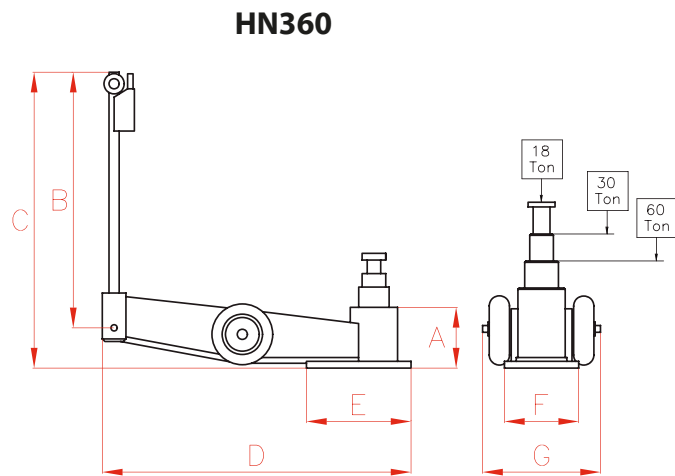
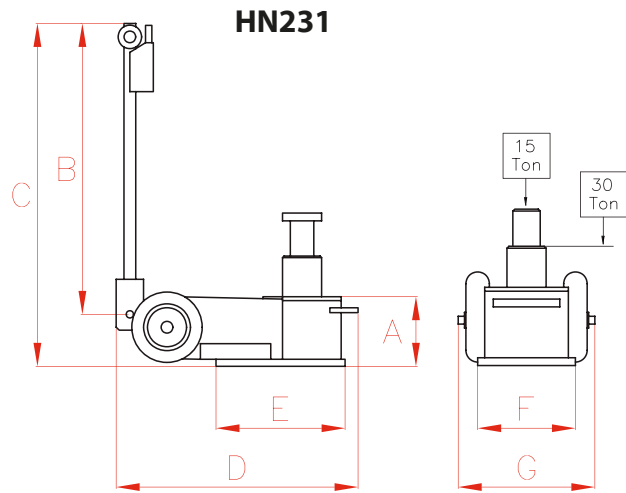

Type	<b>HN</b>
Capacity	<b>30 - 80 Tn</b>
Max. pressure	<b>8 - 12 bar</b>



Easy to operate, with the controls at the end of the handle.



Extension pieces of 70 and 120 mm are supplied as standard.

Capacity	Stroke	Model	A	B	C	D	E	F	G	Weight
Tn	mm	LARZEP	mm	mm	mm	mm	mm	mm	mm	kg
<b>15/30</b>	88+83	<b>HN231</b>	150	1.315	1.400	525	270	206	300	39
<b>18/30/60</b>	91+72+74	<b>HN360</b>	180	1.310	1.395	980	320	240	350	70
<b>15/25/50/80</b>	66+56+68+60	<b>HN480</b>	180	1.310	1.395	980	320	240	350	78

## HIGH TONNAGE AIR SERVICE JACKS

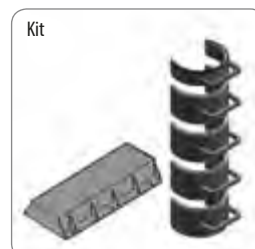

- ✓ From 60 to 150 Tn.
- ✓ Models with one stage and telescopic with two and three stages.
- ✓ Operated by an air/hydraulic pump. Air pressure required: 8 to 12 bar. Air inlet port: 1/2" BSP.
- ✓ Dual descent valve for greater control.
- ✓ Fitted with self sealing pneumatic tyres for easy manoeuvrability.
- ✓ Special hooks for transport.
- ✓ Automatic ram return. Constant and controlled speed under load, can be increased without load.
- ✓ Check valves guarantee load holding, even if an air or oil pipe is accidentally broken.
- ✓ Equipped with an overpressure safety valve as protection against overloading.
- ✓ Three-position handle can be lowered to place the jack under the load.
- ✓ Easy to operate, with the control at the end of the handle.
- ✓ Wide range of optional accessories: remote pendant, manual emergency pump, safety load blocks, safety block holder, safety blocks kit, extensions and extension holder.

HL06022

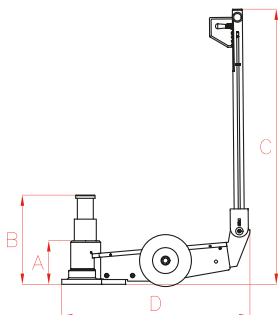

HL08052

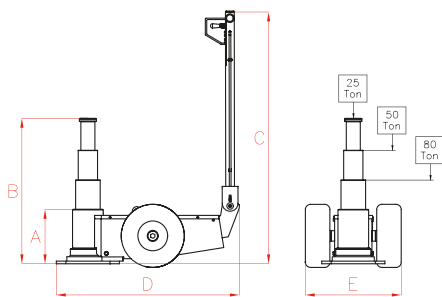

HL08042

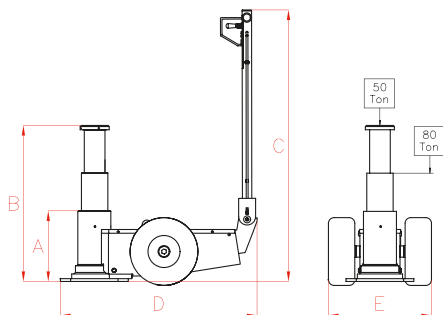

HL10044

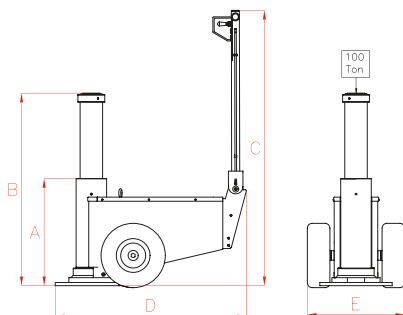

HL15055

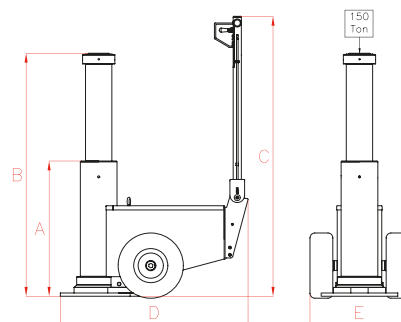

Type **HL**

Capacity **60 - 150 Tn**

Max. pressure **8 - 12 bar**

Capacity	Stroke	Model	A	B	C	D	E	Weight
Tn	mm	LARZEP	mm	mm	mm	mm	mm	kg
30/60	110+117	<b>HL06022</b>	220	447	1.385	940	460	93
50/80	196+222	<b>HL08042</b>	420	838	1.440	1.039	540	161
25/50/80	167+171+180	<b>HL08052</b>	341	859	1.440	1.040	540	143
100	445	<b>HL10044</b>	725	1.170	1.720	1.180	610	290
150	554	<b>HL15055</b>	900	1.454	1.720	1.250	620	385

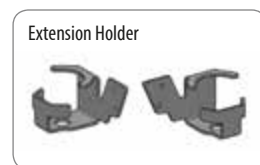

ACCESSORIES (Optional)

Model	Extension Holder		Extensions						
	Right	Left	10 mm	70 mm	120 mm	150 mm	200 mm	250 mm	300 mm
HL06022	-	-	HLE06001	HLE06007	HLE06012	-	-	-	-
HL08042	HLT080R	HLT080L	-	-	-	HLE08015	-	HLE08025	HLE08030
HL08052	HLT080R	HLT080L	-	-	-	HLE08015	-	HLE08025	HLE08030
HL10044	HLT150R	HLT150L	-	-	-	-	HLE15020	HLE15025	HLE15030
HL15055	HLT150R	HLT150L	-	-	-	-	HLE15020	HLE15025	HLE15030

\*Safety blocks kit HLS100: HLB05017M + 3x HLB10017M + HLB10017F + HLC100  
 \*Safety blocks kit HLS150: HLB05021M + 4x HLB10021M + HLB10021F + HLC150

Model	Safety Blocks				
	50mm M/F	100mm M/F	100mm F/F	Holder	Kit*
HL06022	-	-	-	-	-
HL08042	HLB05017M	HLB10017M	HLB10017F	HLC100	HLS100
HL08052	HLB05017M	HLB10017M	HLB10017F	HLC100	HLS100
HL10044	HLB05017M	HLB10017M	HLB10017F	HLC100	HLS100
HL15055	HLB05021M	HLB10021M	HLB10021F	HLC150	HLS150

Model	Remote Pendant	Manual Pump
All models	HLR	HLH



**PIPE BENDERS**



Type

**VA - VB**

Capacity

1/2 - 3 inch

Max. pressure

700 bar

**PIPE BENDERS**



- ✓ Suitable for carrying out bending operations with plumbing pipes DIN 2440 and DIN2441.
- ✓ Pipe bending capacities of up to 2" and 3" NB.
- ✓ Maximum bending angle: 180°.
- ✓ Built-in pump models VA and VB.
- ✓ Equipped with a safety relief valve to prevent overpressure.
- ✓ Delivered in storage box.
- ✓ VB1527 model equipped with a tripod stand.

**HYDRAULIC PIPE BENDERS**

Pipe	Model	Capacity	Stroke	Tripod Stand	Weight
"	LARZEP	Tn	mm	*	kg
1/2" - 2"	<b>VB1527</b>	15	270	*	45
1/2" - 3"	<b>VA2034</b>	20	340	-	90

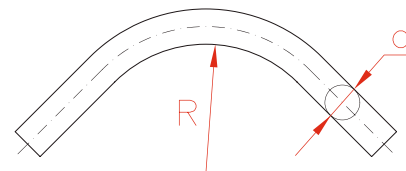

**BENDING SHOES VB1527 (up to 2") and VA2034 (up to 3")**

Nominal Bore	1/2"	3/4"	1"	1 1/4"	1 1/2"	2"	2 1/2"	3"
External diameter d (mm)	21,3	26,9	33,7	42,4	48,3	60,3	76,1	88,9
Maximum Wall Thickness (mm) Pipe DIN-2440	2,65	2,65	3,25	3,25	3,25	3,65	3,65	4,05
Maximum Wall Thickness (mm) Pipe DIN-2441	3,25	3,25	4,05	4,05	4,05	4,5	4,5	4,85
Bend Radius R (mm)	83	114	146	184	210	241	290	350

VA - VB AUTOMOTIVE



PRESSES



Type **EC - EE - EM -EZ**

Size **10 - 250 Tn**

Max. pressure **700 bar**



- ✔ Extremely sturdy frames, made from welded steel profiles, available as bench mount (EC series) and floor mounted H-Frame models.
- ✔ Models are available powered by hand pump, air/hydraulic pump or electric/hydraulic pump. CE versions are fitted with remote motor control.
- ✔ Table height is adjustable on floor mounted models, manually on 30 Tn, winch on 60 Tn and 120 Tn models and hydraulically from the main ram on 250 Tn models.
- ✔ V-blocks and a pressure gauge reading in tons are supplied as standard on all models.
- ✔ The hydraulic cylinder on the ECM and ECZ bench presses can be easily removed and used in other applications.
- ✔ On the 30 Tn EM and EZ presses, the hydraulic cylinder is equipped with a screw extension designed to minimise the pumping action required.
- ✔ The EM models incorporate a two-speed hand pump for quick approach of the piston to the work piece.



V-blocks and pressure gauge reading in tons are supplied as standard on all models.



Larzep designs and manufactures special presses upon request.



Capacity	Frame		E	H max.	Stroke	Model	Pump Type			
Tn	Bench Mount	Floor Mount	mm	mm	mm	LARZEP	Hand	Electric	Air	Model
10	*	-	350	352	130	ECM01113	*	-	-	W10707
	*	-	350	352	130	ECZ01113	-	-	*	Z12107
	*	-	350	352	130	ECE01113	-	*	-	HBM7224
	*	-	350	352	130	ECE01113-CE	-	*	-	HBM7224B
20	*	-	500	376	159	ECM02015	*	-	-	W10707
	*	-	500	376	159	ECZ02015	-	-	*	Z12107
	*	-	500	376	159	ECE02015	-	*	-	HBM7224
	*	-	500	376	159	ECE02015-CE	-	*	-	HBM7224B
30	-	*	500	930	95	EM03012	*	-	-	W00807
	-	*	500	930	95	EZ03012	-	-	*	Z12107
	-	*	500	930	160	EE03116	-	*	-	HBM7244
	-	*	500	930	160	EE03116-CE	-	*	-	HBM7244B
60	-	*	860	935	180	EM06018	*	-	-	W23007
	-	*	860	935	180	EZ06018	-	-	*	Z12107
	-	*	860	935	180	EE06018	-	*	-	HBM7244
	-	*	860	935	180	EE06018-CE	-	*	-	HBM7244B
120	-	*	880	910	180	EZ12018	-	-	*	Z24007
	-	*	880	910	180	EE12018	-	*	-	HBM7244
	-	*	880	910	180	EE12018-CE	-	*	-	HBM7244B
250	-	*	1.080	1.000	300	EE25030-CE	-	*	-	HBM5544B

Model	A	B	C	D	E	F	H min	H max.	I	K	M	N	O
LARZEP	mm	mm	mm	mm	mm	mm	mm	mm	mm	mm	mm	mm	mm
ECM01113	720	440	220	80	350	170	-	352	80	-	400	198	12
ECZ01113	720	440	220	80	350	170	-	352	80	-	400	198	12
ECE01113	720	440	220	80	350	170	-	352	80	-	400	198	12
ECE01113-CE	720	440	220	80	350	170	-	352	80	-	400	198	12
ECM02015	903	610	325	120	500	240	-	376	140	-	570	285	12
ECZ02015	903	610	325	120	500	240	-	376	140	-	570	285	12
ECE02015	903	610	325	120	500	240	-	376	140	-	570	285	12
ECE02015-CE	903	610	325	120	500	240	-	376	140	-	570	285	12
EM03012	1.780	698	650	125	500	245	30	930	140	120	280	150	27
EZ03012	1.780	698	650	125	500	245	30	930	140	-	280	150	27
EE03116	1.780	698	650	125	500	245	30	930	140	275	280	150	27
EE03116-CE	1.780	698	650	125	500	245	30	930	140	275	280	150	27
EM06018	1.960	1.150	800	205	860	385	110	935	260	150	237	165	41
EZ06018	1.960	1.150	800	205	860	385	110	935	260	-	237	165	41
EE06018	1.960	1.150	800	205	860	385	110	935	260	275	237	165	41
EE06018-CE	1.960	1.150	800	205	860	385	110	935	260	275	237	165	41
EZ12018	2.010	1.240	800	308	880	510	80	910	300	-	277	165	51
EE12018	2.010	1.240	800	308	880	510	80	910	300	275	277	165	51
EE12018-CE	2.010	1.240	800	308	880	510	80	910	300	275	277	165	51
EE25030-CE	2.256	1.640	1.000	318	1.080	486	100	1.000	487	-	130	225	80



	Cylinder type				Oil Cap. cm <sup>3</sup>	Advance speed*		Weight kg	Model
	S/A	D/A	Screw	Model		Fast	Slow		
*	-	-	-	KC01113	214	-	1,7	41	ECM01113
*	-	-	-	KC01113	214	-	1,8	42	ECZ01113
*	-	-	-	KC01113	214	31,0	5,8	75	ECE01113
*	-	-	-	KC01113	214	31,0	5,8	80	ECE01113-CE
*	-	-	-	SM02315	528	5,5	0,9	85	ECM02015
*	-	-	-	SM02315	528	-	1,2	90	ECZ02015
*	-	-	-	SM02315	528	21,0	3,9	150	ECE02015
*	-	-	-	SM02315	528	21,0	3,9	155	ECE02015-CE
*	-	65	-	SM03012	419	2,9	0,4	120	EM03012
*	-	65	-	SM03012	419	-	0,6	121	EZ03012
-	*	-	-	D03016	707	11,3	2,1	135	EE03116
-	*	-	-	D03016	707	11,3	2,1	140	EE03116-CE
*	-	-	-	SM06018	1.558	1,5	0,2	455	EM06018
*	-	-	-	SM06018	1.558	-	0,4	456	EZ06018
-	*	-	-	D06018	1.558	5,7	1,0	480	EE06018
-	*	-	-	D06018	1.558	5,7	1,0	485	EE06018-CE
-	*	-	-	D12018	3.180	-	0,2	720	EZ12018
-	*	-	-	D12018	3.180	2,8	0,5	750	EE12018
-	*	-	-	D12018	3.180	2,8	0,5	755	EE12018-CE
-	*	-	-	D25030	10.390	4,3	1,0	2.100	EE25030-CE

Advance speed  
 \* Hand Pump (mm/stroke)  
 \* Electric Pump (mm/sec.)  
 \* Air Pump (mm/sec.)

10 and 20 Tn PRESSES

30, 60, 120 and 250 Tn PRESSES

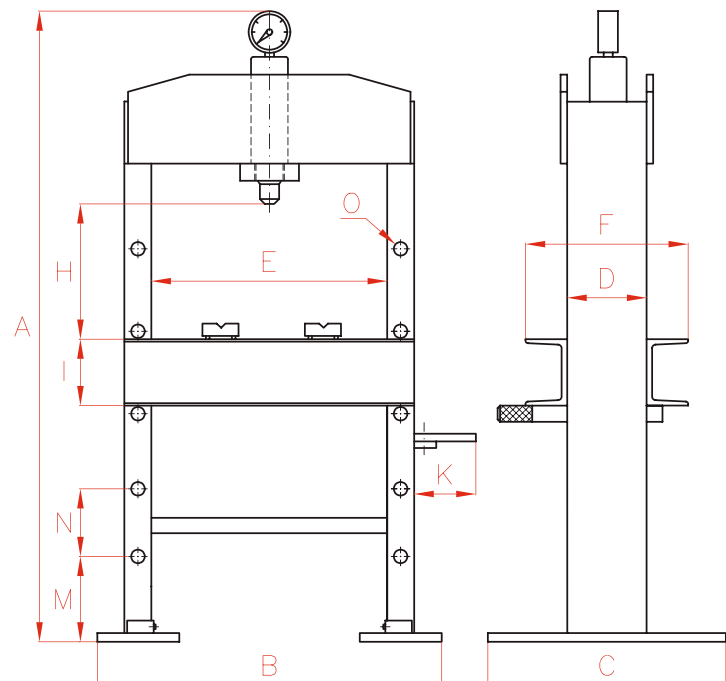
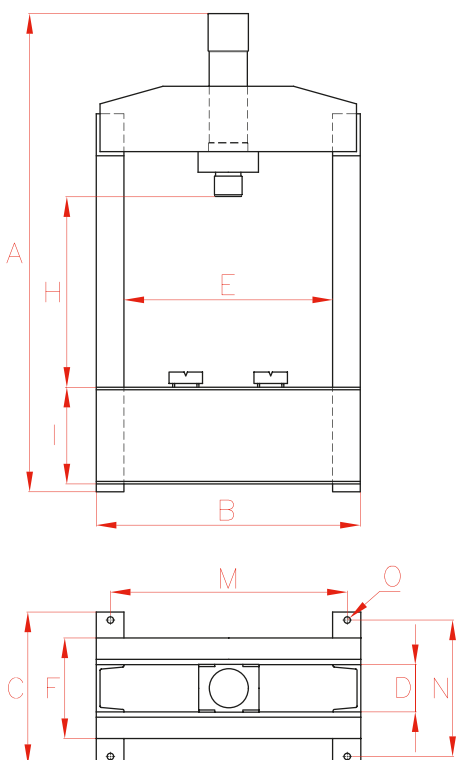

**MAINTENANCE SET**



- ✓ Made of a series of attachments that combined with the pump, cylinder and hose, enable configuration of specific tools designed for various operations such as pushing, separating, joining, lifting, compressing, stretching and fixing.
- ✓ 10 Tn model available.
- ✓ Supplied in a storage/transport case.



**WARNING**

The cylinder provides the indicated nominal force, but as some attachments can induce cylinder side loading, the unit can only be used at 50% of its capacity, at a **MAXIMUM WORKING PRESSURE of 350 bar.**

Capacity	Model	A	B	C	D	E	R	Weight
Tn	LARZEP	mm	mm	mm	mm	mm	mm	kg
10	KC01014	332	135	467	60	M56x2	M42x2,5	4,5
5	T00514*	311	138	449	60	M56x2	M42x2,5	4,0

\* Optional



Always read the safety instructions.

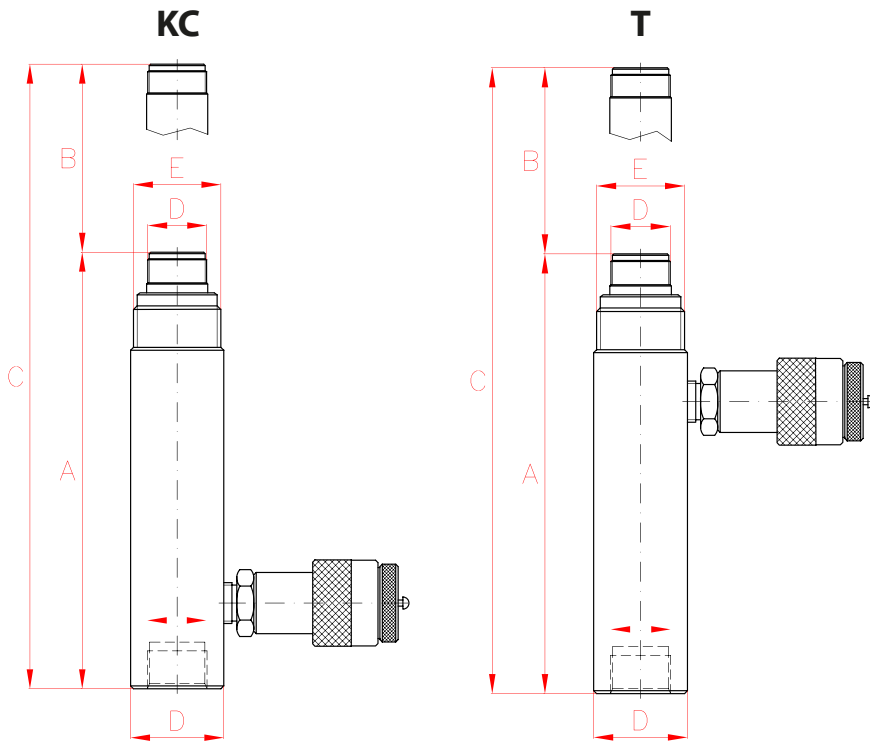

Available options	Model
Pulling cylinder*	T00514
Pressure gauge*	AV10006
Gauge adaptor*	AZ1502

**MAINTENANCE SET**



Type	<b>CA</b>
Capacity	10 Tn
Max. pressure	350 bar

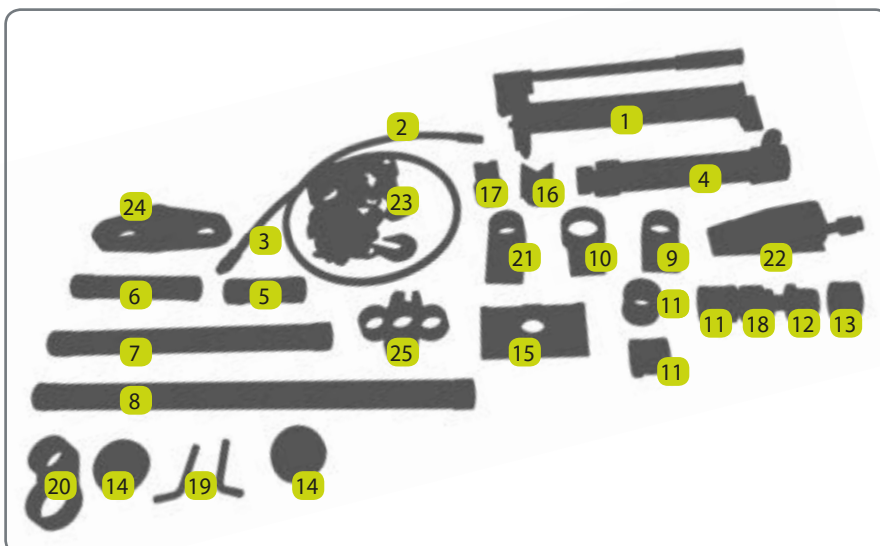

No.	Description	Quantity
<b>CA1014</b>		
1	Pump W10407	1
2	Hose	1
3	Male quick coupler	1
4	Cylinder KC01014	1
5	Tube M 130 mm	1
6	Tube L 230 mm	1
7	Tube X 480 mm	1
8	Tube XL 700 mm	1
9	Collar toe ram	1
10	Collar toe plunger	1
11	Pipe coupling	3
12	Male connector	1
13	Saddle	1
14	Rubber head	2
15	Base	1
16	"V" Base	1
17	Wedge head	1
18	Slip-lock extension	1
19	Locking pin	2
20	Collar clamp head	1
21	Lock-on clamp toe	1
22	Spread cylinder CY0108	1
23	Chain	1
24	Single chain plate	1
25	Double chain plate	1
	Case	1
	Weight (kg)	50



## APPLICATIONS AND SPECIAL PRODUCTS

With more than 75 years of experience in the hydraulic sector, LARZEP designs and manufactures high pressure hydraulic equipment for the movement of heavy loads, cylinders up to 2.000 Tn lifting capacity or split-flow systems for a more precise control of the load.

Our engineers are continuously developing special products and producing the drawings to build in a short time special

hydraulic tools that represent 30% of our sales. No matter if it's a one off, or a big batch.

All our cylinders are designed according to ANSI B30.1 / EN1494 and manufactured in our production facility located in Mallabia, in the North of Spain. Our biggest advantage against our competitors is our flexibility and quick delivery time.

*Contact our Sales Department to discuss your requirements, indicating type of product, quantity, capacity, stroke, or any another additional feature you may require.*

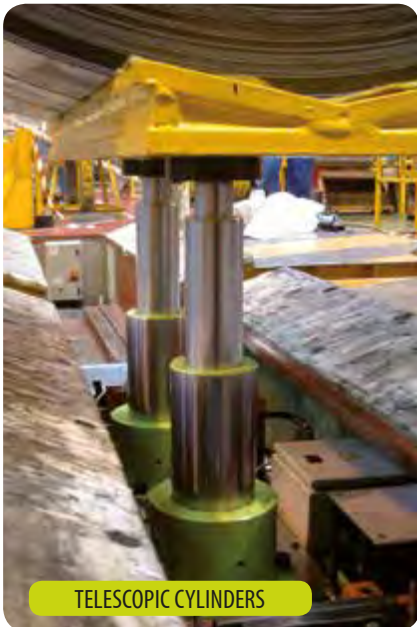

TELESCOPIC CYLINDERS



CYLINDERS AND PUMPS



HOLLOW CYLINDER AT CONSTRUCTION SITE



HIGH QUALITY GAUGES



# APPLICATIONS



## KIEV OLYMPIC STADIUM

Larzep manufactured the whole batch of double acting hollow bore cylinders for the construction of the new roof of the Olympic Stadium in Kiev. 108 cylinders of 220 Tn and 150 mm stroke and 60 cylinders of 120 Tn and 150 mm stroke were supplied. Over 30.000 tonnes of pulling capacity in total.

The cylinders were used to tension all the cables of the roof simultaneously.







### CATERPILLAR PIN PUSHER / CUSTOM MADE SOLUTION

The tool was used for the removal of caterpillars pins on Earth moving equipment. The pin was pushed through; in this case it took 251 metric tonnes to break the grip of the pin which was very badly worn.

A double acting cylinder, 350 ton and 300 mm stroke was used together with a 110 volt 2.1 litre per minute powerpack with remote control pendant for safety and ease of operation.

The system is strongly recommended by Health and Safety Authorities, as means of protection for the operators.



### CUSTOM MADE SOLUTIONS

Larzep designs and manufactures special cylinders and fixing systems, on customer request.

Do you have a special project and in need of a custom made hydraulic solution? Please contact our Internal Sales Department for further information.





# APPLICATIONS

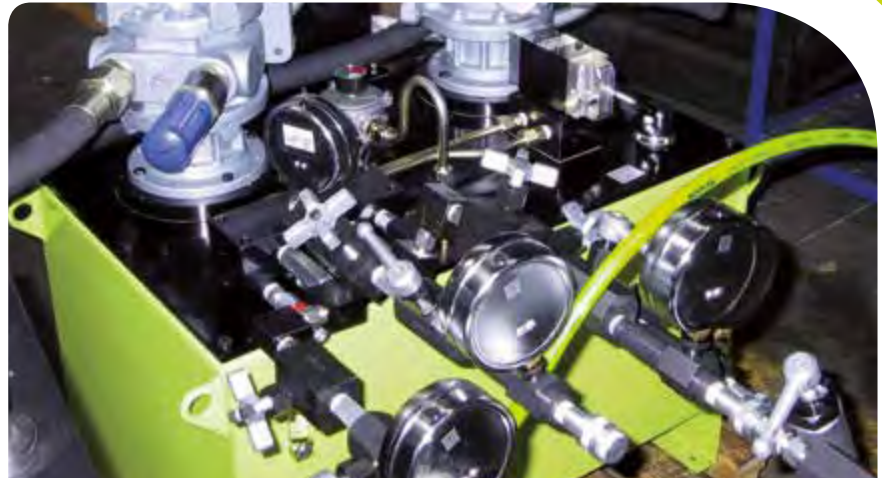

## OIL RIG RETRIEVAL

A hanger retrieval system developed with LARZEP products, for a major Oil & Gas operator in the North Sea.

The system consists of 4 Double acting 215 ton Hollow Bore Cylinders with 460 mm stroke, completely black nitrided to avoid rust in the North Sea environment and 2 pneumatic powered hydraulic pumps with safety double circuit each.



## LIFTING SYSTEM FOR MAINTENANCE

Larzep supplied seven 500 Tn lifting cylinders for the tub lift-and-split, twenty two 100 Tn cylinders along with an electric power pack incorporating valving controlled electronically via a PLC, all controlled by a laptop to work on the 6400 Tn Marion dragline.

The job was to remove the Marion 8750 Series B's tub, which weights 942 Tn for maintenance. This is understood to be a world-first for the mining industry. Two jacking frames, each with 1.000 Tn working load limit, were used for this procedure. Each jacking frame housed two 500 Tn Larzep cylinders.

Larzep lifting system contribute to successful maintenance lift on massive Queensland Dragline.





Hydraulic powerpack, 600 litre capacity with 3 different pumps to work at different pressures and flows.



Hydraulic powerpack, 600 litre capacity, with 4 pumps and 4 exits each. Each pump is connected to the 4 solenoid valves.



50 litres powerpacks with roll bar, wheels and heat exchanger.



10 litres Petrol powerpack with manual pump, 2 valves and by-pass.



Powerpack solenoid valve and by-pass, to work with 4 cylinders independently.



Petrol powerpacks for re-railing applications.

# SPECIAL PRODUCTS



Double acting cylinder with special saddle.



1.100 Tn single acting cylinder. With lock nut and base plate.



D/A cylinders with integrated AZ5700 pilot operated check valve.



Double acting cylinder with motorized lock nut and gear wheel.



1.000 Tn single acting cylinder with lock nut and tilting saddle. Supports a 12% side load.

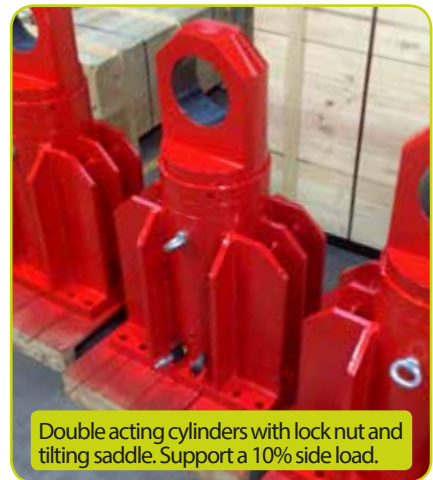

Double acting cylinders with lock nut and tilting saddle. Support a 10% side load.



500 Tn double acting cylinder with 1.250 mm stroke.

 Larzep designs and manufactures special cylinders and fixing systems. For further information, please contact our Internal Sales department.



**STEP BY STEP LIFTING**  
 Double acting cylinders  
 Available in steel or aluminium  
 Capacity: from 50 to 400 Tn  
 Stroke: 155 mm  
 Different plate dimensions  
 Optional tilting saddle



Double acting cylinders with tilting saddle and ceramic coating.





## SAFETY INSTRUCTIONS

When used correctly, hydraulic power is one of the safest methods of applying force to your work. To that end we offer some **DO's and DON'Ts**, simple common sense points which apply to practically all Larzep hydraulic products.

The illustrations and application photos of Larzep products throughout this catalogue are used to portray how some of our customers have used hydraulics in industry. In designing similar systems, care must be taken to select the proper components that provide safe operation and fit your needs.

Check to see if all safety measures have been adopted to avoid the risk of injury and property damage from your application or system. Larzep cannot be held responsible for damage or injury caused by unsafe use, maintenance or application of its products. Please contact the Larzep office or a representative for guidance when you are in doubt as to the proper safety precautions to be taken in designing and setting up your particular system.

In addition to these tips, every Larzep product comes with specific safety information and instructions. **Please read them carefully.**

### CYLINDERS

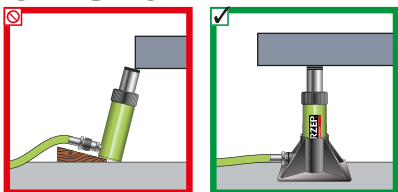

Provide a solid support for the entire cylinder base area. Use cylinder base attachment for more stability.

### CYLINDERS

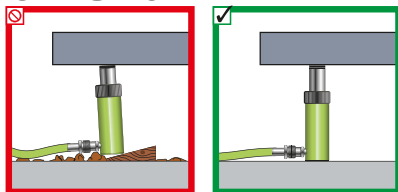

The entire cylinder saddle must be in contact with the load. Movement of the cylinder must be parallel with the movement of the load.

### CYLINDERS

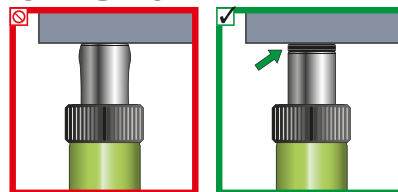

Do not use cylinder without saddle. This will cause plunger to "mushroom". Saddles distribute load evenly on the plunger.

### CYLINDERS

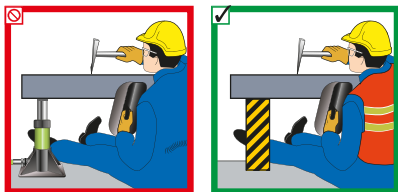

Never place any part of your body under the load. Load must be on cribbing before venturing under.

### CYLINDERS

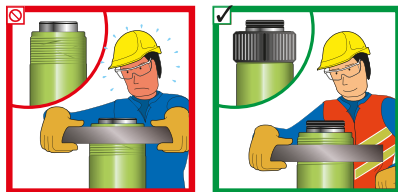

Always protect cylinder threads for use with attachments.

### CYLINDERS

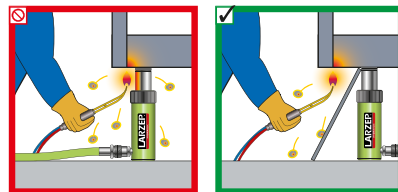

Keep hydraulic equipment away from open fire and temperatures above 65 °C.

### PUMPS

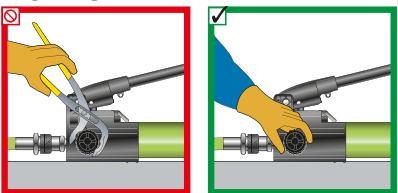

Close release valve hand tight. Using tools will ruin the valve.

### PUMPS

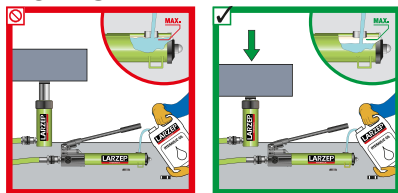

Fill pump only to recommended level. Fill only when connected cylinder is fully retracted.

### PUMPS

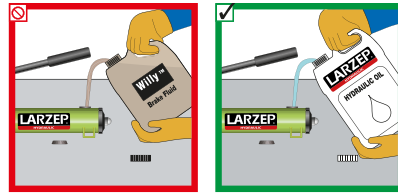

Always use genuine Larzep hydraulic oil.

### PUMPS

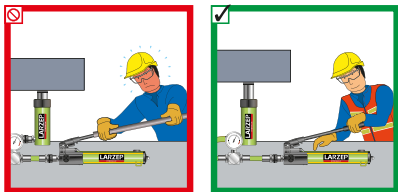

Don't use handle extenders. Hand pumps should be easy to operate when used correctly.

### JACKS

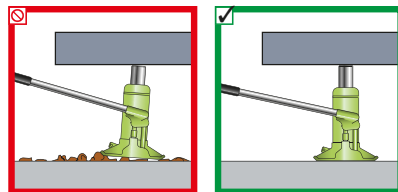

Provide a leveled and solid support for the entire jack base area.

### JACKS

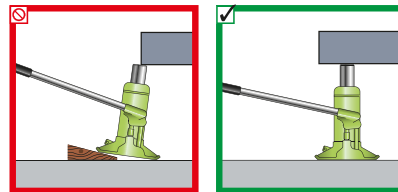

The entire jack saddle must be in contact with the load. Movement of the load must be in the same direction as jack plunger.

# SAFETY

For your application, choose the most suitable model from the wide range available, and make sure that it will **not exceed 80%** of its nominal capacity and stroke during normal operation.

The correct union of a pump to a cylinder via a hydraulic hose constitutes a machine designed for lifting, pulling, folding and retaining operations, etc., that, due to its high thrust capacity requires safe use in order to avoid accident risk.

Use protective goggles for eye protection. Use safety shoes for feet protection. Use protective gloves for hand protection.

Do not modify the device (welded parts, lengthening drive levers, etc.).

Do not use the hoses for transporting the device. Use the handles on the cylinders (when appropriate) and set the pump lever to the transport position.

When filling the pump with oil, use always LARZEP hydraulic oil. Fill only to the indicated level and remember that the cylinder piston should be retracted.

Before using a pump from other manufacturer, contact LARZEP's Technical Department. Otherwise, LARZEP will not be liable for any damage that may arise.

Before starting operation, check that the installation is correct, the operator position is safe and the working zone is out of bounds to all personnel.

In all cases, the operator should have received adequate training regarding the handling of the device and logical safety criteria associated with the movement of heavy loads.

Never exceed the maximum working pressure of the cylinder. Ensure that all the equipment and accessories are suitable for the maximum working pressure.



*Always read the safety instructions.*



### JACKS

Remove the jack handle when it is not being used.

### JACKS

Never place any part of your body under the load. Ensure the load is on a solid support before venturing under.

Always read instructions and safety warnings that come with your Larzep hydraulic equipment.

### HOSES AND COUPLERS

Clean both coupler parts before connecting. Use dust caps when coupler parts are not connected.

### HOSES AND COUPLERS

Keep hoses away from the area beneath loads.

### HOSES AND COUPLERS

Don't lift hydraulic equipment by the hoses.

### HOSES AND COUPLERS

Detach cylinder only when fully retracted or use shut-off valves or safety valves to lock cylinder pressure.

### HOSES AND COUPLERS

Don't kink hoses. Bending radius should be at least 80 mm. Don't drive over or drop heavy objects on hoses.

### HOSES AND COUPLERS

Never allow the cylinder to be lifted off of the ground through the couplers.



## CYLINDER SELECTION

In order to select the right cylinder according to your needs, please answer these questions:

- Total load to lift: \_\_\_\_\_ tonne / kg
- Number of cylinders required: \_\_\_\_\_
- Stroke required: \_\_\_\_\_ millimetres
- Closed height required: \_\_\_\_\_ millimetres
- Single or Double acting cylinder: \_\_\_\_\_
- Hollow or Solid piston: \_\_\_\_\_
- Spring or Load return: \_\_\_\_\_
- Push or Pull application: \_\_\_\_\_
- Lock nut is required? \_\_\_\_\_
- Tilting saddle is required? \_\_\_\_\_
- Threads, Attachments, are required? \_\_\_\_\_
- Special treatment is required? \_\_\_\_\_



**ATTENTION: DO NOT EXCEED THE 80% OF THE NOMINAL CAPACITY AND STROKE OF THE CYLINDER**



Taking into account all the above, we will show you all the different options you can use. To choose the Cylinder required, keep in mind the type of application.

Our internal sales department can advice, help you with the right choice of cylinders, specific to your project.

Visit our website [www.larzep.com](http://www.larzep.com) and find the applications of each type of cylinder.

# SELECTION TABLES

## PUMP SELECTION

In order to select the right pump according to your needs, please answer these questions:

### HAND PUMPS

Single or Double acting: \_\_\_\_\_

Number of cylinders required: \_\_\_\_\_

Cylinder capacity: \_\_\_\_\_ tonne

Cylinder stroke: \_\_\_\_\_ millimetres

Total hose length: \_\_\_\_\_ metres



### POWERPACKS

Single or Double acting: \_\_\_\_\_

Number of cylinders required: \_\_\_\_\_

Cylinder capacity: \_\_\_\_\_ tonne

Cylinder stroke: \_\_\_\_\_ millimetres

Total hose length: \_\_\_\_\_ metres

Manual or Solenoid valve: \_\_\_\_\_

Load holding is required? \_\_\_\_\_

Single or Three phase: \_\_\_\_\_

Voltage: \_\_\_\_\_ V

Frequency: \_\_\_\_\_ Hz

Remote pendant (for HBM) is required? \_\_\_\_\_

Roll bar, Wheel kit, Heat exchanger,  
Pedal or Pressure gauge are required? \_\_\_\_\_

1. Select the right cylinder, keeping in mind the recommended use of **80%** of its nominal rating of both, load and stroke.
2. Select the pump according to the oil volume and the number of cylinders in operation.

Use the table below as guideline. It is supposed the used of only one cylinder. For several cylinders, add oil capacities.

Capacity	Stroke (mm)												
	25	50	75	100	125	150	175	200	225	250	300	325	350
Tn													
5													
10													
15													
23													
30													
50													
75													
100													
140													
220													

- Single Acting W00307  
Double Acting X22307
- Single Acting W10707 - W20707  
Double Acting X22307
- Single Acting W11207 - W21207  
Double Acting X22307
- Single Acting W22307  
Double Acting X22307
- Single Acting W24307  
Double Acting X24307
- Single Acting W07807  
Double Acting X07807
- Single Acting HBM, HBE, HAG, HAZ  
Double Acting HBM, HBE, HAG, HAZ

**NOTE:** Add 35cc of oil per metre of hose used when the internal diameter of the hose is 6,4 mm.

Visit our website [www.larzep.com](http://www.larzep.com) for the online Cylinder or Pump Selection application.

## SINGLE ACTING ASSEMBLIES

- 1 Cylinder
- 2 Pump / Powerpack
- 3 Hose
- 4 Male Coupler
- 5 Pressure Gauge
- 6 Gauge Adaptor
- 7 Flow Regulating Valve
- 8 Check Valve
- 9 Female Coupler
- 10 Snubber Valve
- 11 Pilot Operated Check Valve
- 12 Tee
- 13 Split-Flow
- 14 Stroke Transducer
- \* Optional
- + Female coupler included in the cylinder

### BASIC SYSTEM SETUP



### COMPLETE SYSTEM



### COMPLETE SYSTEM WITH SEVERAL CYLINDERS

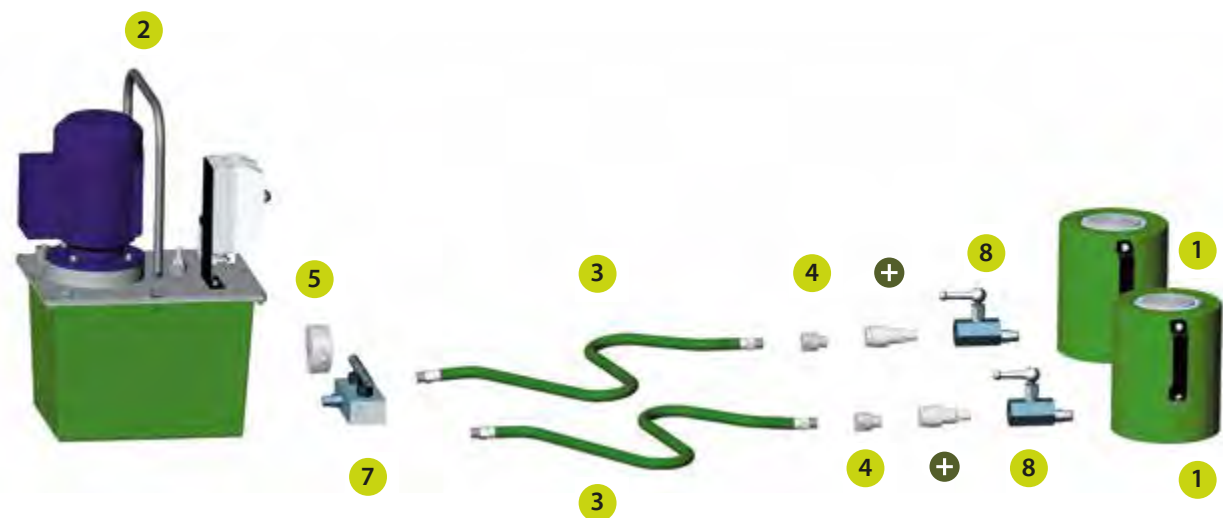

# SYSTEM ASSEMBLIES

## DOUBLE ACTING ASSEMBLIES

### BASIC SYSTEM

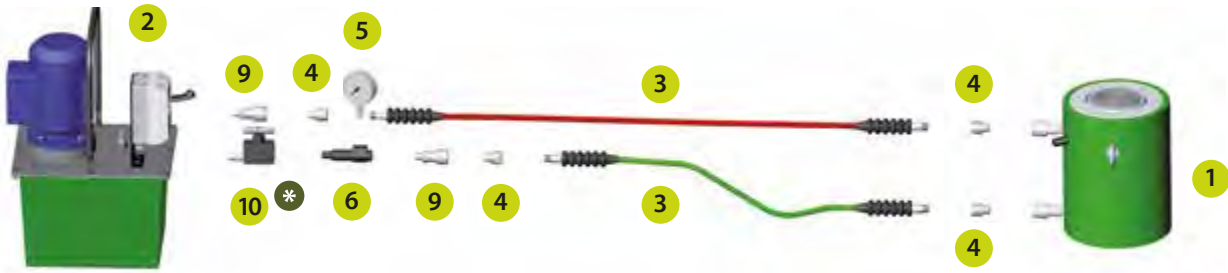

### COMPLETE SYSTEM WITH SEVERAL CYLINDERS

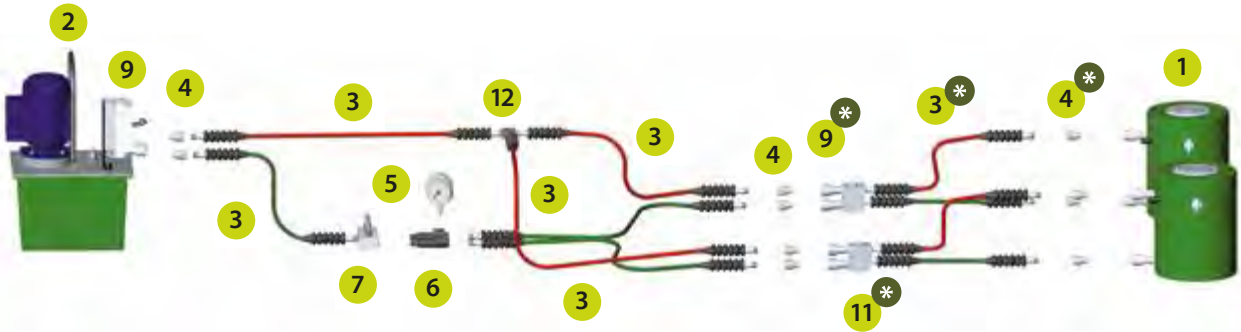

### COMPLETE SYSTEM WITH SPLIT-FLOW PUMP

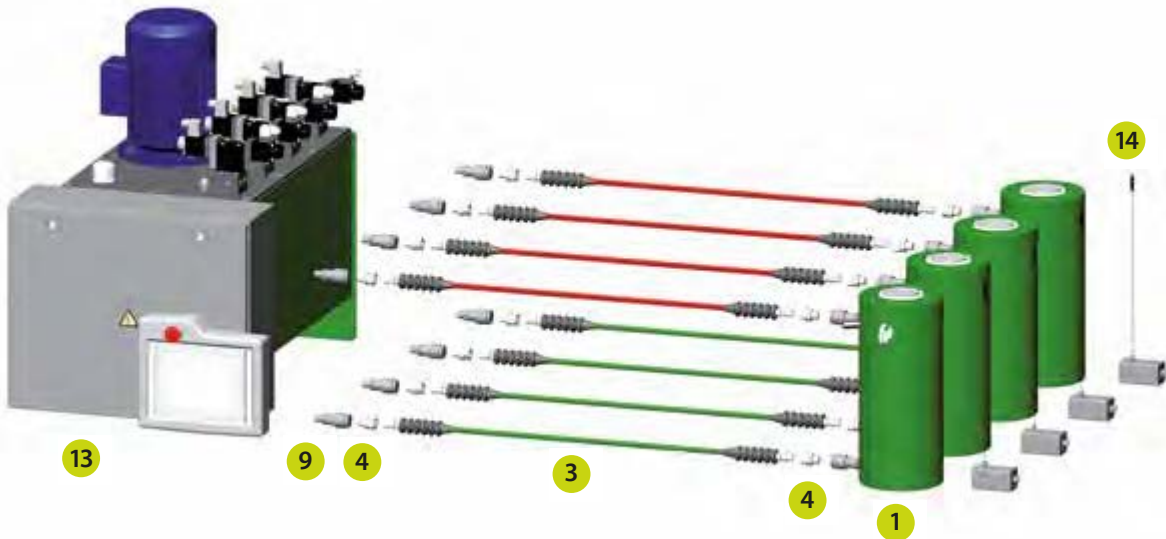

## VALVE INFORMATION

### CONTROL OF SINGLE ACTING CYLINDERS

Single acting cylinders require 3-way valve.

3-way valve has 3 ports: P pump, T tank and A cylinder.

3-way valve can have 2 or 3 positions.

**2 position valve** can only control the advance or the retraction of the cylinder.

**ADVANCE:** Oil flows from the pump P to the cylinder A. The cylinder will extend.

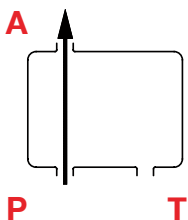

**RETRACT:** Oil flows from the cylinder A and pump P to the tank T. The cylinder will retract.

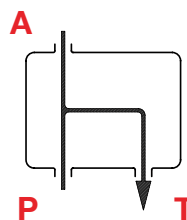

**3 position valve** controls advance, hold and retraction of the cylinder.

**ADVANCE:** Oil flows from the pump P to the cylinder A. The cylinder will extend.

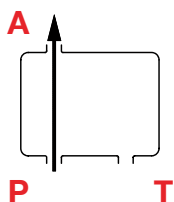

**HOLD:** Oil flows from the pump P to the tank T. A port is closed and holds the pressure maintaining the extended position.

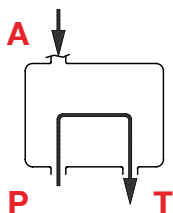

**RETRACT:** Oil flows from the cylinder A and pump P to the tank T. The cylinder will retract.

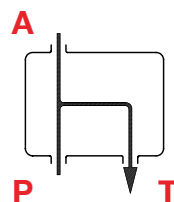

### CONTROL OF DOUBLE ACTING CYLINDERS

Double acting cylinders require 4-way valve.

4-way valve has 4 ports: P pressure, T tank, A advance and B retract.

4-way valve has 3 positions. 3 position valve can advance, hold and retract the cylinder.

**ADVANCE:** Oil flows from the pump P to the advance port A and from the return port B to the tank T. The cylinder will extend.

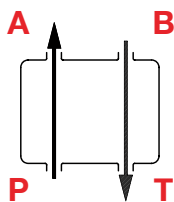

**HOLD:** Oil flows from the pump P to the tank T. A and B ports are closed and hold the pressure maintaining the extended position.

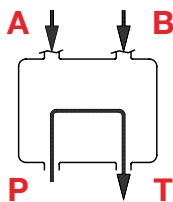

**RETRACT:** Oil flows from the pump P to the retract port B and from the advance port A to the tank T. The cylinder will retract.

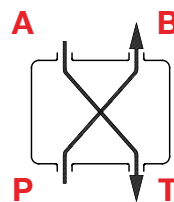



# TECHNICAL INFORMATION

## TORQUE TIGHTENING

The main function of the bolts and nuts is to create a clamping force across the joint which is able to sustain the operation conditions without loosening.

### TIGHTENING

The most used methods to tighten threaded fasteners are Torque, which is rotation of the nut or bolt head, or Direct Tension to stretch the fastener.

Hooke's Law states that the stress in a bolt is directly proportional to its strain, provided the applied force is kept within the materials elastic limits.

A fastener should be tightened until it has a retained tension of 40-60% of its elastic limit.

**Torque:** It is the turning or twisting force extended on a nut or bolt head. It is the product of two measurements: force and distance (N·m in the metric system).

The amount of torque to be applied to a threaded fastener depends on several factors: design application, type of joint, size, length and quantity of fasteners to be used and type of thread lubricant.

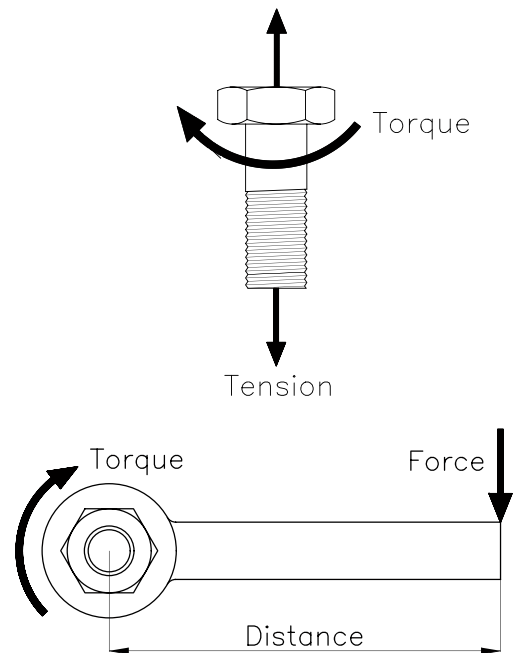

### WARNING

Loosening a nut or bolt usually requires more torque than tightening, mainly due to corrosion and deformation in the bolt and nut threads. Depending on conditions, breakout torque can take up to 2 ½ times the input torque.

**Direct tension:** It is applied to the fastener using a hydraulic tensioning device commonly known as a hydraulic stud bolt tensioner.

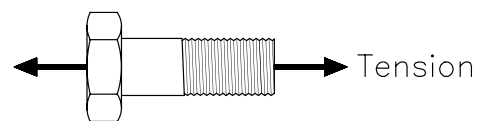

### TORQUE PATTERN

When all bolts cannot be tensioned or tightened simultaneously and only can tighten one bolt at a time, this can result in point loading and load scatter.

To avoid this, start tightening the bolts sequentially following the pattern shown, starting with a first pass at 25% of the final required torque, a second pass at 50% and a third pass at 100%.

Finally, perform a final check pass on each bolt working clockwise from bolt 1 at 100% of the required torque to ensure all bolts are uniformly tightened.

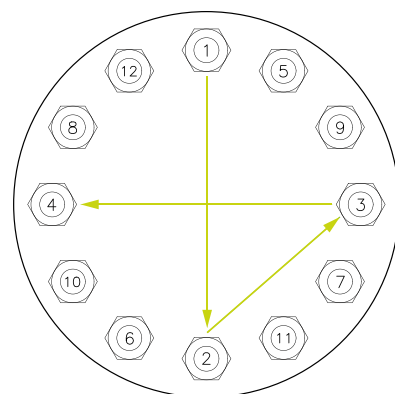

## BASIC HYDRAULICS

### PASCAL'S LAW

Pressure applied at any point upon a confined fluid is transmitted undiminished in all directions.

The hydraulic pressure at any point within the fluid is the same in all directions.

Hydraulic pressure is measured as a force per unit of area:

$$\text{kg / cm}^2 \approx \text{bar}$$

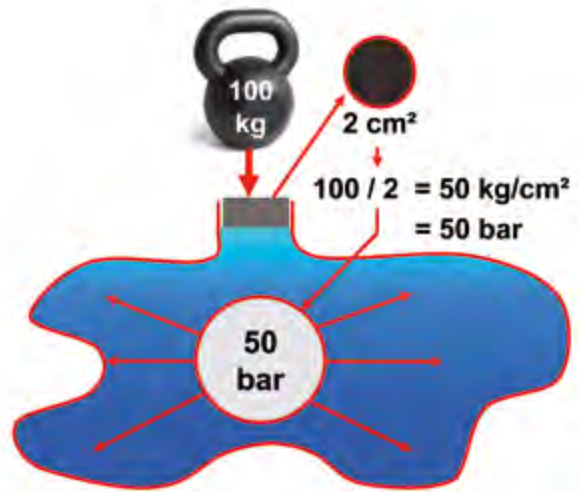

### FORCE

The force that a hydraulic cylinder can apply depends on the effective area of the cylinder and the hydraulic pressure.

Force (kg) = Hydraulic Pressure (bar) x Cylinder Effective Area (cm<sup>2</sup>)

$$F \text{ (kg)} = P \text{ (bar)} \times A \text{ (cm}^2\text{)}$$

### OIL CAPACITY

When a hydraulic cylinder is operated by a hand pump, the cylinder plunger moves a certain distance per pump actuation. This distance depends on the cylinder's effective area and on the pump's oil flow per stroke.

Minimum effective tank volume of pump is the sum of the oil volume of all cylinders and all hoses.

The volume of oil required for a cylinder is which need to achieve the full stroke of the cylinder.

Cylinder Oil Capacity (cm<sup>3</sup>) = Cylinder Effective Area (cm<sup>2</sup>) x Cylinder Stroke (cm)

$$V \text{ (cm}^3\text{)} = A \text{ (cm}^2\text{)} \times S \text{ (cm)}$$

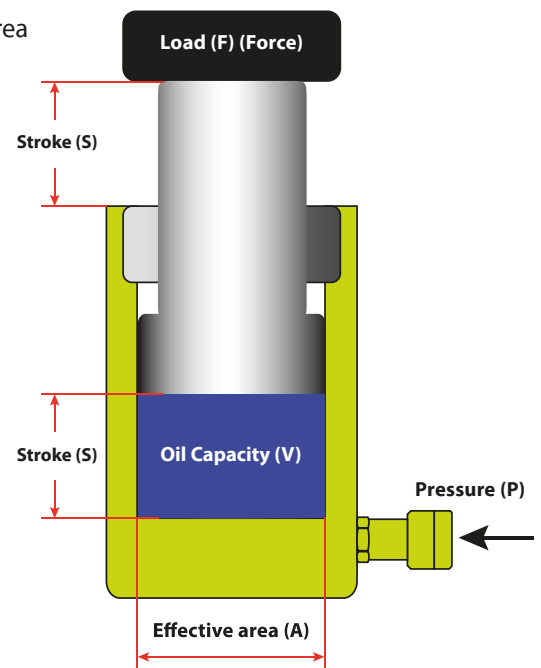

The oil flow always chooses the line of least resistance in a hydraulic system. When using more than one hydraulic cylinder, each cylinder lifts at its own speed. When the cylinders have the same capacity, it will start moving first the cylinder at the point of the lightest load and last the cylinder at the point of the heaviest load.

To make sure that the oil flow can be controlled to operate all the cylinders uniformly to lift the load horizontally, a control valve or a split-flow pump must be used.

### CYLINDER PISTON EXTENDING SPEED

$$\text{Piston Speed } v \text{ (mm/s)} = \frac{\text{Pump Oil Flow (cm}^3\text{/min)} \times 10}{\text{Cylinder Effective Area (cm}^2\text{)} \times 60}$$

# INFORMATION

## UNIT CONVERTER

LENGTH	
1 mm	= 0,039 in
1 cm	= 0,393 in
1 m	= 3,28 ft
1 in	= 25,4 mm
1 in	= 0,083 ft
1 ft	= 4 in
1 ft	= 0,305 m

MASS	
1 kg	= 2,205 lb
1 kg	= 35,27 oz
1 t	= 1000 kg
1 t	= 2205 lb
1 t	= 1,1 ton (short)
1 lb	= 0,453 kg
1 ton (short)	= 907,18 kg
1 ton (short)	= 0,907 t
1 ton (short)	= 2000 lb

FORCE	
1 kg	= 9,8 N
1 N	= 0,1019 kg
1 N	= 0,225 lb
1 kN	= 0,1019 t
1 kN	= 224,8 lb
1 lb	= 4,448 N

POWER	
1 kW	= 1.359 hp
1 hp	= 0,735 kW
1 w	= 1 J/s

AREA	
1 cm <sup>2</sup>	= 0,155 in <sup>2</sup>
1 m <sup>2</sup>	= 10,76 ft <sup>2</sup>
1 in <sup>2</sup>	= 6,45 cm <sup>2</sup>
1 in <sup>2</sup>	= 645 mm <sup>2</sup>

PRESSURE	
1 bar	= 0,1 MPa
1 bar	= 10 N/cm <sup>2</sup>
1 bar	= 1,0197 kg/cm <sup>2</sup>
1 bar	= 14.5 psi
1 Pa	= 1 N/m <sup>2</sup>
1 kPa	= 0,145 psi
1 MPa	= 10 bar
1 N/cm <sup>2</sup>	= 0,1 bar
1 kg/cm <sup>2</sup>	= 0,98 bar
1 psi	= 0,069 bar
1 psi	= 1 lb/in <sup>2</sup>

TORQUE	
1 kg·m	= 9,8 N·m
1 kg·m	= 86,79 lb·in
1 kg·m	= 7,233 lb·ft
1 N·m	= 0,1019 kg·m
1 N·m	= 8,85 lb·in
1 N·m	= 0,737 lb·ft
1 lb·ft	= 0,138 kg·m
1 lb·ft	= 1,356 N·m
1 lb·ft	= 12 lb·in
1 lb·in	= 0,0115 kg·m
1 lb·in	= 0,113 N·m

VOLUME	
1 cm <sup>3</sup>	= 0,061 in <sup>3</sup>
1 m <sup>3</sup>	= 1000 l
1 m <sup>3</sup>	= 1,3 yard <sup>3</sup>
1 ml	= 1 cm <sup>3</sup>
1 ml	= 0,035 oz-liq
1 l	= 1000 cm <sup>3</sup>
1 l	= 0,264 gal (US)
1 l	= 0,219 gal (UK)
1 l	= 61,023 in <sup>3</sup>
1 l	= 0,035 ft <sup>3</sup>
1 l	= 1,056 quart
1 in <sup>3</sup>	= 16,387 cm <sup>3</sup>
1 in <sup>3</sup>	= 0,016 l
1 in <sup>3</sup>	= 0,576 oz-liq
1 in <sup>3</sup>	= 0,017 quart
1 gal (UK)	= 4,546 l
1 gal (US)	= 3,785 l
1 gal (US)	= 3785 cm <sup>3</sup>
1 gal (US)	= 231 in <sup>3</sup>
1 gal (US)	= 0,133 ft <sup>3</sup>
1 quart	= 0,946 l

FLOW	
1 l/min	= 1000 cm <sup>3</sup> /min
1 l/min	= 0,264 gal/min (US)
1 l/min	= 0,22 gal/min (UK)
1 cm <sup>3</sup> /min	= 0,61 in <sup>3</sup> /min
1 in <sup>3</sup> /min	= 16,4 cm <sup>3</sup> /min
1 gal/min (US)	= 3,785 l/min

TEMPERATURE	
(°C x 1,8) + 32	= °F
(°F - 32) / 1,8	= °C

Visit our website [www.larzep.com](http://www.larzep.com) and use the Unit converter application.



Larzep, S.A. reserves all rights of total or partial modification of its models and features without prior notice.

**Larzep, S.A.**

Avenida Urriaga, 6 | 48269 Mallabia, Spain | Tel: (+34) 943 171200 | Fax: (+34) 943 174166 | E-mail: info@larzep.com

**Performance under Pressure**

**www.larzep.com**